



**ENGINEERING/OPERATIONAL COMMITTEE MEETING AGENDA
TRABUCO CANYON WATER DISTRICT
ADMINISTRATION FACILITY
32003 DOVE CANYON DRIVE, TRABUCO CANYON, CA
MAY 7, 2025 AT 8:00 AM**

COMMITTEE MEMBERS

Mark Anderson, Committee Chair
Glenn Acosta, Committee Member
John Horst, Committee Member Alternate

DISTRICT STAFF

Fernando Paludi, General Manager
Michael Perea, District Secretary
Lorrie Lausten, District Engineer
Gary Kessler, Water System Superintendent
Oscar Ulloa, Wastewater Superintendent
Jason Stroud, Maintenance Superintendent

AGENDA NOTE:

Trabuco Canyon Water District (District) will make this Engineering/Operational Committee Meeting available by telephone audio as follows:

Telephone Audio: 1 (669) 900-6833

Access Code: 973-7562-7682

Persons desiring to monitor the Committee meeting agenda items may download the agenda and documents on the internet at www.tcwd.ca.gov. You may submit public comments by email to the Committee at mperea@tcwd.ca.gov. In order to be part of the record, emailed comments on meeting agenda items must be received by the District at the referenced e-mail address not later than 7:00 a.m. (PDT) on the day of the meeting.

CALL MEETING TO ORDER

VISITOR PARTICIPATION

Members of the public wishing to address the Committee regarding a particular item on the agenda are requested to submit public comments by email to the Committee at mperea@tcwd.ca.gov. The Committee Chair will call on the visitor following the Committee's discussion about the matter. Committees do not constitute a quorum of the Board of Directors and Committee Members cannot make decisions on matters. The Committee makes recommendations only to the Board of Directors. Members of the public will be given the opportunity to speak to the Committee prior to making a recommendation on the matter. For persons desiring to make verbal comments and utilizing a translator to present their comments into English reasonable time accommodations, consistent with State law, shall be provided. Please limit comments to three minutes.

ORAL COMMUNICATION

Members of the public who wish to make comment on matters not appearing on the agenda are requested to submit oral communication by email to the Committee at mperea@tcwd.ca.gov. Under the requirements of State Law, Directors cannot take action on items not identified on the agenda and will not make decisions on such matters. The Board President may direct District Staff to follow up on issues as may be deemed appropriate. For persons desiring to make verbal comments and utilizing a translator to present their comments into English reasonable time accommodations, consistent with State law, shall be provided. Please limit comments to three minutes.

COMMITTEE MEMBER COMMENTS

REPORT FROM THE GENERAL MANAGER

ENGINEERING MATTERS

**PRESENTER(S): FERNANDO PALUDI, GENERAL MANAGER
MICHAEL PEREA, ASSISTANT GENERAL MANAGER
LORRIE LAUSTEN, DISTRICT ENGINEER**

ITEM 1: ENGINEERING/OPERATIONAL COMMITTEE MEETING RECAP

RECOMMENDED ACTION:

Approve the following Engineering/Operational Committee Meeting Recap(s) and recommend that the Board receive and file same (Consent Calendar).

1. April 2, 2025 Committee Meeting

ITEM 2: ADOPTION OF 2024 ORANGE COUNTY WATER AND WASTEWATER MULTI-JURISDICTIONAL HAZARD MITIGATION PLAN

RECOMMENDED ACTION:

Recommend that the Board of Directors adopt Resolution No. 2025-1345 approving the 2024 Orange County Water and Wastewater Multi-Jurisdictional Hazard Mitigation Plan (Action Calendar).

ITEM 3: APPROVAL AND ADOPTION OF UPDATED MEMORANDUM OF UNDERSTANDING (MOU) WITH ORANGE COUNTY SHERIFF'S DEPARTMENT FOR USE OF COUNTYWIDE MASS NOTIFICATION SYSTEM (ALERT OC)

RECOMMENDED ACTION:

Recommend that the Board of Directors approve the Memorandum of Understanding Between the County of Orange and Participants for Use of Countywide Mass Notification System and authorize the General Manager to execute the Public Mass Notification System Individual User Agreement (Action Calendar).

ITEM 4: WASTEWATER TREATMENT PLANT HEADWORKS REPLACEMENT PROJECT

RECOMMENDED ACTION:

Recommend the Board of Directors authorize the General Manager to purchase the Duperon FlexRake bar screen climber and compactor from JBI Water and Wastewater in the amount of \$334,000.

ITEM 5: DIMENSION WATER TREATMENT PLANT TRANSMISSION MAIN REHABILITATION

RECOMMENDED ACTION:

Receive information at the time of the meeting and take action(s) as deemed appropriate.

ITEM 6: PRELIMINARY 10-YEAR CAPITAL IMPROVEMENT PROGRAM

RECOMMENDED ACTION:

Receive information at the time of the meeting and take action(s) as deemed appropriate.



**TRABUCO CANYON WATER DISTRICT
ENGINEERING/OPERATIONAL COMMITTEE MEETING AGENDA | MAY 7, 2025**

ITEM 7: UPDATE ON STATE WATER BOARD CROSS CONNECTION CONTROL PLAN HANDBOOK (CCCPH) REQUIREMENTS AND CROSS-CONNECTION CONTROL MANAGEMENT PLAN (CCCMP) ADOPTION

RECOMMENDED ACTION:

Receive updated information at the time of the meeting and direct staff to take action(s).

ITEM 8: HARRIS GRADE TANK REPLACEMENT COST ESTIMATE UPDATE

RECOMMENDED ACTION:

Receive information at the time of the meeting and take action(s) as deemed appropriate.

ITEM 9: OTHER ENGINEERING AND OPERATIONS PROJECT UPDATES

1. Report on Completion of WWTP Handrail Replacement Project by District Personnel
2. Saddle Crest Development Update
3. District CMMS Asset Summary Update
4. Other Projects

RECOMMENDED ACTION:

Committee to receive project status updates at the time of the Committee Meeting.

OPERATIONAL MATTERS

PRESENTER(S): GARY KESSLER, WATER SYSTEM SUPERINTENDENT

OSCAR ULLOA, WASTEWATER OPERATIONS SUPERINTENDENT

JASON STROUD, MAINTENANCE DEPARTMENT SUPERINTENDENT

ITEM 10: WATER SYSTEM UPDATES

RECOMMENDED ACTION:

Committee to receive system status updates. No action required.

ITEM 11: WASTEWATER SYSTEM UPDATES

RECOMMENDED ACTION:

Committee to receive system status updates. No action required.

ITEM 12: MAINTENANCE DEPARTMENT UPDATES

RECOMMENDED ACTION:

Committee to receive system status updates. No action required.

REGULATORY AND OTHER MATTERS

ITEM 13: OTHER MATTERS/REPORTS

RECOMMENDED ACTION:

Hear Other Matters/Reports that may have arisen after the posting of the agenda.

ADJOURNMENT



**TRABUCO CANYON WATER DISTRICT
ENGINEERING/OPERATIONAL COMMITTEE MEETING AGENDA | MAY 7, 2025**

AVAILABILITY OF AGENDA MATERIALS

Agenda exhibits and other writings that are disclosable public records distributed to all or a majority of the members of the Trabuco Canyon Water District Board of Directors in connection with a matter subject to discussion or consideration at an open meeting of the Board of Directors are available for public inspection at the Trabuco Canyon Water District Administrative Facility, 32003 Dove Canyon Drive, Trabuco Canyon, California (District Administrative Facility) or will be posted online on the District's website located at www.tcwd.ca.gov. If such writings are distributed to members of the Board less than 72 hours prior to the meeting, they will be available online at www.tcwd.ca.gov at the same time as they are distributed to the Board Members, except that, if such writings are distributed immediately prior to or during the meeting, they will be posted online on the District's website located at www.tcwd.ca.gov.

COMPLIANCE WITH THE REQUIREMENTS OF CALIFORNIA GOVERNMENT CODE SECTION 54954.2

In compliance with California law and the Americans with Disabilities Act, if you need special disability-related modifications or accommodations, including auxiliary aids or services in order to participate in the meeting, or if you need the agenda provided in an alternative format, please contact the District Secretary at (949) 858-0277, at least 48 hours in advance of the scheduled Board meeting. Notification at least 48 hours prior to the meeting will assist the District in making reasonable arrangements to accommodate your request. The Board Meeting Room is wheelchair accessible.



**TRABUCO CANYON WATER DISTRICT
ENGINEERING/OPERATIONAL COMMITTEE MEETING | MAY 7, 2025**

ENGINEERING MATTERS

ITEM 1: ENGINEERING/OPERATIONAL COMMITTEE MEETING RECAP

RECOMMENDED ACTION:

Approve the following Engineering/Operational Committee Meeting Recap(s) and recommend that the Board receive and file same (Consent Calendar):

- 1. April 2, 2025 Committee Meeting*

CONTACTS (staff responsible): PALUDI/PEREA



TRABUCO CANYON WATER DISTRICT ENGINEERING/OPERATIONAL COMMITTEE MEETING RECAP | APRIL 2, 2025

DIRECTORS PRESENT

Mark Anderson, Committee Chair
Glenn Acosta, Committee Member

STAFF PRESENT

Fernando Paludi, General Manager
Michael Perea, Assistant General Manager
Lorrie Lausten, District Engineer
Gary Kessler, Water Superintendent
Jason Stroud, Maintenance Superintendent
Roseann Lejsek, Executive Assistant

STAFF ABSENT

Oscar Ulloa, Wastewater Superintendent

DISTRICT CONSULTANTS

None

PUBLIC PRESENT

None

CALL MEETING TO ORDER

Director Anderson called the April 2, 2025 Engineering/Operational Committee Meeting to order at 8:02 a.m.

VISITOR PARTICIPATION

No comments were received.

ORAL COMMUNICATION

No comments were received.

COMMITTEE MEMBER COMMENTS

None

REPORT FROM THE GENERAL MANAGER

None

ITEM 1: ENGINEERING/OPERATIONAL COMMITTEE MEETING RECAP

Mr. Paludi presented the Engineering/Operational Committee Meeting Recap for Committee review in accordance with the agenda.

RECOMMENDATION: The Committee recommended forwarding this matter to the Board of Directors (Consent Calendar).

ITEM 2: ROBINSON RANCH WASTEWATER TREATMENT PLANT BLOWER MODIFICATION PROJECT UPDATE

Mr. Paludi presented this matter for Committee consideration, and he reported that the project design includes the incorporation of sound panels and is nearing completion. Ms. Lausten provided a brief overview of the project, and she reported that sound panels are included in the design bid to mitigate the sound increase. Ms. Lausten added that the sound panels are broken out as an optional bid item and they could be added at a later time, if staff receives noise complaints. Ms. Lausten stated that the design bid will be ready to go out in two weeks, and that the project budget will be separated over two fiscal years. Ms. Lausten added that she anticipates construction to begin in Summer. A brief discussion occurred regarding the disposal of the old blowers.

RECOMMENDATION: None – Informational item only.

ITEM 3: RECYCLED WATER RESERVOIR DAM V-DITCH AND STORM DRAIN CULVERT REPAIR

Mr. Paludi presented this matter for Committee consideration. Ms. Lausten reported that a recent pipeline break at the Dove and Robinson Ranch Recycled Water Pump Stations (DCRRPS) damaged the V-ditch that originates at the base of Trabuco Dam and extends to a culvert structure underneath the lake access road near the William Lyon Pond spillway structure. Ms. Lausten stated the District is responsible for maintaining the V-ditch in order to keep water flowing into Dove Lake. Ms. Lausten added that this project is not in the original CIP budget, but because repair work on the V-Ditch is needed, and the culvert has also been in need of repair, it will be more cost-effective to replace the entire V-Ditch now. Ms. Lausten provided an overview of the bid responses, and she stated that staff recommends awarding the contract to JES Engineering. Mr. Stroud briefly reported on the challenges in working at the bottom of the V-ditch due to space constraints and that is another reason to replace the entire V-Ditch at this time.

RECOMMENDATION: Committee to recommend the Board of Directors award a construction contract for the Recycled Water Reservoir Dam V-Ditch and Culvert Repairs to JES Engineering in the amount of \$162,365.35, plus a 10% contingency of \$16,000, for a not to exceed amount of \$178,365.35.

ITEM 4: QUARTERLY CAPITAL IMPROVEMENT PLAN UPDATE

Mr. Paludi presented this matter for Committee consideration. Ms. Lausten presented the Capital Improvement Program (CIP) budget summary update for FY 2024-25. Ms. Lausten highlighted the projects that have been completed since the previous quarterly update in January 2025, along with various open projects and their current status. Ms. Lausten noted that adjustments are being made to ensure the District stays within the overall CIP budget.

RECOMMENDATION: None – Informational item only.

ITEM 5: OTHER ENGINEERING AND OPERATIONS PROJECT UPDATES

1. Update on 16" Transmission Pipeline Rehabilitation Project

Ms. Lausten provided a handout to the Committee outlining the multi-phase pipeline rehabilitation. Ms. Lausten provided an overview of the proposed replacement methods, and she stated that she will be meeting with contractors the following day to obtain a cost estimate for Phase 1a of the project. Ms. Lausten also stated that staff is working on a design to repair Filter #4 at the Dimension Water Treatment Plant (DWTP), and she stated that the design should be completed in three to four weeks. Discussion occurred regarding the pipeline rehabilitation options and the costs for repair.

**TRABUCO CANYON WATER DISTRICT
ENGINEERING/OPERATIONAL COMMITTEE MEETING RECAP | APRIL 2, 2025**

2. Orange County Public Works (OCPW) Trabuco Creek Bridge Project Update

Ms. Lausten provided an update on this matter, and she reported that she has plans to meet with County staff the following week to review the project and the potential to relocate the District’s pipeline. The Committee suggested that staff reach out to District Supervisor Don Wagner for assistance if needed.

3. Planet Bids; Online District Procurement Tool

Ms. Lausten provided an update on this matter, and she reported that Planet Bids is an online procurement tool that staff has deployed on the District’s website. Ms. Lausten stated that staff will have training the following week, and she stated that projects will be added to the site very soon. A brief discussion occurred regarding costs for the initial set up and subsequent years.

4. SCADA Project Update

Mr. Serpas provided an update on this matter, and he reported that upgrading to the communications system is in progress. Mr. Serpas stated that this phase of the project is expected to be completed by the end of FY 2025. Mr. Serpas also stated that staff is preparing an RFP for the SCADA Integrator On-Call Services to include fixing mobile applications, smaller control items, and on-call services for troubleshooting.

5. State Water Board Cross Connection Control Plan Handbook (CCCPH) Requirements & Plan Adoption Update

Mr. Perea provided an update on this matter, and he reported that staff will be bringing the final draft to the Committee next month for review and consideration. Mr. Perea provided the publication requirement timelines. Mr. Perea added that adoption of the CCCPH will simplify communication with customers regarding requirements and costs.

6. Other Projects

None

RECOMMENDATION: None – Informational item only.

ITEM 6: WATER SYSTEM UPDATES

Mr. Kessler reviewed the projects and repairs for the prior month, and he reported that Water Operations staff had completed the following tasks:

1. Worked with WM Lyles on SCADA cut over at the Ground Water Treatment Facility (GWTF).
2. Flushed 11 dead-end hydrants and blowoffs
3. Serviced 73 valves in Walden Homes, Trabuco Market Place and lower portion of Robinson Ranch.
4. Worked with Engineering to formulate a plan to repair/replace Main Transmission Line (MTL).
5. Replaced 8 drain valves on water filters at Dimension Water Treatment Plant (DWTP).

Mr. Kessler presented the Water System Summary for Committee review.

RECOMMENDATION: None – Informational item only.

ITEM 7: WASTEWATER SYSTEM UPDATES

On behalf of Mr. Ulloa, Mr. Perea reviewed the projects and repairs for the prior month, and he reported that Wastewater Operations staff had completed the following tasks:

1. Replaced 2” pipe train that feeds Recycle Water to Santa Margarita Water District (SMWD).

**TRABUCO CANYON WATER DISTRICT
ENGINEERING/OPERATIONAL COMMITTEE MEETING RECAP | APRIL 2, 2025**

2. Assisted in the cutover to the new SCADA system Barneburg / Golf Club / Bell Canyon / Heritage / Santiago Lift Station.
3. Assisted in the cutover to the refurbished SCADA system at the Robinson Ranch Wastewater Treatment Plant (WWTP).
4. Calibrate all flow meters at the WWTP.
5. Working through Cartegraph to organize and locate assets as they apply to Wastewater Operations.

Mr. Perea presented the Recycled Water System Summary for Committee review, and he reported that recycled water demand has decreased due to rainfall during the previous month. Mr. Perea also reported that Dove Lake is full, and he stated that the reservoir surface level was at 1,273 feet. Mr. Perea reported that Operations received sewer odor concerns in a community adjacent to the Santiago Canyon Estates, and he explained that there are private sewers situated below the District's gravity sewer. Mr. Perea added that staff is working with residents to educate them on how the system works and that the odor problems are associated with the private systems. Regardless, the District will increase the frequency of line cleaning to quarterly.

RECOMMENDATION: None – Informational item only.

ITEM 8: MAINTENANCE DEPARTMENT UPDATES

Mr. Stroud reviewed the projects and repairs for the prior month, and he reported that Maintenance staff completed the following tasks:

Projects and Repairs

Maintenance staff performed and/or completed the following tasks and projects:

Water Operations

1. Hydrotech at Booster one/Field office to add "run lights" to pump panels
2. Hydrotech at DWTP to continue booster III soft start replacement/programming

Wastewater Operations

1. Assisted waste ops at WWTP shut down for fiber optic cut-over
2. Assisted with Barneburg Lift Station cut over
3. Replaced battery at Barneburg Lift Station emergency gen
4. Hydrotech emergency callout to Golf Club lift for soft start replacement and new cable pull
5. Repair/grade access road behind WWTP
6. V-Ditch repair work with JES at Res One
7. Hydrotech at WWTP continuing electrical wire ID'ing at blower room

District Fleet Upgrades & Other Projects

1. Met with Verizon rep for field inspection on cellular phones
2. Replaced batteries with Vactor
3. Replaced batteries in Pete slide rail
4. WEROC inspection at Trabuco Creek debris flow

RECOMMENDATION: None – Informational item only.

ITEM 9: OTHER MATTERS/REPORTS

Mr. Serpas provided an update on the District's Computerized Maintenance Management System (CMMS) Cartegraph. Mr. Serpas provided a handout to the Committee of a high-level task status summary by department, and he reported that staff is currently working to add more historical data to the system.

**TRABUCO CANYON WATER DISTRICT
ENGINEERING/OPERATIONAL COMMITTEE MEETING RECAP | APRIL 2, 2025**

Mr. Perea noted that this asset data will assist with budget planning in future years. Discussion occurred regarding the data analysis abilities within Cartegraph. The Committee requested to see a summary breakdown by facility and requested that staff bring this report to a future Finance/Audit Committee meeting.

RECOMMENDATION: None

ADJOURNMENT

Director Anderson adjourned the April 2, 2025 Engineering/Operational Committee Meeting at 9:08 a.m.

DRAFT

**TRABUCO CANYON WATER DISTRICT
ENGINEERING/OPERATIONAL COMMITTEE MEETING | MAY 7, 2025**

ENGINEERING MATTERS

ITEM 2: ADOPTION OF 2024 ORANGE COUNTY WATER AND WASTEWATER MULTI-JURISDICTIONAL HAZARD MITIGATION PLAN

Trabuco Canyon Water District (TCWD or District) is a member of the Municipal Water District of Orange County (MWDOC) and benefits from participation with the Water Emergency Response Organization of Orange County (WEROC), which is a part of MWDOC. TCWD is required to adopt an updated Hazard Mitigation Plan (HMP) every five years to comply with regulatory requirements and statutes as described in this report; TCWD's prior HMP was adopted in 2019. The HMP is a strategic plan to assess and reduce the threats that their communities face from current and future hazard conditions, including, but not limited to:

- Climate Change
- Coastal Storms/Erosion
- Contamination
- Dam/Reservoir Failure
- Drought
- Earthquake Fault Rupture
- Flood
- Geologic Hazards – Expansive Soils
- Geologic Hazards – Land Subsidence
- High Winds/Santa Ana Winds
- Human-Cause Hazards – Terrorism
- Human-Caused Hazards – Hazardous Materials
- Landslide/Mudflow
- Power Outage
- Seismic Hazards – Ground Shaking
- Seismic Hazards – Liquefaction
- Tsunami
- Urban Fire
- Wildfire

Background on Hazard Mitigation

The Disaster Mitigation Act of 2000 amended the Robert T. Stafford Disaster Relief and Emergency Assistance Act (Stafford Act) to establish a framework for state, local, tribal, and territorial governments to engage in hazard mitigation planning as a prerequisite for receiving certain types of non-emergency disaster funding assistance. The requirements and procedures for implementing hazard mitigation planning provisions are outlined in Title 44, Chapter 1, Part 201 (44 CFR Part 201) of the Code of Federal Regulations. Since the passage of the Disaster Mitigation Act of 2000, additional legislation has further shaped hazard mitigation policy, including:

- The Sandy Recovery Improvement Act (SRIA) of 2013
- The Water Infrastructure Improvements for the Nation (WIIN) Act of 2016

To be eligible for certain federal grant programs, an approved and adopted Hazard Mitigation Plan is required. These grant programs include:

- Hazard Mitigation Grant Program (HMGP)
- Public Assistance Grant Program (PA)
- Building Resilient Infrastructure and Communities (BRIC)
- Safeguarding Tomorrow Revolving Loan Fund Program
- Fire Management Assistance Grant Program (FMAG)
- Rehabilitation of High Hazard Potential Dam Grant Program (HHPD)

2024 Orange County Water and Wastewater Multi-Jurisdiction Local Hazard Mitigation Plan (MJHMP) Update

In January 2024, WEROC initiated the update of the Orange County Water and Wastewater Multi-Jurisdiction Local Hazard Mitigation Plan (MJHMP) to ensure continued eligibility for Federal Emergency Management Agency (FEMA) hazard mitigation funding with the participation of Herndon Group – HSG (Consultant). District staff internally reviewed the Draft Administrative Report and Annex Jurisdictional Profile (Annex) specific to TCWD during late October and provided comments and edits to MWDOC/ WEROC and Herndon Group - HSG (Consultant) by the deadline of November 1, 2024. TCWD worked with WEROC submitted the MJHMP to the California Office of

**TRABUCO CANYON WATER DISTRICT
ENGINEERING/OPERATIONAL COMMITTEE MEETING | MAY 7, 2025**

Emergency Services (CalOES) on December 3, 2024, in accordance with the project milestones. The submission included all necessary documentation for compliance. CalOES completed its review on January 16, 2025, and provided revision requests for every agency annex. In response, WEROC collaborated with the project contractor to implement the required changes and resubmit the plan for final CalOES approval.

Ongoing Mitigation Planning

The Hazard Mitigation Plan is a living document that will evolve alongside the needs of participating agencies and communities. Agencies may identify new priorities or shift their goals based on emerging risks, updated data, or evolving circumstances.

To accommodate these changes:

- Adjustments will be documented throughout the plan implementation process.
- Formal plan updates will be conducted every five years, as required by FEMA.

By maintaining an active and adaptive approach to hazard mitigation planning, participating agencies can effectively reduce risks, enhance resilience, and ensure compliance with federal and state mitigation policies. More information may be presented at the time of the meeting.

FUNDING SOURCE:

General Fund

FISCAL IMPACT (PROJECT BUDGET)

Hazard Mitigation Plan Update(MJHMP)	\$	9,300
Risk & Resilience Assessment (RRA)	\$	32,200
Emergency Response Plan (ERP)	\$	17,250
Total Project Costs	\$	58,750

ENVIRONMENTAL COMPLIANCE:

Not applicable

RECOMMENDED ACTION:

Recommend that the Board of Directors adopt Resolution No. 2025-1345 approving the 2024 Orange County Water and Wastewater Multi-Jurisdictional Hazard Mitigation Plan (Action Calendar).

EXHIBIT(S):

1. [2024 Multi-Jurisdictional Hazard Mitigation Plan \(MJHMP\) - Trabuco Canyon Water District Annex Jurisdictional Profile](#)
2. Draft Resolution No. 2025-1345 – Resolution of the Board of Directors of the Trabuco Canyon Water District Adopting the Orange County Water and Wastewater Multi-Jurisdictional Hazard Mitigation Plan

CONTACTS (staff responsible): PALUDI/PEREA

RESOLUTION NO. 2025-1345
RESOLUTION OF THE BOARD OF DIRECTORS OF
THE TRABUCO CANYON WATER DISTRICT ADOPTING THE ORANGE COUNTY WATER
AND WASTEWATER MULTI-JURISDICTIONAL HAZARD MITIGATION PLAN

WHEREAS, the Trabuco Canyon Water District (TCWD or District) recognizes that the threat from natural hazards poses a risk to water and wastewater utilities and the individuals they serve, and impacts can result in regional economic and public health consequences; and

WHEREAS, TCWD is a member of the Municipal Water District of Orange County (MWDOC) and participates in choice-based funded programs through the Water Emergency Response Organization of Orange County (WERO); and

WHEREAS, MWDOC and 14 other member agencies, including TCWD, participated in the development of the Orange County Water and Wastewater Multi-Jurisdictional Hazard Mitigation Plan (MJHMP) in accordance with federal laws, including the Robert T. Stafford Disaster Relief and Emergency Assistance Act, as amended; the National Flood Insurance Act of 1968, as amended; and the National Dam Safety Program Act, as amended; and

WHEREAS, the Orange County Water and Wastewater MJHMP identifies mitigation goals and actions to reduce or eliminate long-term risk to people and property in Orange County from the impacts of future hazards and disasters; and

WHEREAS, a Planning Team was formed to participate in the FEMA-prescribed mitigation planning process to prepare the HMP; and

WHEREAS, a public outreach strategy to include whole community planning was implemented by including posting information on member agency websites, email and social media distribution, community survey, and presentations at the community meetings for inclusion and opportunity to participate in the planning process by community members, community-based organizations and people with access and functional needs; and

WHEREAS, on December 3, 2024, the MJHMP was provided to the California Office of Emergency Services (CalOES) Hazard Mitigation Division for review; and

WHEREAS, the MJHMP was revised based on CalOES requirements relating to the new Federal Hazard Mitigation Standards released in 2023 by the Federal Emergency Management Agency (FEMA); and

WHEREAS, TCWD with MWDOC and HSG (Consultant) made all required changes, and the plan was approved by CalOES and submittal to FEMA for review on February 14, 2025; and

WHEREAS, MWDOC has requested FEMA to grant approval pending adoption in the event there are any required changes, and subject to the member agencies adopting resolutions approving and adopting the MJHMP once FEMA review states all requirements are met; and

WHEREAS, adoption by the TCWD Board of Directors has reviewed the MJHMP and demonstrates its commitment to hazard mitigation and achieving the goals outlined in the Orange County Water and Wastewater Multi-Jurisdictional Hazard Mitigation Plan.

NOW, THEREFORE, BE IT RESOLVED by the TCWD Board of Directors that the ORANGE COUNTY WATER AND WASTEWATER MULTI-JURISDICTIONAL HAZARD MITIGATION PLAN (2025) is hereby adopted.

NOW, THEREFORE, BE IT FURTHER RESOLVED, while content related may require revisions to meet the plan approval requirements, changes occurring after adoption will not require TCWD to re-adopt any further iterations of the plan. Subsequent plan updates following the approval period for this plan will require separate adoption resolutions.

ADOPTED, SIGNED, AND APPROVED this 21st day of May 2025

TRABUCO CANYON WATER DISTRICT

By: _____
President/Vice President

By: _____
District Secretary

DRAFT

STATE OF CALIFORNIA)
) ss.
COUNTY OF ORANGE)

I, Michael Perea, District Secretary of the Trabuco Canyon Water District, do hereby certify that the foregoing resolution was duly adopted by the Board of said District at a regular meeting of such Board held on the 21st day of May 2025, of which meeting all of the members of the Board had due notice and at which a quorum thereof were present and acting throughout and for which notice and an agenda was prepared and posted as required by law and that at said meeting such resolution was adopted by the following vote:

AYES:

NOES:

ABSTAIN:

ABSENT:

District Secretary,
Trabuco Canyon Water District

STATE OF CALIFORNIA)
) ss.
COUNTY OF ORANGE)

I, Michael Perea, District Secretary of the Trabuco Canyon Water District, do hereby certify that the foregoing is a full, true, and correct copy of Resolution No. 2025-1341 of such Board and that the same has not been amended, rescinded, or repealed.

Dated this 21st day of May 2025.

District Secretary,
Trabuco Canyon Water District

**TRABUCO CANYON WATER DISTRICT
ENGINEERING/OPERATIONAL COMMITTEE MEETING | MAY 7, 2025**

ENGINEERING MATTERS

ITEM 3: APPROVAL AND ADOPTION OF UPDATED MEMORANDUM OF UNDERSTANDING (MOU) WITH ORANGE COUNTY SHERIFF'S DEPARTMENT FOR USE OF COUNTYWIDE MASS NOTIFICATION SYSTEM (ALERT OC)

In 2008, the County of Orange initiated a Countywide Mass Notification System called "AlertOC" for the purpose of contacting hundreds of thousands of Orange County residents in the event of an emergency. In 2013, this system was made available to other public agencies throughout the County, including Trabuco Canyon Water District (District), and the system has been used for a wide range of notifications, including severe weather warnings, COVID-19 notifications, and other emergencies.

At the June 19, 2013, Regular Board Meeting, the District's Board of Directors approved the Memorandum of Understanding (MOU) with the County to use the Countywide Mass Notification System under the terms and conditions of the system operating guidelines and vendor-provided agreements. The MOU has been regularly updated between the County of Orange (County) and participants, the previously approved MOU occurred in 2021. In late 2024, the County approved an updated MOU with a term of five years through December 30, 2029 with only minor changes, specific to system cybersecurity enhancements.

There is no cost to use the system at this time as the County is sponsoring this program. In partnership with the County of Orange, the Water Emergency Response Organization of Orange County (WEROC) serves as the Operational Area Water and Wastewater Mutual Aid Coordinator and facilitator of the execution on this agreement with all water and wastewater special districts that choose to use the system for the following reasons:

- Ensure training is provided on the system to the identified users
- Ensure training is provided on the coordination process contained in the AlertOC Policy/Standard Operating Procedure (SOP)
- Maintenance of universal templates for water and wastewater agencies in compliance with state and federal requirements on regulatory language

For the District to continue to participate and use AlertOC, the Board of Directors would need to approve the updated MOU with the County prior to May 31, 2025. District staff recommends the Board of Directors approve and authorize the General Manager to execute the updated MOU between the County of Orange and Participants for Use of the Countywide Mass Notification System.

FUNDING SOURCE:

General Fund

FISCAL IMPACT:

System Costs: The County sponsors the system and financial burden.

District Costs: None other than certain costs associated with staff time for training and data management of the system already approved in the FY 2024/2025 General Fund Budget – Salaries & Benefits.

ENVIRONMENTAL COMPLIANCE:

Not applicable

RECOMMENDED ACTION:

Recommend that the Board of Directors approve the Memorandum of Understanding Between the County of Orange and Participants for Use of Countywide Mass Notification System and authorize the General Manager to execute the Public Mass Notification System Individual User Agreement (Action Calendar).

**TRABUCO CANYON WATER DISTRICT
ENGINEERING/OPERATIONAL COMMITTEE MEETING | MAY 7, 2025**

EXHIBIT(S):

1. [Memorandum of Understanding Between the County of Orange and Participants for use of Countywide Mass Notification System](#)

CONTACTS (staff responsible): PALUDI/PEREA

**TRABUCO CANYON WATER DISTRICT
ENGINEERING/OPERATIONAL COMMITTEE MEETING | MAY 7, 2025**

ENGINEERING MATTERS

ITEM 4: WASTEWATER TREATMENT PLANT HEADWORKS REPLACEMENT PROJECT

The District operates the Robinson Ranch Wastewater Treatment Plant (RRWWTP) which treats up to 0.85 million gallons (MG) of sewage per day. This project will replace the existing headworks at RRWWTP. The headworks is the initial stage of the wastewater treatment process and removes large solids, grit and debris from the water before it enters the primary treatment system.

The current Parkson bar screen climber was installed in 1988 and has been in continuous operation four to six hours per day. Despite several repairs over the years, the system continues to experience recurring issues due to obsolete and hard-to-source parts. Staff often must salvage components from other equipment or modify existing parts, which is time-consuming and inefficient.

Staff originally budgeted \$130,000 in FY2025 to replace the existing system in-kind. However, after visiting other similar wastewater facilities and researching different improvement or replacement option, Staff has identified a more efficient and reliable alternative. The recommended Duperon FlexRake bar screen climber and compactor offers improved technology that is more durable, uses fewer breakable components, and provides better solids capture. As a result, the new system will not need to run as frequently, reducing both energy consumption and mechanical wear over time.

Staff recommends proceeding with the Duperon system and plans to complete the installation using in-house resources which could save as much as 50% of the overall cost of purchase and installation. A comparison of the evaluated systems is included as Exhibit 1. The District would purchase the Duperon system from JBI Water and Wastewater, which is the exclusive vendor of Duperon products. The detailed quote from Duperon/JBI for the FlexRake product is included as Exhibit 2.

FUNDING SOURCE:

Capital Improvement Program

FISCAL IMPACT (PROJECT BUDGET):

\$334,000 – FY 2025-26 CIP Budget (equipment only); staff costs for installation to be determined.

ENVIRONMENTAL COMPLIANCE:

Notice of Exemption

RECOMMENDED ACTION:

Recommend the Board of Directors authorize the General Manager to purchase the Duperon FlexRake bar screen climber and compactor from JBI Water and Wastewater in the amount of \$334,000.

EXHIBIT(S):

1. Photos and Product Comparison Information
2. Detailed Quote from Duperon/JBI Water and Wastewater

CONTACTS (staff responsible): LAUSTEN/ULLOA

Headworks New Equipment Replacement Project

Trabuco Canyon Water District

Engineering/Operational Committee meeting

May 7, 2025



Headworks Existing Bar Screen Climber Equipment



Rotating Drum Screen & Auger Equipment



Duperon Bar Screen Climber & Compactor Equipment



Types of Bar Screens for Wastewater

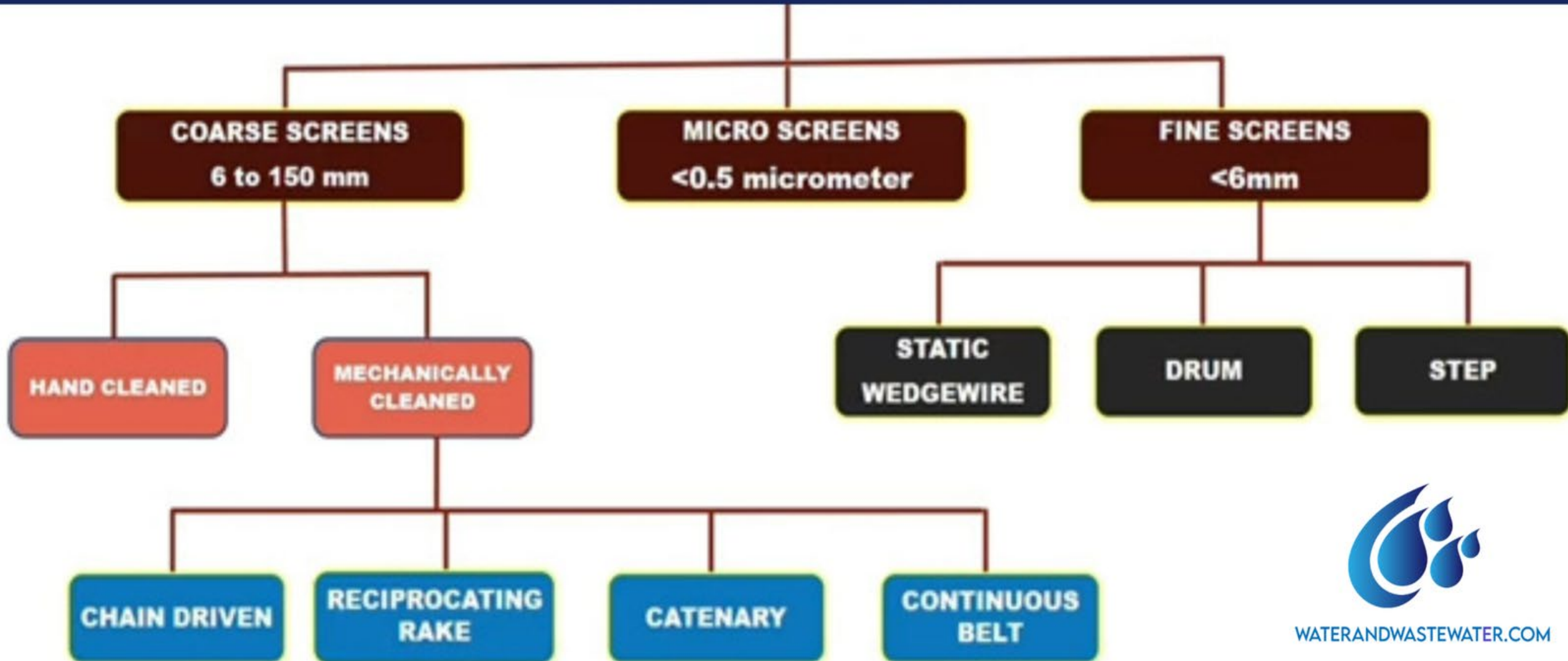

New Headworks Equipment Costs vs. Technology Comparison

	Vendor	Technology	SOW	Rehab. Costs	Equipment Costs	Turnkey Project Costs
1	Sancon	Coating Systems	Recoat existing interior of concrete headworks' comminutor box.	\$50,000		
2	Parkson	Bar Screen Climber	Overhaul existing Parkson Bar Screen Climber.	\$117,258		
3	Parkson	Rotating Drum Screen & Compactor	Replacement of existing Parkson bar screen climber & compactor with new rotating drum screen and compactor.		\$230,000	
4	Miscowater	Rotating Drum Screen & Compactor	Replacement of existing Parkson bar screen climber & compactor with new rotating drum screen and compactor.		\$134,695	\$169,940
5	Duperon	Bar Screen Climber & Compactor	Replacement of existing Parkson bar screen climber & compactor with new bar screen climber and compactor.		\$334,000	\$646,662
6	Duperon	Rotating Drum Screen & Compactor	Replacement of existing Parkson bar screen climber & compactor with new rotating drum screen and compactor.		\$228,298	\$597,212



DATE: April 18, 2025

Mechanically Cleaned Bar Screen
Firm Proposal Number P13947 R4
FlexRake® FR IQ
Robinson Ranch WWTP Trabuco Canyon, CA

To:
David Rodriguez
Trabuco Canyon Water District
(949) 550-4194
drodiguez@tcwd.ca.gov

Sales Representative:
Jonathan Sanchez
JBI Water & Wastewater Equipment
(949) 235-1860
Jonathansanchez@jbiwater.com

From:
Alex Peruski
Sales Project Manager
Duperon Corporation
(989) 754-8800
aperuski@duperon.com

Lorene Bruns
National Sales Manager
Duperon Corporation
(989) 239-6856
lbruns@duperon.com



Thank you for considering Duperon® system solutions for your project. We appreciate the opportunity to provide you with a Budgetary Equipment Scope. Please do not hesitate to contact your Duperon® Team with any questions as we work with you through the design process and ensure a successful project.

Scope of Supply:

(1) Mechanical Bar Screen - Stainless Steel Link Driven, Front Cleaning, Front Return

- **Model FlexRake®**
 - **FR IQ – Outdoor Installation**
- Continuous Cleaning without an operator
- Head Sprocket Only Design – no critical components under water
- Continuous Cleaning, top to bottom, the entire width of scraper
- SSSL2205 Scrapers designed to handle rocks, stones and heavy grit
- SSSL304 side fabrications, dead plate and cross members
- SSSL304 full enclosure covering from deck to discharge
- SSSL304 enclosure access panels
- SSSL304 FlexLinks
- SSSL316 Nameplate
- 1 HP Motor
- SSSL304 Drive Head:
 - Drive Sprockets and components SSSL304
 - Drive Shaft SSSL304

Dimensions and design criteria

- 1.50 ft channel width
- 3.17 ft channel height
- 5.17 ft channel invert to top of operating deck
- 3.5 ft discharge clearance into washer compactor
- 12 ft nominal length of FlexLink and scraper system
- 0.25 inch clear opening
- 0.25 inch x 0.75 inch x 0.13 inch SSSL316L tear drop bar screen
- 5.0 ft screen field length
- 30 degree from vertical
- 1 ft of head differential structural design

Hydraulic Profile

- See attached models for hydraulic performance information.
 - Peak Flow = 1.10 MGD with designated 1.00 ft minimum downstream water level @ 25% blinding factor
 - Average Flow = .60 MGD with 1.00 ft minimum downstream water level @ 25% blinding factor

Estimated Anchors Needed for Mechanical Bar Screen:

Estimated Anchors Needed **(not included in scope of supply –by Others/Contractor):**

- 304 SSSL Anchors
 - Anchors for toes and plates
 - 12 mm (1/2 inch) diameter x 115 mm (4-1/2 inch) long Embed HILTI KWIK bolt TZ
 - Minimum concrete depth of 6-3/4 inches
 - Anchors for Return Guide / Closeout, per screen
 - 9.5 mm (3/8 inch) diameter x 85 mm (3-3/8) inch long Embed HILTI KWIK bolt TZ
 - Minimum concrete depth of 5-1/16 inches
- Some minor field welding will be required at the top of the channel support bar and at the operating deck anchor points



(1) Duperon® Washer Compactor - Dual Auger Unit

- **Model WC3.D1.5.0.11**
 - 1HP Motor and gearbox
 - 2.31 ft from operating deck to top of washer compactor
 - 5.80 ft unit length
 - 1.29 ft unit width
 - SSTL316 Nameplate
 - SSTL304
- **Reduced Maintenance**
 - Accepts variable debris up to four inches, including rocks, clothing, concrete, metal, grease and septage – eliminating jams and equipment shutdown
 - SSTL304 inlet hopper designed to align with bar screen discharge
 - Positive displacement technology assures that all debris which enters the hopper is washed, compacted, and discharged for disposal
 - Durable dual auger design eliminates debris wrapping
 - Non-clogging flood wash port located prior to compaction housing – ideal for non-potable water
- **Reduced Odor**
 - Up to 60% dry solids and up to 60% mass/weight reduction – significantly reducing fecal content and odor
- **Reduced Landfill Costs**
 - Up to 84% volume reduction
 - Self-Regulating Compaction Housing – allows for consistent dry solids output regardless of fluctuations in debris volume
- **Reduced Power Consumption**
 - 1 HP inverter duty motor consumes just 746 watts
 - Requires .75 KWH

Discharge chute design

- Up to 10.00 ft long discharge chute with required bends and supports

Water supply and drain criteria

- Non-Clog Flood Washing
- Utilizes filtered effluent or municipal water
- Consumes 3 to 10 gallons per minute at 40 to 60 PSI
- 3.00 inch NPT male drain connection
- 0.50 inch NPT water supply connection
- Ball valves and WYE strainer to be provided by others.
- Solenoid valve supplied by Duperon (shipped loose).

Estimated Anchors Needed for Washer Compactor:

Anchors Needed (not included in scope of supply –by Others/Contractor):

- 304SSTL Anchors
 - Anchors for toes and plates
 - 12 mm (1/2 inch) diameter x 115 mm (4-1/2 inch) long Embed HAS Rods w/ Hilti RE-500-V3 Adhesive System
 - Minimum concrete depth of 6-3/4 inches

Washer Compactor Spare Parts

- (2) Upper/Lower Support: Auger
- (2) Side Support: Auger
- (24) FHCS: 0.25-20x1
- (24) 0.25 Flat Washer SAE
- (24) 0.25 Nylock Nut
- (1) Anti-Seize Lubricant
- (1) 14 oz. grease tube



(1) Controls Package, Main Panel

- **NOTE: Per NFPA 820, the main control panel shall not be in an NFPA-classified area.**
- Main fusible disconnect for incoming power 480V/60Hz/3Ph
- Wall mount NEMA 4X SSSL304 enclosure
- Enclosure to be:
 - Located indoors (outdoors) in an unclassified area
 - Not located where temperatures drop below 0°C (32°F) frequently
 - Not located where temperatures exceed 40°C (105°F) frequently
- Enclosure to include equipment
 - (1) FlexRake with 1.0 HP motor driven by AB PowerFlex 525 VFD with panel mounted keypad and line reactor
 - (1) Washer Compactor with 1.0 HP motor driven by AB PowerFlex 525 VFD with panel mounted keypad and line reactor
- Relay Based control, to include
 - Pilot lights, push buttons and selector switches on front door
 - Terminal blocks, ETM's, breakers, and relays where required
 - Hand-Off-Auto selector switch uses PB station in Hand mode
 - Hard contact SCADA Interlock(s) Run, No Fault, Auto, Remote start
 - Adjustable on/off cycle timers
 - Machine runs when remote start contact is made or run timer is active, it doesn't speed up unless a float is selected
- Enclosure environmental controls and accessories
 - Heater, fan, thermostat and rain hoods for fan assembly
 - Sun visors for VFD panel door interfaces
- Instrumentation
 - Dual Float Level Control
 - (2) Mechanical Float Switch including 50 ft long cabling.
- Local to equipment mounted devices
 - (1) Three hole NEMA 4X/7/9 enclosure with E-Stop maintained contact pushbutton, Jog-Reverse pushbutton, and Forward pushbutton

Bar Screen Spare Parts

- (10) Snap Rings
- (2) Link Clevis Pins
- (4) Button Head Cap Screw
- (4) 3/8"-16 Nylock Nut
- (1) Snap Ring Tool
- (1) 1 oz. Anti-Seize Lubricant

Washer Compactor Spare Parts

- (2) Upper/Lower Support: Auger
- (2) Side Support: Auger
- (24) FHCS: 0.25-20x1
- (24) 0.25 Flat Washer SAE
- (24) 0.25 Nylock Nut
- (1) Anti-Seize Lubricant
- (1) 14 oz. grease tube

On Site Technical Assistance for Installation Certification, Start-Up, and Training

- (1) Trip(s)
 - (1) Technician
 - (2) 8 hour man-day(s) total onsite
- If additional Technical Service days are required, please add per the rates included in the Clarifications section of this scope of supply.*

Warranty

- One Year Standard material and workmanship
- Five year warranty on all rotating parts (**FlexRake only**)

Freight to Jobsite



Price is valid for 30 days.

Submittals: 6-8 weeks after approved purchase order, based on workload

Equipment Ship: 18-26 weeks after approval to release manufacturing, based on workload

Clarifications:

General Clarifications

- Scope of supply and pricing above does not include additional structure for seismic, additional head differential or wind conditions
- See Duperon Contractor Installation Guides for guidance in estimating these costs.
- Duperon requires 3 week's advanced notice in writing to schedule field service technician on site.
- Field Services will be provided as outlined in this proposal. Duperon field service rate is \$1200 per day plus travel and per diem expenses. If field service personnel arrive on site as scheduled and the project is not ready for intended services to be performed, Duperon will invoice for additional days, if required. If the time required is greater than the time listed in this proposal, Duperon will invoice at the above rates.
- The specifications listed are the only specifications which shall apply to this proposal either directly or by reference. Any additional specifications, with equipment or requirements specified therein, that are not specifically included as part of this offer are excluded from this proposal.
- All anchor bolts require a minimum concrete depth of 1.5 times the embedment

Bar Screen Clarifications

- The bar screen will be shipped fully assembled
- It is recommended on sites with solid plate/grating across channels; that channel ventilation connection points occur upstream of mechanical screening equipment as necessary to relieve the channel fumes from exhausting only through the equipment enclosure
- Field assembly of SSTL screen enclosure required.
- Some minor field welding will be required at the top of the channel support bar and at the operating deck anchor points.
- Crane may be required for unloading.
- Spreader bar may be required for unloading
- Scope of supply and pricing above does not include additional structure for seismic, additional head differential or wind conditions.
- Modifications to the existing channel will be required and shall be competed by others

Washer Compactor Clarifications

- Some minor field assembly required
- Water supply and discharge piping by others
- Mounting hardware by others
- Ball valves and WYE strainer to be provided by others
- Compactor chute currently limited to 10 ft – additional chute length can be provided for additional cost

Controls Clarifications

- All conduit and field wiring between the equipment by others
- Mounting hardware by others
- Site Power supply to be verified

Not Included:

- Anything not specifically stated in this Proposal.
- Bonding, all tariffs (import and export), permits, taxes, liquidated damages.
- Construction and /or installation work of any kind at the jobsite.
- On-site conditions affecting the work described or which affects the installation.
- Conduit, stands, control mounting wiring, junction boxes, or other accessories.



- Any site work or installation tasks (ie, unloading, placement, dewatering, diving, clearing the forebay, wiring, provision of concrete structure, etc.), equipment (such as cranes, hammer drills, etc.), or anchors.
- Pre-installation tasks such as touch-up painting, checking bolts for tightness, removal of shipping containment devices, etc.
- Engineering: Does not include drawings other than those for the FlexRake, Tank and Compactor
- Additional structure for seismic or wind conditions.
- Offloading or handling of delivered equipment.
- Union labor for all field support services.
- Controls not specifically listed above.
- Videotaping of the training sessions
- Release of proprietary information.
- Insulation or weather proofing.
- Site/field painting or touch up.
- Vibration and noise testing.
- Anchors by others.
- Discharge system.
- Stilling wells.

Payment Terms:

- 5% Due with placement of order
- 20% Invoiced upon submittal of engineering drawings
- 70% Invoiced at time of shipment
- 5% Invoiced upon execution of startup services or 60 days after shipment, whichever is less.
- All payments are due Net 30 days
- Based upon review and approval by Duperon credit department.
- No retentions allowed.

Proposal Terms:

- This offer is subject to the enclosed Duperon Corporation Terms and Conditions page unless alternate terms and conditions are specifically negotiated in writing and are signed/accepted by Duperon Corporation at the time of purchase.
- May be subject to material price escalation.
- This proposal is based upon the information available at this time and may be impacted by future specifications, scope, and other requirements.
- Duperon Corporation retains the right to revise, withdraw, or negotiate this offer at any time prior to signing a material contract.

Order Processing:

To facilitate timely order processing and submittals, refer to this proposal number and please list purchaser contact, telephone, fax, and email with your purchase order. Please provide with your order a copy of trade references and, if tax exempt, please provide a resale or tax exemption certificate. Purchase Order should be sent to and payment remitted to:



Firm Proposal
Proposal Number
P13947 R4

Trabuco Canyon, CA

Duperon Corporation
1200 Leon Scott Court
Saginaw, MI 48601
Ph. 800-383-8479
Fax 989-754-2175

Approved for Purchase by:

Signature

Date

Printed Name

Phone Number

Title

Company Name & Address

Purchase Total



NOTE #1

VERIFY THAT THE PROPOSED INSTALLATION IS SUITED TO THE SITE.

- a. VERIFY CHANNEL WIDTH DIMENSION.
- b. VERIFY MOTOR LOCATION.
- c. VERIFY CHANNEL HEIGHT.
- d. VERIFY CHANNEL LENGTH. (2) PLACES
- e. NOT USED.
- f. VERIFY DOWNSTREAM WATER LEVEL @ PEAK FLOW.
- g. VERIFY DEBRIS BIN HEIGHT AND LOCATIONS. (4) PLACES

NOTE #2

- 1. BARSCREEN AND SCRAPERS NOT SHOWN FOR CLARITY.
- 2. SITE DIMENSIONS ARE SUBJECT TO CHANGE UPON SITE VERIFICATIONS.
- 3. FRONT AND REAR ENCLOSURE INCLUDED ABOVE OPERATING DECK. STAINLESS STEEL SIDE SHIELDS ARE INCLUDED FROM TOP OF CHANNEL TO OPERATING DECK TO PREVENT DEBRIS CARRYOVER.
- 4. DECK SUPPORT ACCESSORIES ARE AVAILABLE TO SPAN CHANNEL FOR SUPPORT/ANCHORAGE IF NO CONCRETE DECK IS AVAILABLE.
- 5. PLATE/GRATING AND HANDRAIL MODIFICATIONS AS REQUIRED (BY OTHERS).
- 6. FOR SITES W/ FREEZING CONDITIONS A DEAD PLATE HEAT PAD AND WC HEAT TRACE/WRAP ACCESSORIES ARE RECOMMENDED. NOT INCLUDED AT THIS TIME.
- 7. WASHER COMPACTOR CHUTE ROUTING SHOWN IS CONCEPTUAL. CHUTE ROUTING AND SUPPORT DETAILS (NOT SHOWN) WILL CHANGE BASED ON FINAL DESIGN AT TIME OF SUBMITTALS. FLOOR STAND SUPPORTS SHALL BE PROVIDED, AS REQUIRED, BY DUPERON. CEILING HANGER SUPPORTS SHALL BE SUPPLIED, AS REQUIRED, BY OTHERS.

REVISIONS				
REV.	DESCRIPTION	DATE	REVISED	APPROVED

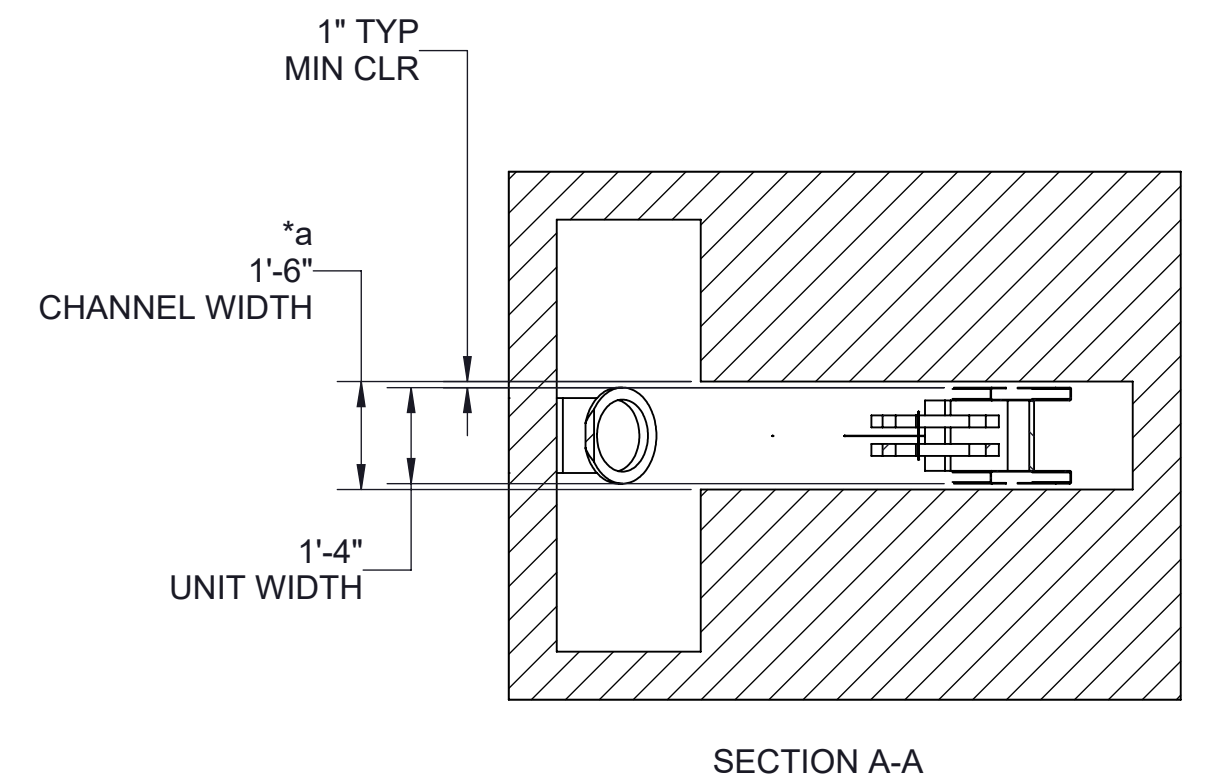
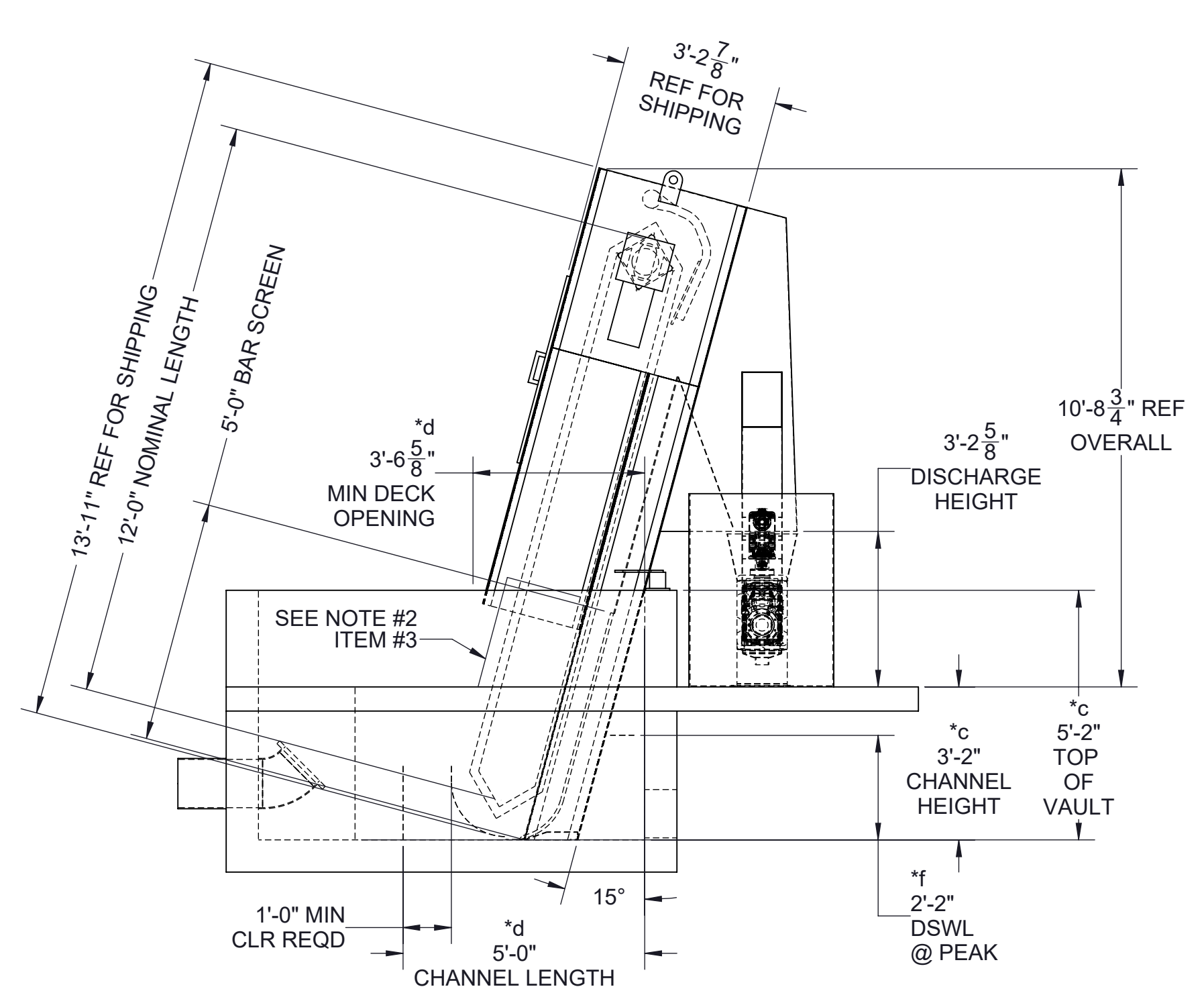
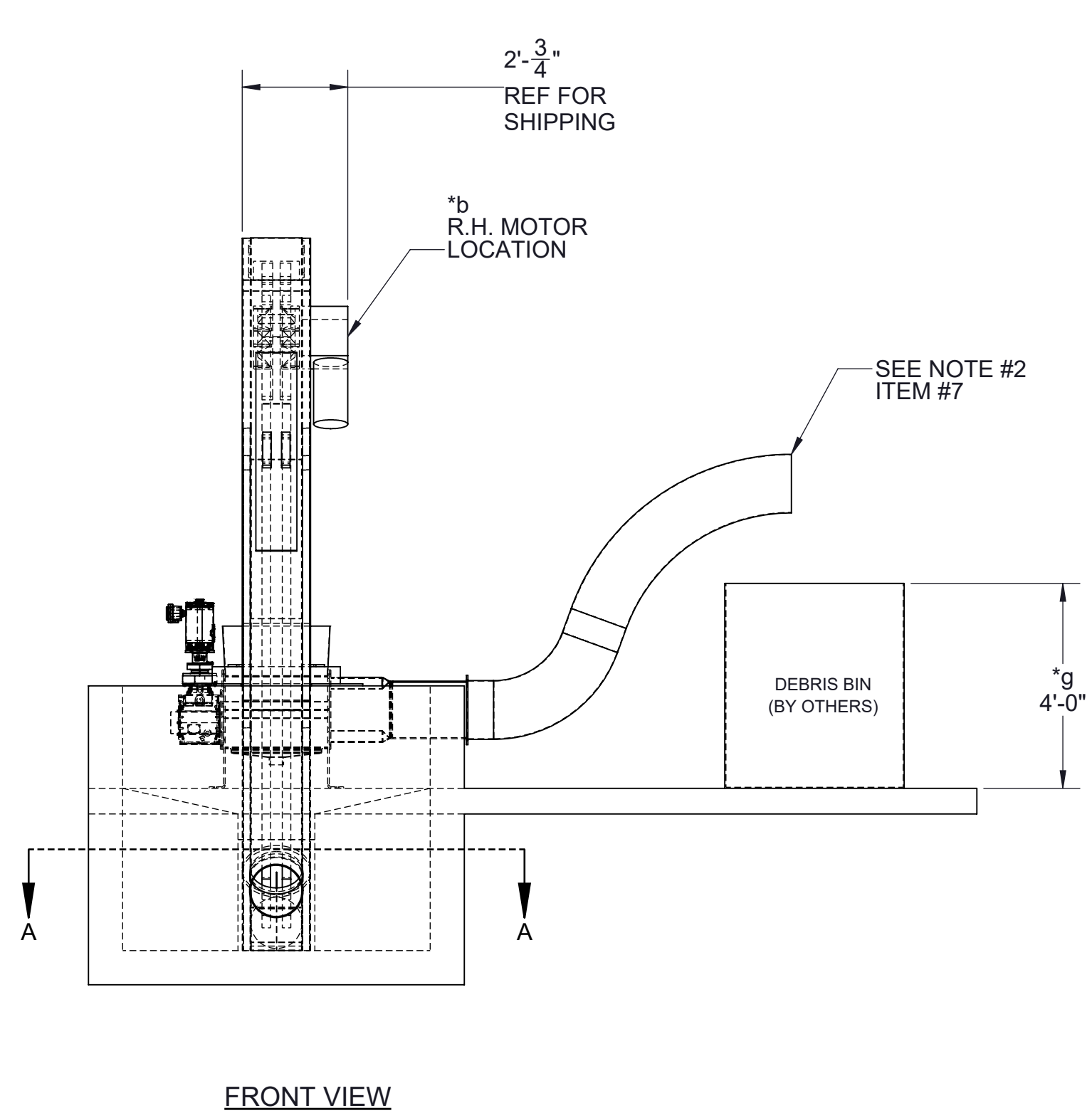
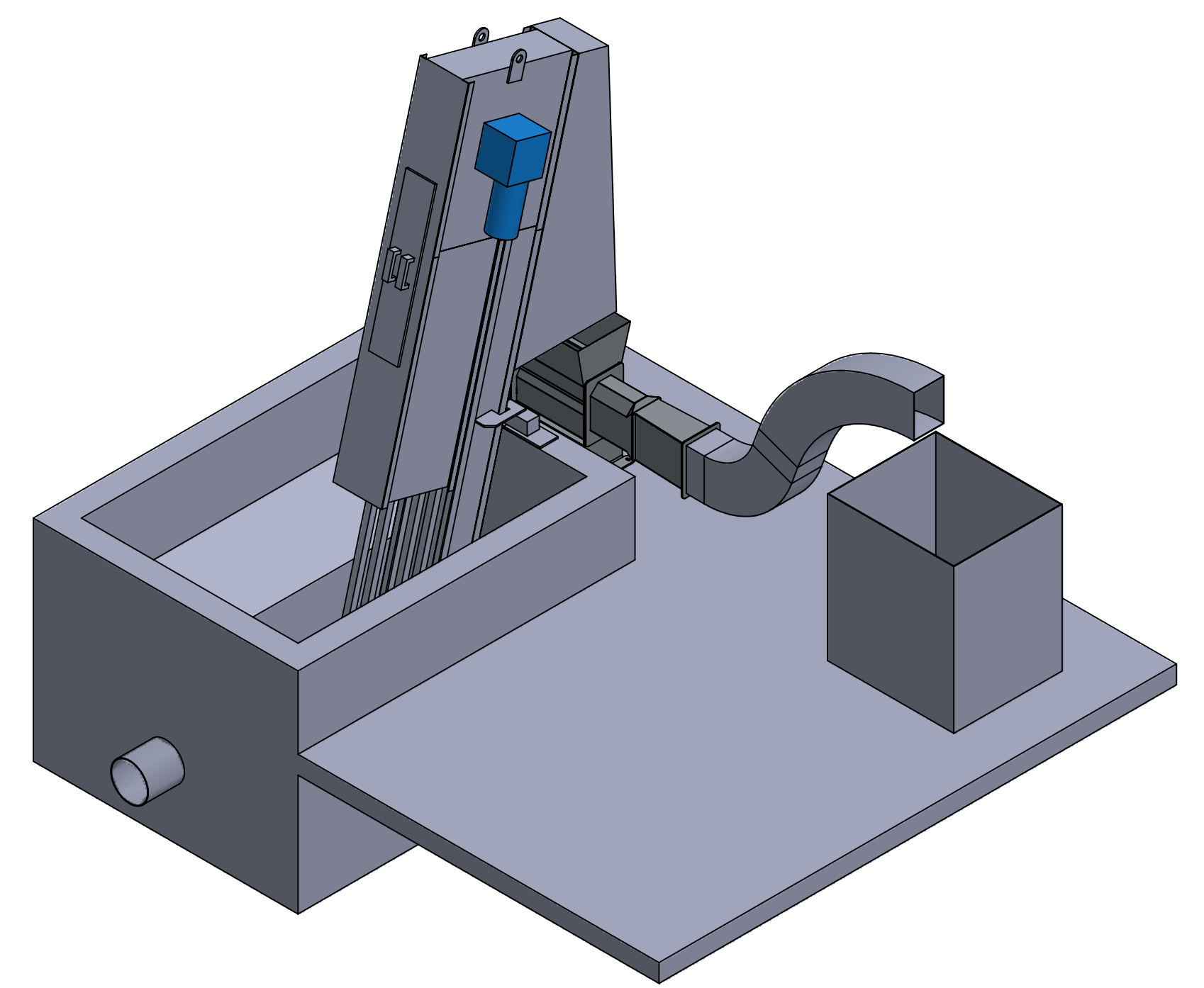
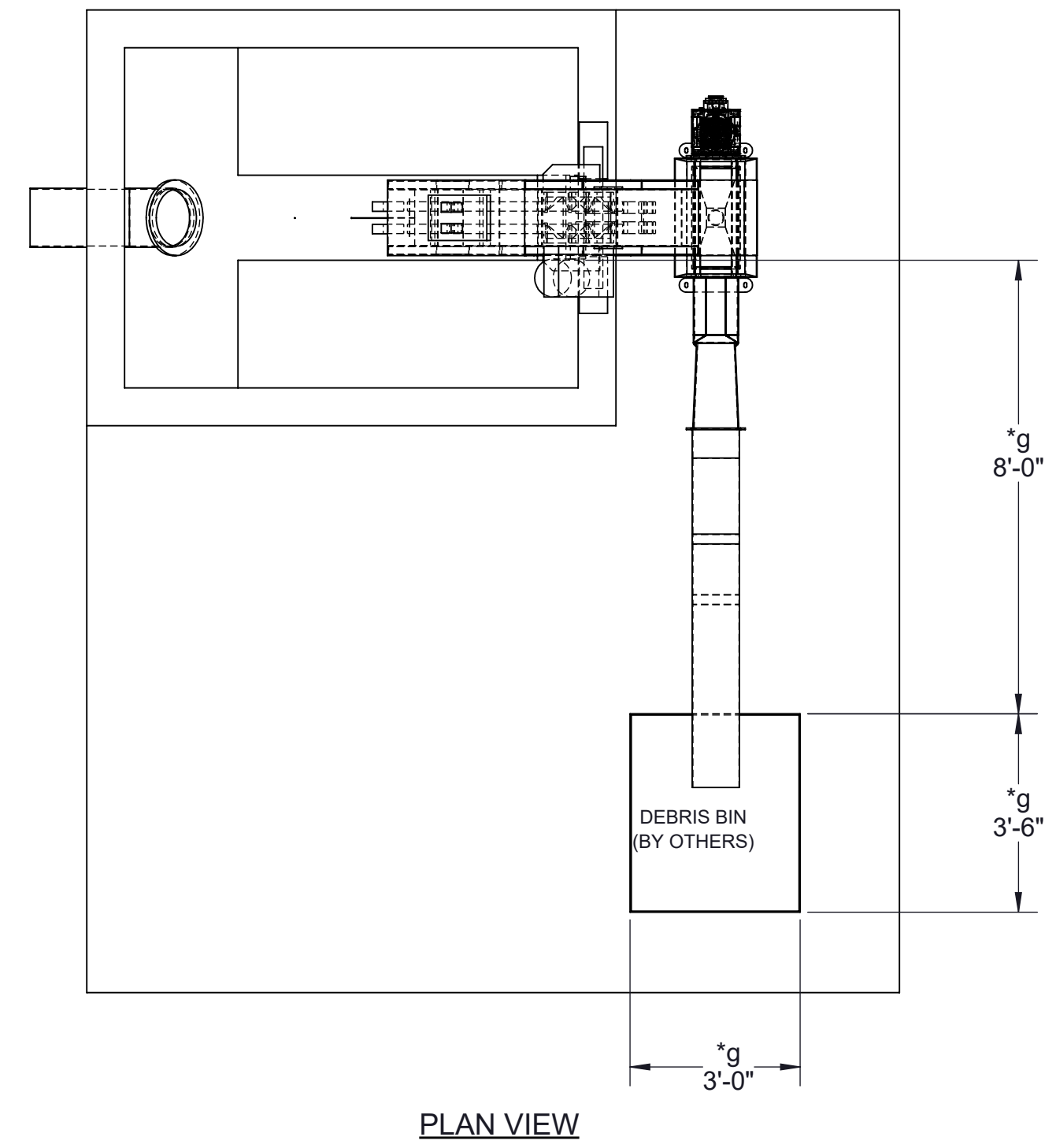

PROPOSAL

DRAWN	DATE
WDS	4/15/2025
CHECKED	DATE
WDS	4/15/2025
APPROVED	DATE
AP	4/15/2025



CONCEPTUAL
THIS PROPOSAL DRAWING IS BASED UPON THE INFORMATION AVAILABLE AT THE TIME AND MAY BE AFFECTED BY FUTURE SPECIFICATION, SCOPE, AND OTHER REQUIREMENTS. PLEASE BE ADVISED THAT DUPERON CORPORATION RETAINS THE RIGHT TO REFUSE, WITHDRAW, OR NEGOTIATE THIS PROPOSAL AT ANY TIME PRIOR TO SIGNING MATERIAL CONTRACT.

EQUIPMENT TYPE
DUPERON CORPORATION Flex Rake® IQ

PROPRIETARY
THIS MATERIAL IS THE EXCLUSIVE PROPERTY OF DUPERON CORPORATION AND MUST BE RETURNED TO DUPERON IMMEDIATELY UPON REQUEST. THIS MATERIAL AND THE INFORMATION ILLUSTRATED OR CONTAINED HEREIN MAY NOT BE REPRODUCED, COPIED, USED OR TRANSMITTED IN WHOLE OR IN PART IN ANY WAY WITHOUT THE PRIOR WRITTEN CONSENT OF DUPERON CORPORATION - SAGINAW, MI, USA

SITE NAME
TRABUCO CANYON, CA ROBINSON RANCH WWTP

SIZE	PROPOSAL NUMBER	REV
D	P13947	0
SCALE	SHEET	1 OF 1
1:32	1	1

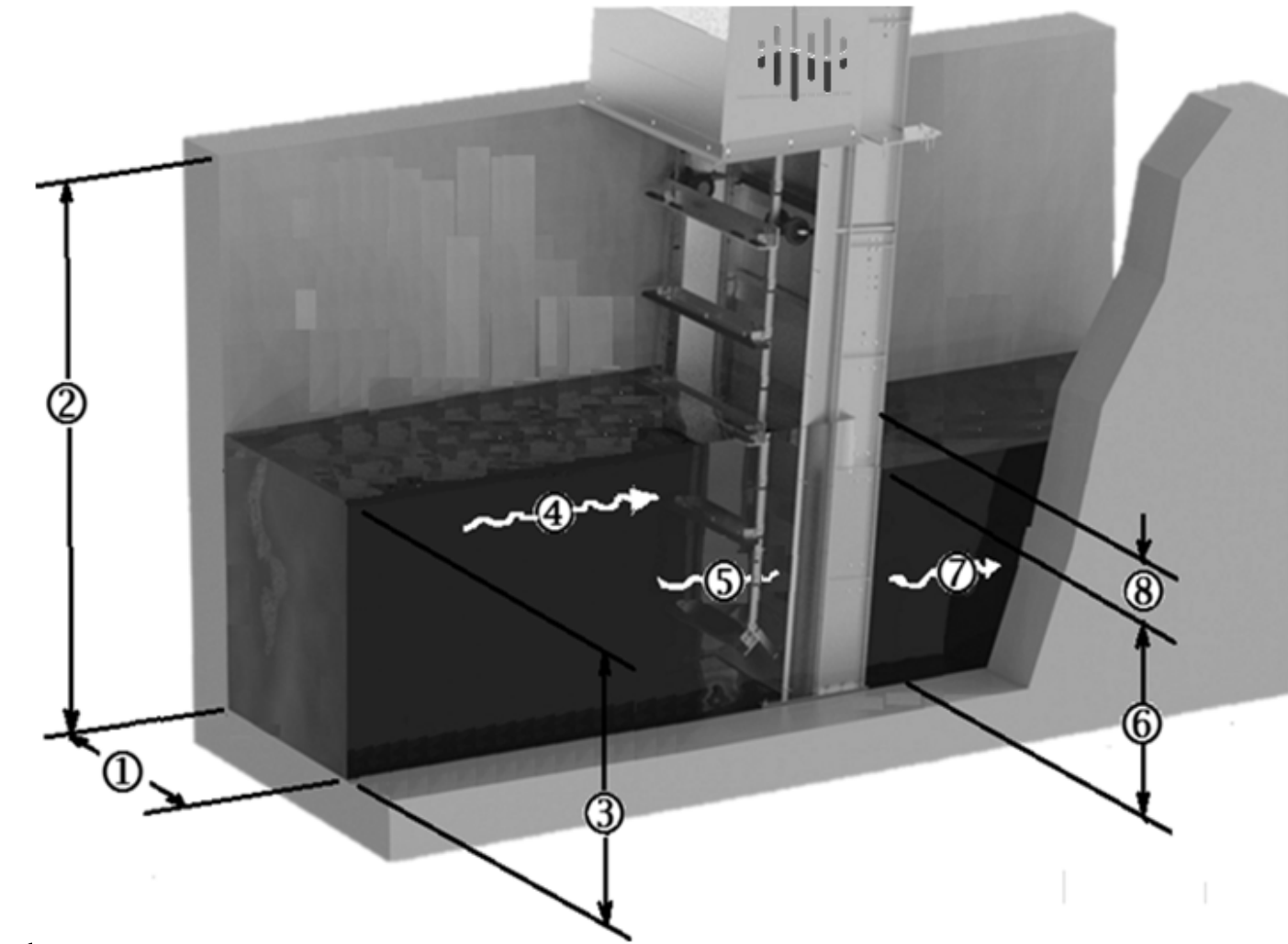

Date: 4/18/2025

Project: Robinson Ranch WWTP Trabuco Canyon

DC #: Proposal P13947 R3

Notes: Channel Dimensions 1.5 ft wide x 3.17 ft depth

Peak Flow = 1.1 MGD with minimum downstream water level
 1 screen in operation during peak flows

Average Flow = .6 MGD with minimum downstream water level
 1 screen in operation during average flows

The minimum downstream water levels noted below are selected to minimize settling and promote best capture.
 Confirmation that these water levels can be maintained is required.

Case No.	Prod. Model	Flow Rate (MGD)	Opening Between Bars (in.)	①		②		Percent Blinding (%)	Bar thickness (in.)	Side Close-outs (ft.)	Base Plate Height (ft.)	Flow Coeff. (1/C ²)	③	④	⑤	⑥	⑦	⑧	Comments	
				Channel Width (ft.)	Unit Width (ft.)	Channel Depth (ft.)	Upstr. Water Level (ft.)						Upstr. Velocity (fps)	Slot Velocity (fps)	Downstr. Water Level (ft.)	Downstr. Velocity (fps)	Head Loss (in.)			
1	FRIQ	1.10	0.25	1.50	1.50	3.17	25%	0.25	0.50	0.04	1.43	1.28	0.89	3.66	1.00	1.13	3.36	Peak flow, 25% blinding, estimated DSWL of 1.00 ft		
2	FRIQ	0.60	0.25	1.50	1.50	3.17	25%	0.25	0.50	0.04	1.43	1.11	0.56	2.31	1.00	0.62	1.34	Average flow, 25% blinding, estimated DSWL of 1.00 ft		

Duperon requires a minimum of 1.00 ft water depth when the unit is in operation to keep the SSTL FlexLinks lubricated and ensure an optimal amount of screening area. This does not apply to LowFlow, FR IQ, and GTS units.

Head loss is calculated using Bernoulli equation: $HL=(1/C^2)*(V^2-v^2)/(2g)$. Flow coefficient (1/C²)=1.43 should be used for general applications (FP,HD,SCT,FRIQ≥.62,HFR≥.62). (1/C²)=.99 is used for teardrop bars (LF,FPFS,FPFS-M,FRIQ≤.5,HFR≤.5 GTS). †

At design average flow conditions, approach velocities should be no less than 1.25 fps, to prevent settling. ††

Satisfactory designs have provided for velocities of 2 to 4 fps through the openings of mechanically cleaned screens.†††

References: †Hydraulic Similarity of Headloss Predictions (WEF abstract) 2010, L.Botero, M.Woodley. ††Recommended Standards for Wastewater Facilities (10 States), 61.122 (2014). †††WEF MOP 8 5th ed. 2010.

DUPERON®
FLEXRAKE IQ®
RESPONSIVE RESILIENCY™



SMART RAKING™

Duperon created the FlexRake IQ with all the simplicity and reliability of the original FlexRake and added a new level of resilience for today's (and tomorrow's) challenging plant conditions. The FlexRake IQ focuses on Smart Raking™ enhancements and automated response to manage heavy solids loading events. The FlexRake IQ provides a new option for greater flexibility over a broader range of conditions.

THE DUPERON DIFFERENCE

AUTOMATED, REAL-TIME RESPONSE

- *Smart LogIQ™ sequence of operations automatically responds to changing flow and debris conditions*

OPTIMIZED HYDRAULIC PERFORMANCE

- *Ideal during heavy solid loading or first flush events*

INCREASED DEBRIS REMOVAL

- *Up to 4x the debris removal capacity*

ENHANCED DEBRIS MANAGEMENT

- *Improved grit/rock handling*

PROCESS RESILIENCY

- *With reliable continuous cleaning; Jam Evasion™ technology and rapid re-engagement, the FlexRake IQ can remove large debris without disruption and re-enter into the bar screen quickly to avoid blinding, flooding, and bypassing*

LONG PRODUCT LIFE

- *Re-imagined FlexLink™ is designed for long life at higher speeds*

DUPERON®
FLEXRAKE IQ®
 RESPONSIVE RESILIENCY™

The original FlexRake technology transformed preliminary liquid/solids separation. The IQ Platform benchmarks the simple and reliable FlexRake design principles and adds next-generation smart features for a new level of adaptability.

An **INTELLIGENT** screening system that knows what to do & when to do it

The FlexRake IQ combines **TWO SMART FUNCTIONS:**

1 SMART LogIQ™

Responds to current debris loading and hydraulic conditions by adjusting the operating speed and discharge rate automatically, without operator intervention.

2 SMART RAKING™

Proven FlexLink™ technology made its mark by eliminating lower sprockets, becoming its own frame and operating without shutdowns from large debris. Redesigned components enhance screen cleaning and solids handling.



BACKED BY PROVEN PERFORMANCE IN OVER **1800 INSTALLATIONS AND 25+ YEARS** OF APPLICATION EXPERIENCE, THE FLEXRAKE IQ PROVIDES RESPONSIVE RESILIENCE.

USACE DEFINITION OF
RESILIENCE

Resilience is the ability to **ANTICIPATE, PREPARE** for and **ADAPT** to changing conditions and **WITHSTAND, RESPOND** to, and **RECOVER** rapidly from disruptions

(Executive Order 13563)

1 SMART LogIQ™
 SEQUENCE OF OPERATIONS

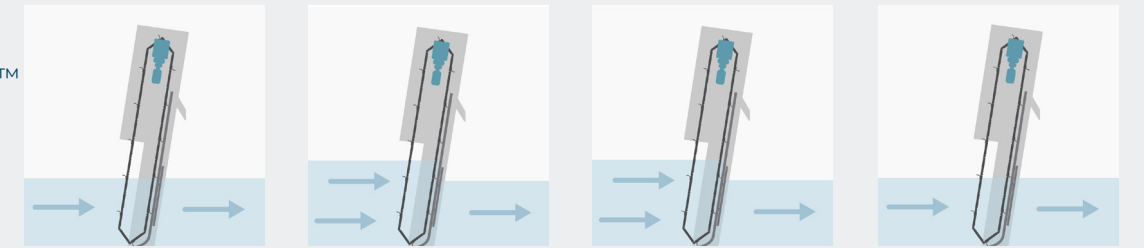

SITE CONDITIONS	FLOW	average flow	increasing flow and debris load	decreasing flow/debris load	average flow
	HEADLOSS	in range	increasing	decreasing	in range
SMART RAKING™	SPEED	normal	increased as needed	reducing	low

2 SMART RAKING™
 ENHANCED SCREEN CLEANING



A
Re-engineered scraper provides up to 4x debris removal capacity and increased strength



B
Patent-pending re-engineered FlexLink™ is designed for additional speed capabilities and long product life



C
Rapid re-engagement removes large debris without shutdown to return scraper into the bar screen faster



D
Re-configured geometry of design allows for lowest possible engagement and better settled solids handling

		FLEXRAKE®	FLEXRAKE IQ® RESPONSIVE RESILIENCY™
FLEXRAKE® DESIGN PRINCIPLES	Design simplicity	✓	✓
	Multi-rake unit with no in channel sprocket, bearings or tracks	✓	✓
	FlexLink™ Jam Evasion™ technology	✓	✓
	25+ years of application experience	✓	✓
	Low maintenance	✓	✓
	Ease of operation	✓	✓
	Long product life	✓	✓
SMART LogIQ™	Automatically matches speed and discharge rate in real-time for changing channel conditions		✓
SMART RAKING™	Up to 4x increased debris removal capacity		✓
	Increased speed capability		✓
	Improved grit/rock handling		✓
	Rapid re-engagement returns scrapers to the screen faster		✓

PRODUCT DATA

UNIT WIDTH	2 ft to 10 ft
UNIT LENGTH	Up to 100 ft
BAR OPENINGS	1/8 in or greater
ANGLE OF INSTALLATION	Vertical to 45 degrees
MATERIALS OF CONSTRUCTION	Standard 304 SSSL, available in 316 SSSL
TYPICAL MOTOR	1 hp
CLEANING FREQUENCY	Entire screening field cleaned every 7 seconds at max speed
CONTROLS & OPERATIONS	Base packages from float level control to sophisticated automation

DUPERON®
WASHER COMPACTOR
 DUAL AUGER UNIT

Washer compactors automate the solids handling process efficiently and provide a bottom-line impact to meet hauler requirements and reduce landfill volume. The Duperon Washer Compactor is a patented, dual auger unit, specifically designed to handle the debris variations that a FlexRake® could potentially discharge. It combines mechanical simplicity and strength to achieve reliable performance and lower disposal costs.

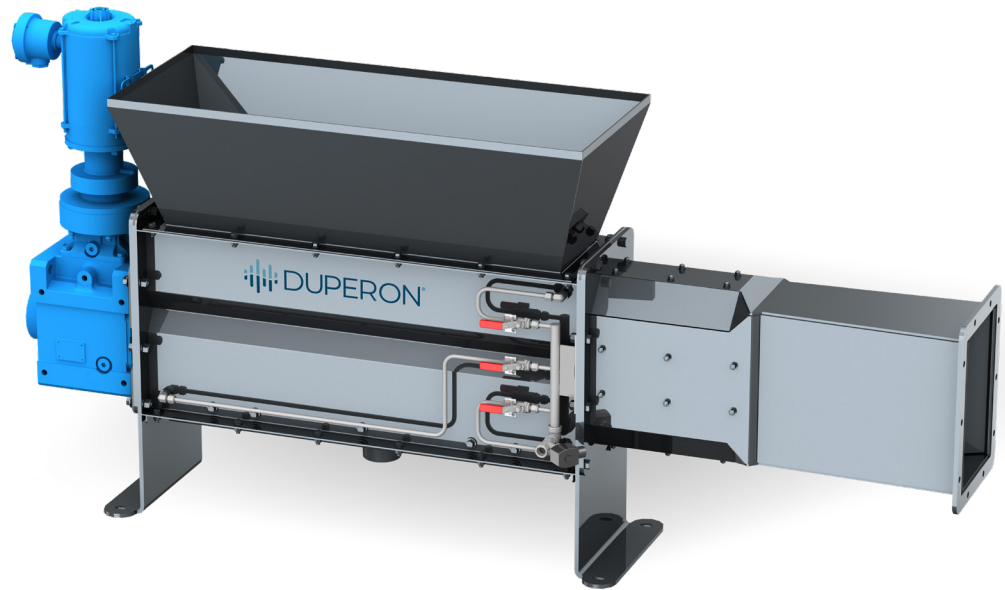

THE DUPERON
DIFFERENCE

WHAT GOES IN, COMES OUT

- *Positive displacement from patented dual augers processes debris forward, prevents slipping, wrapping, clinging, and bridging*

CONSISTENT COMPACTION

- *The self-regulating compaction zone delivers consistent dry solids, regardless of debris or volume in non DEO applications*

FLEXIBLE DISCHARGE

- *The Discharge Extension Option transports compacted screenings up to 40 ft in any direction without additional mechanized conveyance*

HIGH PERFORMANCE TO IMPACT BOTTOM-LINE

- *Reliably provides up to 84% volume reduction and 60% dry solids to minimize odor, meet hauler standards, and reduce landfill costs*

WASHER COMPACTOR FEATURES

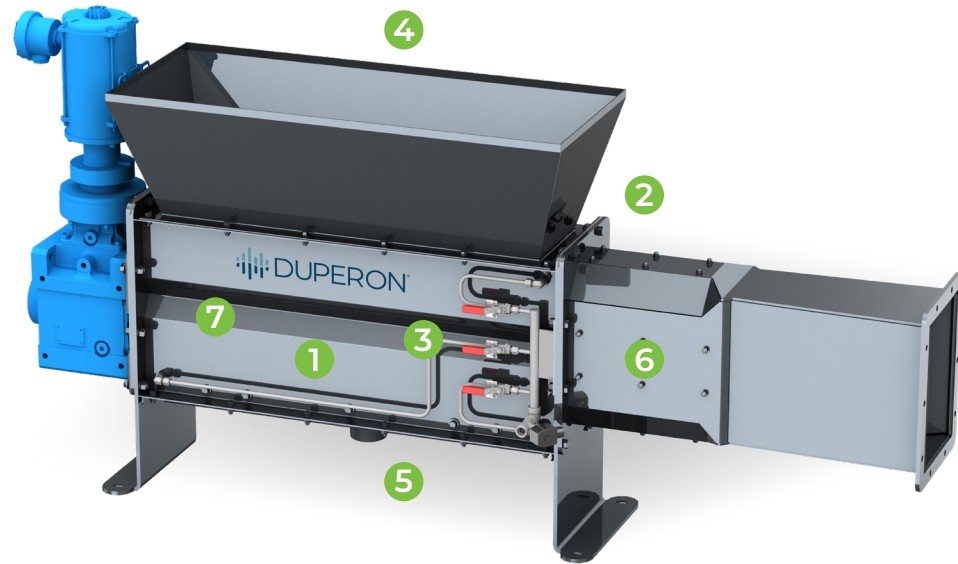

- 1 HOUSING GEOMETRY**
Controls potential for "slip flow" when processing grease, septage and other similar debris
- 2 NON-BATCHING**
Continuous flow
- 3 SELF-CLEANING STRAINER**
Eliminating brushes and relieves clogging
- 4 DESIGNED FOR DUTY**
Designed to process debris variations that a FlexRake® could occasionally discharge, like rocks, grease, clothing, concrete and metal up to 4 inches
- 5 NON-CLOGGING FLOOD WASH PORT**
Ideal for non-potable water
- 6 NO FIXED REDUCTION COMPACTION**
A proprietary self-regulating compaction zone controls pressure, regardless of volume for consistent dry solids in non DEO applications

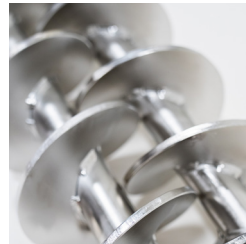

- 7 POSITIVE DISPLACEMENT**
Counter-rotating patented dual augers process debris forward, preventing slipping, wrapping, clinging and bridging

HOW IT WORKS

The Duperon® Washer Compactor is a powerful system that uses self-cleaning dual augers in a counter rotation to prevent wrapping and to help separate organic and inorganic materials. The dual augers use positive displacement, to continuously move debris forward for cleaning, compaction, and discharge. Flood washing ports clean screenings and return organics back to the channel. A proprietary self-regulating compaction zone (in non DEO applications) provides consistent pressure, regardless of volume and debris composition.

Unlike other technologies, the Duperon Washer Compactor typically compresses debris before it enters the discharge chute, so it does not rely on fixed reduction compaction (using the friction of screenings in the chute to compact). The internally controlled compaction allows Duperon equipment to push a plug column with little to no resistance to extended locations. The captured solids are delivered in an enclosed chute to the desired discharge point, with minimal odor and vector-free.

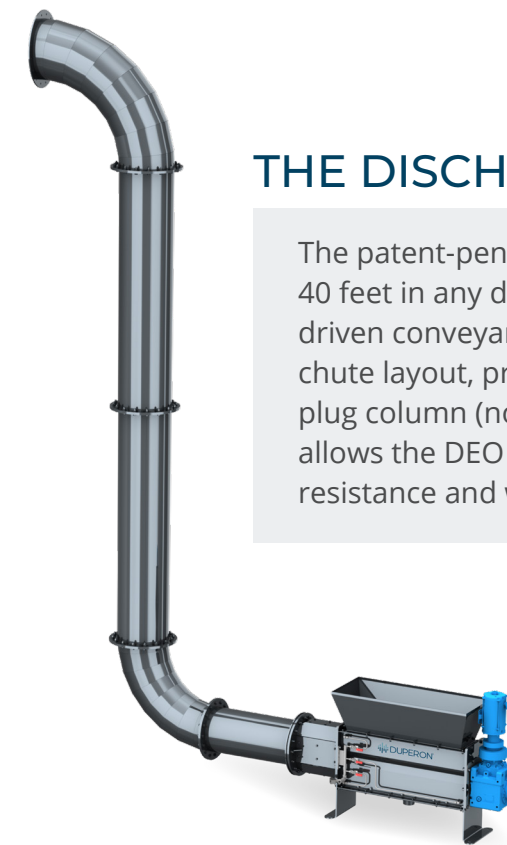

THE DISCHARGE EXTENSION OPTION

The patent-pending Discharge Extension Option (DEO) can transport debris up to 40 feet in any direction, even vertically, eliminating the need for additional motor-driven conveyance systems. The dual augers, combined with the geometry of the chute layout, produce backpressure. This backpressure allows the weight of the plug column (not friction from the chute) to dewater and compact debris. This allows the DEO to easily transport compacted screenings long distances, without resistance and without requiring the augers to extend to the discharge point.

THE DEO PROVIDES SIGNIFICANT COST SAVINGS BY:

- Reducing the length of the bar screen extending multiple levels
- Eliminating additional conveyance, motors and associated maintenance
- Eliminating manual labor and debris handling of captured screenings

WASHER COMPACTOR DISCHARGE CHUTE ACCESSORIES



HEAT BLANKET:
The Washer Compactor hopper, compaction zone and discharge chute can be thermally protected from cold temperatures with the addition of the Heat Blanket with integral heat trace.



BAGGER:
The Bagger System attaches to the discharge chute for applications where bag dispensing and odor control are required. Included is a 90 meter length of continuous feed bags.



DROP SLEEVE:
This flexible Drop Sleeve is an economical way to direct and contain downward debris discharge. Also used where waste container hauling may cause damage to metal discharge chutes.



CASTER ASSEMBLY:
Optional casters allow for flexible placement of the Washer Compactor and simple movement of the unit.



HOPPER LEVEL SENSOR:
Used in applications where a sluice discharges into the washer compactor. If the float trips, sluice water will turn off to avoid the hopper overflowing.



HOPPER BYPASS:
A 6 inch bypass plumbed with Fernco styie fittings to avoid hopper overflowing, drains excess debris back into the channel in front of the bar screen to be re-captured.

	BODY SIZE 1	BODY SIZE 2	BODY SIZE 3
A Typical hopper height (in)	38	38	38
B Hopper length (in)	27	43	67
C Distance between washer compactor legs (in)	24	40	64
D Overall length (in)	69	85	109

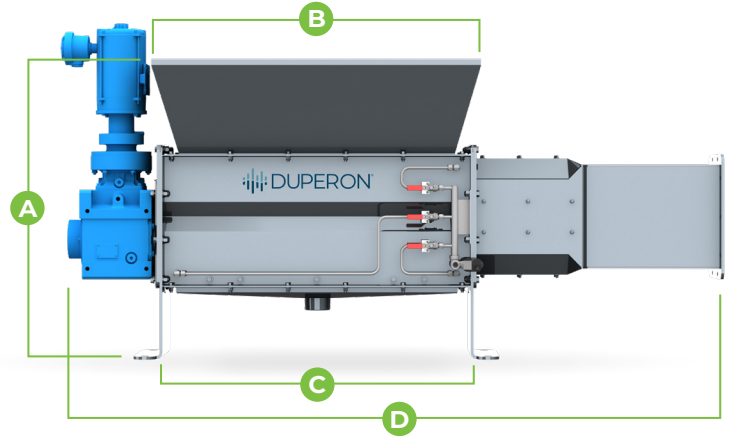

PRODUCT DATA

SIZING	3 sizes to accomadate site flow and capacities
WATER	<ul style="list-style-type: none"> Utilizes filtered effluent or municipal water Washer consumes 3-10 GPM Requires 40 psi-60 psi Drain connection 3 in NPT Supply connection 1/2 in NPT
UTILITY	120/240 volt, 1 PH 240/480 volt, 3 PH (0.6 kW/2.3 kW/3.8kW)
DRIVE	1 hp, 3 hp, 5 hp inverter duty motors available
MATERIAL OF CONSTRUCTION	304 SSSL or 316 SSSL, SSSL spur gears (17 - 4 PH) Self-lubricating main auger bearings
BAR SCREEN FLOWS	Flows up to 100 MGD* *flow values are based on MOP8 values through a ¼ inch bar screen
PEAK CAPACITY	Available from: 30 cu ft/hr - 150 cu ft/hr
TYPICAL PERFORMANCE	Up to 84% volume reduction 30% - 60% dry solids 60% - 70% weight reduction Significantly decreases odor and fecal content
STANDARD CONTROLS	Packages range from simple start/stop to sophisticated automation Motor overload protection provided
OPERATION OPTIONS	Continuous while screen is running with off-delay capability to clear hopper
APPLICATIONS	<ul style="list-style-type: none"> Municipal wastewater Combined sewer overflow Pump stations Lift stations Industrial wastewater Other non-standard applications where debris is variable or difficult

**TRABUCO CANYON WATER DISTRICT
ENGINEERING/OPERATIONAL COMMITTEE MEETING | MAY 7, 2025**

ENGINEERING MATTERS

ITEM 5: DIMENSION WATER TREATMENT PLANT TRANSMISSION MAIN REHABILITATION

Trabuco Canyon Water District (District) operates the Dimension Water Treatment Plant (DWTP) in the City of Lake Forest. DWTP is one of the only local drinking water treatment facilities of its kind in Orange County and the District's only independent source of water with the capacity to serve all District customers. DWTP can process up to six cubic feet per second (cfs) of untreated water from Metropolitan Water District (MWD), which is conveyed to the District's service area via a 4-mile, 16" transmission pipeline (Transmission Main). The Transmission Main was originally constructed in 1964 although some portions have been replaced as part of road improvement projects, residential development, and overall system upgrades. The Transmission Main operates under high pressure and several major breaks in the pipeline occurred between August-November 2024. Consequently, the Transmission Main has been taken out of service and the District must depend on neighboring districts for water supply at a substantially higher cost and with no guarantee of reliability.

Staff has worked with their consulting engineers, Hazen and Sawyer (Hazen), to develop a repair plan focused on the most appropriate and effective construction methods to rehabilitate the Transmission Main. The analysis and comparison of available pipeline rehabilitation options with recommendations and estimated costs is summarized in Hazen's final Technical Memorandum (TM), included as Exhibit 1. Figure 7-1 of the Technical Memorandum, Project Phasing, shows the first phase which will repair/replace the most vulnerable 12,500 linear feet (LF) in order to restore water service as soon as possible. The second phase will repair/replace an additional 4,500 LF of pipeline and will be completed within 24 months following Phase I, during periods when water demands are low. The total estimated cost for Phase 1 is \$ 7,200,000 to \$10,300,000 million, depending on the level of contingencies applied to the construction estimate. The cost estimate will be refined as more information is known and construction bids are received.

Staff is developing an estimated cost of Phase 2 of the Transmission Main rehabilitation, subject to analysis of alignment alternatives and construction methods.

FUNDING SOURCE:

Capital Improvement Program

FISCAL IMPACT:

The current cost estimate for Phase I is \$7,200,000 for construction only and up to a total of \$10,300,000 with contingencies.

ENVIRONMENTAL COMPLIANCE:

Notice of Exemption

RECOMMENDED ACTION:

Receive information at the time of the meeting and take action(s) as deemed appropriate.

EXHIBIT(S):

1. [Final Technical Memorandum prepared by Hazen and Sawyer, April 23, 2025 \(excluding Appendices\)](#)

CONTACTS (staff responsible): PALUDI/LAUSTEN

**TRABUCO CANYON WATER DISTRICT
ENGINEERING/OPERATIONAL COMMITTEE MEETING | MAY 7, 2025**

ENGINEERING MATTERS

ITEM 6: PRELIMINARY 10-YEAR CAPITAL IMPROVEMENT PROGRAM

Maintaining a 10-year Capital Improvement Program (CIP) is integral to Trabuco Canyon Water District's (District) long-term financial planning efforts, including budgeting, debt management, and rate projections. Staff has developed the proposed 10-year list of CIP projects by revising the 5-year CIP that the District has been implementing as part of the 2022 Rate Study, adding remaining high-priority projects from the 2022 Asset Condition Assessment study, as well as adding other proposed new projects that address critical needs but were not identified in the Asset study.

Projects and programs in the preliminary 10-year CIP are categorized as either exclusively associated with a particular service or system (i.e. Potable Water, Wastewater, Recycled Water), or a combination of two systems (i.e. Wastewater and Recycled Water), or District-Wide. The preliminary 10-year total CIP budget, from Fiscal Year (FY) 2024-25 through FY 2033-34 is approximately \$70 million. However, the list of proposed projects is subject to Board of Directors review and approval during the current FY 2025-26 budget process and on an annual basis.

More information will be provided at the time of the Committee meeting.

FUNDING SOURCE:

Capital Improvement Program projects are typically funded through a combination of debt proceeds and cash reserves.

FISCAL IMPACT:

There is no authorized fiscal impact associated with the preliminary 10-year CIP, which is intended for planning and discussion purposes.

ENVIRONMENTAL COMPLIANCE:

Not applicable. Individual capital projects will be required to comply with environmental permitting requirements as necessary.

RECOMMENDED ACTION:

Receive information at the time of the meeting and take action(s) as deemed appropriate.

EXHIBIT(S):

None.

CONTACTS (staff responsible): PALUDI/LAUSTEN

ENGINEERING MATTERS

ITEM 7: UPDATE ON STATE WATER BOARD CROSS CONNECTION CONTROL PLAN HANDBOOK (CCCPH) REQUIREMENTS AND CROSS-CONNECTION CONTROL MANAGEMENT PLAN (CCCMP) ADOPTION

Background

On December 19, 2023, the State Water Board adopted the Cross-Connection Control Policy Handbook (CCCPH) which was effective on July 1, 2024. The CCCPH will replace the existing cross-connection control and backflow prevention regulations currently in Title 17. While the CCCPH has the same authority as a standard regulation, it is intended to provide more technical details and explanatory language than a standard regulation.

Implementation of the CCCPH requires the preparation and adoption of a Cross-Connection Control Plan, which will be due by July 1, 2025. The CCCPH does not remove any elements from existing cross connection control programs, so while public water systems (PWS) work toward compliance with the CCCPH, they must ensure they continue to effectively operate their cross-connection control programs in accordance with Title 17 of the California Code of Regulations, which includes at least annual testing of backflow prevention assemblies. These regulations and the CCCPH apply to all California public water systems (community, non-transient non-community, and transient non-community).

The primary objective of the CCCPH is the protection of public health through the establishment of standards intended to ensure a PWS drinking water distribution system will not be subject to backflow. In addition, by providing basic educational information on backflow prevention, the State Water Board intends to build a foundation of awareness within the regulated community regarding the importance of backflow protection and cross-connection control, leading to the implementation of a robust cross-connection control program for each PWS.

TCWD staff has participated in an inter-agency joint effort with other Orange County water agencies and cities to prepare a CCCP that is consistent with the adopted CCCPH and tailored to TCWD's needs and goal with the assistance of John Robinson Consulting. The review and plan development process has included monthly joint-agency meetings with representatives from the State Water Board and the Division of Drinking Water to review the draft plan template language for consistency with the adopted regulations.

Low Hazard Fire Protection Systems with AMR/AMI Meters

A significant potential financial impact to water purveyor customers Statewide is the required installation of backflow prevention accessories (BPA) to ensure cross-connection control and prevent the backflow of contaminants into potable water distribution systems, including, but not limited to residential low hazard fire protection systems (fire sprinklers). The proposed plan will include key criteria that will need to be met to eliminate the need of a BPA for homes with fire sprinklers.

Another key provision of the plan that benefits TCWD customers is the recently completed AMR/AMI Infrastructure Implementation Project that include water meters which monitor flow on a continuous basis and can notify the District of a backflow condition when it occurs. The proposed plan will allow District staff to monitor all water services in its database, and those connections that do not indicate a backflow condition will not require a BPA. Upon adoption of the plan, the District will provide written notification to residential customers with fire sprinkler systems of this requirement. Any AMR/AMI water meters that indicate a "Major Reverse Flow" condition will be followed up with a Hazard Assessment to determine the necessity of the installation of a BPA consistent with District standards.

Updated Information

Included with the staff report is the final draft CCCMP prepared with the assistance of John Robinson Consulting. District staff has contracted with TR Holliman & Associates to (1) perform quality assurance/quality control of the final draft; and (2) provide on-call cross-connection specialist services on an interim as-needed basis through the end

**TRABUCO CANYON WATER DISTRICT
ENGINEERING/OPERATIONAL COMMITTEE MEETING | MAY 7, 2025**

of the calendar year. The on-call services is necessary while select District staff complete the required training and certification to serve as a cross-connection specialist as required by the SWRCB.

District staff is working with general counsel to prepare the required ordinance and ordinance summary to publish in the newspaper in accordance with the adoption requirements.

FUNDING SOURCE:

General Fund – Professional Services

FISCAL IMPACT:

Cost Sharing Agreement Costs for Professional Services:	\$ 150,000
TCWD Plan Preparation Share: Approximately	\$ 6,000
<u>Plan QA/QC Services & On-Call Cross-Connection Specialist Services Budget:</u>	<u>\$ 4,200</u>
Total District Budget/Costs	\$ 10,200

RECOMMENDED ACTION:

Receive updated information at the time of the meeting and direct staff to take action(s).

EXHIBIT(S):

1. [Draft TCWD Cross-Connection Control Management Plan \(CCMP\)](#)

CONTACTS (staff responsible): PALUDI/PEREA

**TRABUCO CANYON WATER DISTRICT
ENGINEERING/OPERATIONAL COMMITTEE MEETING | MAY 7, 2025**

ENGINEERING MATTERS

ITEM 8: HARRIS GRADE TANK REPLACEMENT COST ESTIMATE UPDATE

Trabuco Canyon Water District (District) owns and operates two reservoirs at the Harris Grade Site, a 2.0 MG tank built in 1980 and a 420,000 Gallon tank built in 1965. Pursuant to the 2021 Sub-Area Master Plan for the proposed Saddleback Meadows residential development, the District and developer contemplated a joint project to replace the smaller tank and use the Harris Grade site for both the developer’s storage requirement and the additional District emergency storage needs. Although the developer is now pursuing a storage reservoir site dedicated solely to the development’s storage requirements, the District still has an interest in increasing its emergency water storage capacity and Harris Grade remains the most appropriate location. Consequently, and in order to plan appropriately for additional storage in the long-term Capital Improvement Plan, staff has retained Tetra Tech to update the Engineer’s Opinion of Probable Construction Costs for a 1.7 million gallon (MG) steel tank, as this is the largest steel tank that can be constructed on the Harris Grade site. The construction cost estimate, which is based on current market conditions and assumes construction to begin in 2027, is \$7,200,000 (\$10,320,000 with contingencies).

FUNDING SOURCE:

General Fund

FISCAL IMPACT:

\$9,130 in consulting fees

ENVIRONMENTAL COMPLIANCE:

Not Applicable

RECOMMENDED ACTION:

Receive information at the time of the meeting and take action(s) as deemed appropriate.

EXHIBIT(S):

1. Harris Grade Reservoir Engineers Estimate prepared by Tetra Tech

CONTACTS (staff responsible): PALUDI/LAUSTEN

**TRABUCO CANYON WATER DISTRICT
HARRIS GRADE RESERVOIR SITING STUDY**

DATE: April 16, 2025
Project No.: 200-09339-25001

ALTERNATIVE 1A 1.7 MG Reservoir (Steel)					
Item No.	Description	Total	Unit	Unit Cost	Total
1	Mobilization and Demobilization	1	LS	\$ 340,000	\$340,000
2	Trench Excavation and Safety Measures	1	LS	\$ 20,000	\$20,000
3	Clear and Grub Site, Including Tree Removal	1	LS	\$ 70,000	\$70,000
4	Demolition of Existing 0.42 MG Steel Tank	1	LS	\$ 400,000	\$400,000
5	Clear Access Road	1	LS	\$ 30,000	\$30,000
6	Access Road Improvements	1	LS	\$ 90,000	\$90,000
7	Site Grading	1	LS	\$ 200,000	\$200,000
8	12-ft High Retaining Wall	1	LS	\$ 310,000	\$310,000
9	Implement Interim Erosion Control and BMP Maintenance	1	LS	\$ 150,000	\$150,000
10	Reservoir Subgrade Preparation and Tank Foundation	1	LS	\$ 120,000	\$120,000
11	Site Work, including Fencing and Paving	1	LS	\$ 410,000	\$410,000
12	1.7-MG Steel Reservoir and Appurtenances	1	LS	\$ 3,980,000	\$3,980,000
13	16" Pipe, CML&C Yard Piping	1	LS	\$ 250,000	\$250,000
14	16" Pipe, CML&C Pipeline to Live Oak Canyon	1	LS	\$ 300,000	\$300,000
15	Slope Anchors Along Pipeline to Live Oak Canyon	1	LS	\$ 30,000	\$30,000
16	Piping Modifications to Reservoir No. 1	1	LS	\$ 60,000	\$60,000
17	Altitude Valve and Valve Vault	1	LS	\$ 220,000	\$220,000
18	Isolation Valves	1	LS	\$ 100,000	\$100,000
19	Power Pole Relocation	1	LS	\$ 20,000	\$20,000
20	Electrical and Instrumentation/Control	1	LS	\$ 50,000	\$50,000
21	Landscape and Irrigation	1	LS	\$ 20,000	\$20,000
22	Disinfection, Startup, and Commissioning	1	LS	\$ 30,000	\$30,000
				Sub Total	\$ 7,200,000
				30% Contingency	\$ 2,160,000
				TOTAL	\$ 9,360,000
				TOTAL (2027 Construction)	\$ 10,320,000

Assumptions:

- 1) Mobilization and Demobilization is 5% of total.
- 2) Trench Excavation and Safety Measures is assumed 2% of excavation and pipe trenching.
- 3) Tank construction costs include an additional 25% of material costs for double handling of materials.
- 4) 2027 Construction cost assumes inflation of 5% per year from 2025.
- 5) This estimate does not include current marketplace factors such as tariffs and market volatility. The associated impacts to construction cost and schedule cannot be estimated at this time. It is advisable that the Client consider these factors and include an appropriate contingency for their planning purposes.

**TRABUCO CANYON WATER DISTRICT
ENGINEERING/OPERATIONAL COMMITTEE MEETING | MAY 7, 2025**

ENGINEERING MATTERS

ITEM 9: OTHER ENGINEERING AND OPERATIONS PROJECT UPDATES

1. Report on Completion of WWTP Handrail Replacement Project by District Personnel
2. Saddle Crest Development Update
3. District CMMS Asset Summary Update
4. Other Projects

RECOMMENDED ACTION:

Committee to receive project status updates at the time of the Committee Meeting.

EXHIBIT(S):

1. WWTP Handrail Replacement Project Summary and Photos

CONTACTS (staff responsible): PALUDI/PEREA/LAUSTEN

Handrail Installation Project

Overview:

The Wastewater Department recently completed a critical safety project involving the installation of handrails at the wastewater treatment plant. This project was undertaken to enhance employee safety, ensure regulatory compliance, and mitigate fall hazards around high-risk areas. The work involved furnishing and installing new handrails along the EQ basin and the West SBR, replacing outdated and inadequate railing that failed to provide complete perimeter protection.

Project Importance:

The installation of new handrails addressed a significant safety concern. The existing railings were insufficient and did not meet current safety standards, leaving sections of the facility exposed and increasing the risk of falls or accidents. Upgrading the handrails was essential not only for employee and public safety but also to ensure the facility maintained compliance with relevant safety and environmental regulations.

Cost Analysis:

By completing the project in-house, the District achieved substantial cost savings while maintaining control over the project schedule and quality of work.

Cost Category	Amount
Budgeted Amount	\$108,000
Vendor Quote	\$270,722
Material Cost (TCWD)	\$16,000
Labor Cost (TCWD)	\$4,000
Total In-House Project Cost	\$20,000

The project was completed using 20 hours of in-house labor, with a total expenditure of \$20,000—representing a **cost savings of over \$250,000** compared to contracting the work out. Additionally, the final cost came in well below the originally budgeted amount of \$108,000.

While we recognize that not every project can be done in-house, we carefully select those that are manageable without taking away from our primary duties and responsibilities. By doing so, we make better use of our resources, reduce costs, and ensure important improvements—like this handrail installation—that enhance safety and provide necessary protection.









**TRABUCO CANYON WATER DISTRICT
ENGINEERING/OPERATIONAL COMMITTEE MEETING | MAY 7, 2025**

OPERATIONAL MATTERS

ITEM 10: WATER SYSTEM UPDATES

The following is a brief report of the water system through **April 2025**.

Projects and Repairs

Water Operations staff performed and/or completed the following tasks and projects:

1. Excavated and removed 2 four-foot sections of 16" Main Transmission Line at DWTP for Pipe Splitting Testing
2. Rebuild customer meter services on Hamilton Trail
3. Rebuild customer meter services on Live Oak Canyon
4. Rebuild customer's boost pump discharge line
5. Serviced 85 valves in the Robinson Ranch service area
6. Installed Anodes on Filter #4 and began putting filter #4 back together at DWTP

Monthly Water System Operations Summary

The Monthly Water System Operations Summary is attached for the Committee's review. Any anomalies will be presented at the time of the Engineering/Operational Committee Meeting.

RECOMMENDED ACTION:

Committee to receive system status updates. No action required.

EXHIBITS

1. Monthly Water System Operations Summary

CONTACTS (staff responsible): PEREA/KESSLER

**TRABUCO CANYON WATER DISTRICT
ENGINEERING/OPERATIONAL COMMITTEE MEETING | MAY 7, 2025**

OPERATIONAL MATTERS

ITEM 11: WASTEWATER SYSTEM UPDATES

The following is a brief report of the wastewater system through **April 2025**.

Projects and Repairs

Wastewater Operations staff performed and/or completed the following tasks and projects:

1. Assisted with UPS replacement at Dove Recycle Pump Station.
2. Installed a new turbidity meter at the WWTP.
3. Cleaned and graded spoils yard at the WWTP.
4. Prepped and conducted a plant tour for Scouting of America group.
5. Performed weed abatement at WWTP per Orange County Fire Authority (OCFA) and Division of Safety of Dams (DSOD).

Sewer System Management Plan (SSMP) Report

The purpose of the program is to communicate on a regular basis with the public on the development, implementation, and performance of TCWD’s SSMP. Status updates on the work and type of work performed on the sewer system will be provided, including sewer line and manhole cleaning, system repairs, lift station cleaning, and updates from satellite facilities:

Sewer System Management Plan (SSMP) Monthly Update	
Total Sewer Line, Feet*	212,045
Total Sewer Line Cleaned (Ft) – Month	66,000
Total Sewer Line Cleaned (Ft) – Cleaning Cycle	93,340
Cleaning Cycle Period (Mos.) [Start date: 1/1/25]	4
Total Sewer Line Cleaned, %	44%
The Oaks at Trabuco – Pumping Frequency for the Month	13
O’Neill Park Sewer System Status	Ok
O’Neill Park Sewer System Repairs	None
SSMP Quarterly Report – <i>Next Quarterly Report</i>	2Q 2025
SSMP Program Audit – <i>Next Audit Report**</i>	June 2025

**This amount includes the OC Parks-owned O’Neill Park sewer system the District is contracted to clean.*

***Periodic internal audits shall be conducted, at a minimum every two years, with reports kept on file. The audit shall focus on evaluating the effectiveness of the SSMP and TCWD’s compliance with the mandatory elements of TCWD’s SSMP:*

Monthly Recycled Water System Operations Summary

The Monthly Recycled Water System Operations Summary is attached for the Committee’s review. Any anomalies will be presented at the time of the Engineering/Operational Committee Meeting.

RECOMMENDED ACTION:

Committee to receive system status updates. No action required.

EXHIBITS

1. Monthly Recycled Water System Operations Summary

CONTACTS (staff responsible): PEREA/ULLOA

TRABUCO CANYON WATER DISTRICT | RECYCLED WATER SYSTEM SUMMARY - 2025

RECYCLED WATER SUPPLY															
	MAX	JAN	FEB	MAR	APR	MAY	JUN	JUL	AUG	SEP	OCT	NOV	DEC	TOTAL	FIVE YEAR AVG
WWTP Reclaimed Water Production, AF	78.3	37.1	35.6	41.5										114.1	520.1
Reclaimed Reservoir Level, FT	1274.5	1,265.5	1,270.0	1,271.5										-	-
Reclaimed Reservoir Free Board, FT	25.5	9.0	4.5	3.0										-	-
Reclaimed Reservoir Storage, AF	145.5	94.6	118.8	127.7										-	-
Supplemental Domestic Water Added, AF	N/A	0.0	0.0	0.0										0.0	5.2

RECYCLED WATER SYSTEM DEMAND															
NON DOMESTIC WATER USER	ALLOC. AF	8% JAN	17% FEB	25% MAR	33% APR	42% MAY	50% JUN	58% JUL	67% AUG	75% SEP	83% OCT	92% NOV	100% DEC	TOTAL	ALLOC. %
Dahlia Court	8.2	0.04	0.02	0.0										0.06	0.7%
Dove Canyon Golf Course	106.7	12.49	5.1	4.8										22.39	21.0%
Dove Canyon Master Association	279.3	10.92	3.6	3.6										18.07	6.5%
Robinson Ranch	80.2	1.41	0.4	0.8										2.63	3.3%
Trabuco Highlands	159.7	3.26	27.4	0.2										30.83	19.3%
City of RSM	0.1	0.00	0.02	0.00										0.02	12.3%
Construction Water	N/A	0.00	0.0	0.0										0.00	N/A
Sakaida Nursery	1.1	0.00	0.0	0.0										0.00	0.0%
SMWD	N/A	0.00	0.0	0.0										0.00	N/A
TY Nursery	17.9	0.00	0.00	0.0										0.00	0.0%
TOTAL, AF	653.2	28.1	36.5	9.4										74.00	11.3%
PERCENTAGE OF NDW ALLOCATION/YEAR		4.3%	9.9%	11.3%											
TOTAL ANNUAL AVG. NDW AVAILABLE**	774.36														

URBAN RUNOFF CAPTURE AND REUSE															
DISTRICT FACILITY		JAN	FEB	MAR	APR	MAY	JUN	JUL	AUG	SEP	OCT	NOV	DEC	TOTAL	FIVE YEAR AVG
Shadow Rock Detention Basin Production		0.00	10.19	8.18										18.37	1.6
Dove Tick Creek Production*	Dry Season	5.5	5.3	5.8										16.6	45.0
	TCWD Portion	5.5	5.3	5.8										16.6	-
	SMWD Portion	0.0	0.0	0.0										0.0	-
Dove Lake Water Pumped		0.0	0.0	0.0										0.0	190.1
Dove Lake Free Board, Ft		10.3	3.2	0.0										-	-
Dove Lake Storage, AF		131.2	309.0	331.0										-	-
Total Rainfall, In.		0.9	2.4	5.2										8.5	16.2

* SMWD share of Dove/Tick Pump Station Dry Season Water is 50% of production.

** Based on 5-Year Average Reclaimed Water Reservoir Base Supply & Recycled Water Production

**TRABUCO CANYON WATER DISTRICT
ENGINEERING/OPERATIONAL COMMITTEE MEETING | MAY 7, 2025**

OPERATIONAL MATTERS

ITEM 12: MAINTENANCE DEPARTMENT UPDATES

The following is a brief report of work completed by Maintenance staff through **April 2025**.

Projects and Repairs

Maintenance staff performed and/or completed the following tasks and projects:

Water Operations

1. Schedule Duthie Power to remove mobile emergency generator from Field Office/Booster One site
2. New Dimension cleaned out attic space at Field Office/Booster One for Hydrotech Electric to inspect wiring issues and repair

Wastewater Operations

1. Receive two new WILO pumps for Via Alegre LS

District Fleet Upgrades & Other Projects

1. Clean, prep, inspect truck #17 for use
2. Clean, prep, inspect truck #10 for use
3. Service and inspect boat for use
4. Schedule Duthie Power to perform fuel tank replacement on TCWD Cummins Mobile generator
5. JPIA pressure vessel inspection
6. Weed abatement program
7. Prep two items for auction, one 2014 F250 service body and one pickup truck bed (removed for service body install); staff will proceed with the District's Surplus Property Disposal Policy on this matter.

RECOMMENDED ACTION:

Committee to receive system status updates. No action required.

EXHIBITS

None

CONTACTS (staff responsible): PEREA/STROUD

**TRABUCO CANYON WATER DISTRICT
ENGINEERING/OPERATIONAL COMMITTEE MEETING | MAY 7, 2025**

REGULATORY AND OTHER MATTERS

ITEM 13: OTHER MATTERS/REPORTS

Other Matters/Reports from the General Manager and/or District staff may be provided at the time of the Engineering/Operational Committee Meeting.

RECOMMENDED ACTION:

Hear Other Matters/Reports that may have arisen after the posting of the agenda.

EXHIBITS

None

CONTACTS (staff responsible): PALUDI/PEREA