



PROPOSAL FOR

## Master Plan And Condition Assessment Study (Project No. 2122-012)

Submittal Due Date: September 23, 2021 at 2pm

Trabuco Canyon Water District  
(Administration Office)

Attn: Ms. Lorrie Lausten, PE | District Engineer

32003 Dove Canyon Dr.

Trabuco Canyon, CA 92679





# TABLE OF CONTENTS

## **1. COVER LETTER & EXECUTIVE SUMMARY**

- Conflict of Interest Statement

## **2. SCOPE**

## **3. TEAM**

## **4. EXPERIENCE AND REFERENCES**

## **5. SCHEDULE**

## **6. BUDGET**

## **7. APPENDIX A**

- Example Master Plan Materials

## **8. APPENDIX B**

- Insurance
- Resumes







# 1 COVER LETTER & EXECUTIVE SUMMARY

PROPOSAL FOR MASTER PLAN AND CONDITION ASSESSMENT STUDY



Trabuco Canyon Water District  
 Ms. Lorrie Lausten, PE | District Engineer  
 32003 Dove Canyon Dr.  
 Trabuco Canyon, CA 92679



**Subject: Proposal for Master Plan and Condition Assessment Study (Project No. 2122-012)**

Dear Ms Lausten,

MKN & Associates, Inc. (MKN) is pleased to present this proposal to provide professional engineering services for the preparation of a Master Plan and Condition Assessment Study for your consideration. We acknowledge availability of the subject Request for Proposals (RFP) on August 26, 2021, Addendum No. 1, Addendum No. 2, and Available Documents on September 9, 2021.

**Executive Summary**

TCWD Criteria	MKN Highlights
<b>Qualifications and Experience</b> 25%	<ul style="list-style-type: none"> <li>• <b>Proven Project Manager.</b> MKN’s Project Manager, Tony Herda, PE, MBA is an industry leader in master planning having completed over 20+ master plans.</li> <li>• <b>Quality Control.</b> MKN’s Henry Liang, PE, led the completion of the South Coast Water District’s Infrastructure Master Plan, which included water, sewer and recycled water. He also brings experience on 20+ additional master plan efforts.</li> <li>• <b>Hydraulic Modeling.</b> Lead Modeler, Rob Lepore, GISP, has completed 90+ master planning and hydraulic modeling projects in central and southern california.</li> </ul>
<b>Understanding and Subject Matter Expertise</b> 25%	<ul style="list-style-type: none"> <li>• <b>Capacity Assessment.</b> MKN’s lead for Capacity Charges, Ben Caragan, CPA, MBA, is an expert in the field, having completed 7 capacity charge assessments and 17 financial analyses for public agencies.</li> <li>• <b>Condition Assessments.</b> MKN has completed over 40 lift station (LS) projects, and our technical lead Keenan Bull, PE, has completed 25+ LS condition assessments (19 in Orange County).</li> <li>• <b>CCTV and Manhole.</b> Our CCTV sub, Downstream Services, has extensive inspection (including CML&amp;C pipeline) experience, and our manhole survey sub, Borchard Survey, recently completed survey of 200 manholes for Emerald Bay Service District (sub to MKN).</li> </ul>
<b>Ability and Resources</b> 20%	<ul style="list-style-type: none"> <li>• <b>Deep Bench.</b> Our modeling team includes Tony Herda, PE, MBA; Rob Lepore, GISP; and Jason Wong, EIT, with additional company-wide resources if needed.</li> <li>• <b>Availability.</b> Tony will be fully available to lead and execute this project; <b>your project will be his #1 priority.</b> In addition, his team has the available time to meet the level of effort projections provided in Section 6 - Budget.</li> </ul>
<b>Project Costs</b> 15%	<ul style="list-style-type: none"> <li>• While MKN is one of the most experienced planning firms in Southern California, our rates are typically 10-15% less than our competition due to our lean, client-focused company structure. <b>This means better value for District ratepayers.</b></li> </ul>
<b>Ability to Meet Schedule</b> 15%	<ul style="list-style-type: none"> <li>• <b>Detailed Approach.</b> Our schedule includes a logical task sequence demonstrating a realistic schedule and understanding of interconnectivity of steps.</li> <li>• <b>Ample District Review.</b> Each deliverable includes (2) weeks of review time for District staff.</li> <li>• <b>Consideration of Field Tasks Impacts.</b> The various field tasks (i.e. CCTV, condition assessments, flow monitoring, etc) are timed to avoid overloading District staff and minimizing impacts to operations.</li> </ul>

**Our experience, proximity to the service area, and attention to critical details,** make MKN the ideal choice for preparation of this comprehensive study. This proposal shall remain valid for 90 days from the date of submission: September 23, 2021, and we affirm that our firm or team have no conflict of interest prohibited by law. We look forward to the opportunity to work with the District to deliver this critical project. Thank you for your consideration.

Anthony Herda, PE, MBA  
 Project Manager  
 aherda@mknassociates.us  
 626.660.4837

Ryan Rallagher, PE  
 Principal-in-Charge





# 2 SCOPE

PROPOSAL FOR MASTER PLAN AND CONDITION ASSESSMENT STUDY



## SECTION 2

# SCOPE

As requested by the Trabuco Canyon Water District (District or TCWD), this section includes our detailed scope that will serve as the basis for our negotiations upon selection. Each scope item (shown in gray box) is accompanied with our implementation methodology. The Scope of Work (SOW) incorporates and clearly identifies the sixteen (16) tasks requested by the District (signified by TCWD Task Number). In addition, the SOW includes our approach to project management and introduces several optional tasks for the District's consideration.

The District's Master Plan and Condition Assessment Study (Master Plan) includes multiple systems and various parallel tasks. Having extensive experience with similar efforts, MKN understands the importance of a clear road map. The following illustration provides an overview of the major tasks, deliverables, and workshops which are further detailed in the subsequent scope sections.

### MKN's Proposed Work Plan

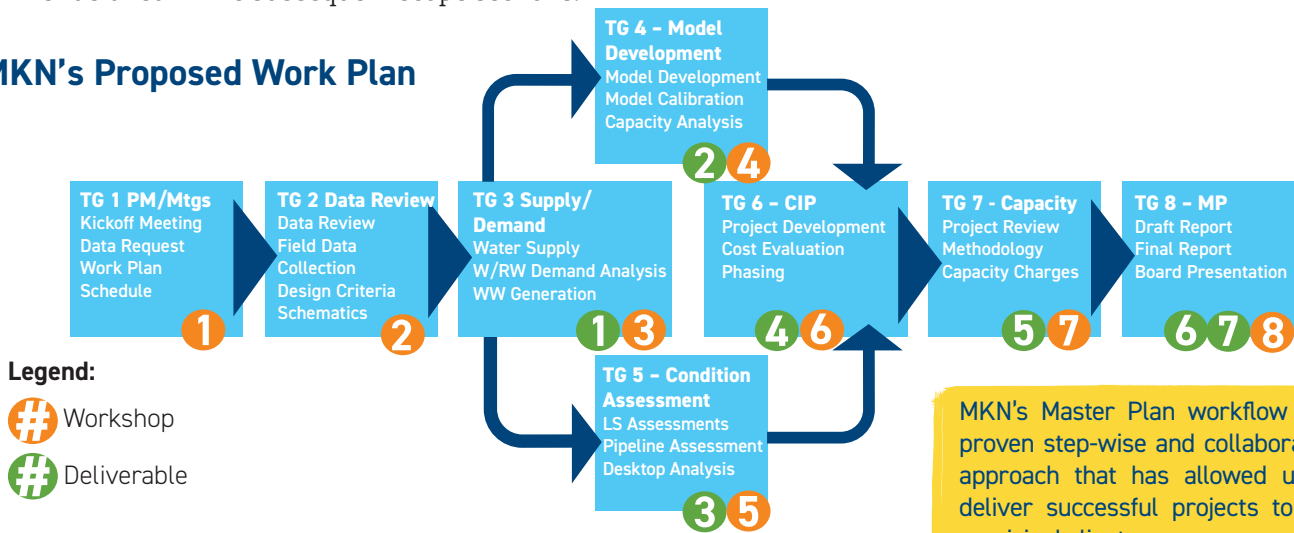

## 1

### TASK GROUP 1

## Project Management, Quality Control and Workshops

**Task 1.1 Project Management and QA/QA.** Overall project management, which includes supervision of in-house staff, planning and monitoring of contract budget and schedule, and coordination with the District and Consultant's project team will be conducted by the Project Manager. **Our Project Manager will communicate bi-weekly or more often with the District regarding progress status, data collection, and continuous review.** The Project Manager will issue monthly Progress Reports including an updated schedule in MS Project, a discussion of budget and schedule control, a review of work progress, upcoming milestones and deliverables, and a detailed invoice.

For an effort as complex as this Master Plan update, a comprehensive project management approach is a necessity. Our local Project Manager, Tony Herda, will utilize the following tools and MKN required practices to ensure project success:

- 1. Project Management Plan.** This standard form is completed at the start of the project and serves as our team's roadmap. While this is an internal document, we would be happy to share it with the District.
- 2. Microsoft Project Schedule.** As shown in Section 5, our detailed schedule includes a logical task sequence. The schedule will be updated on a monthly basis throughout the project.
- 3. Earned Value Analysis.** This may be the most critical element in communicating project status. This document includes budget, current expenditures and an estimate of completion. This report communicates to the District where the project is with regards to schedule and budget. **This will be submitted with each invoice so the District is always aware of project status.**

**Task 1.2 Meetings and Workshops.** MKN will facilitate a Kick-off Meeting and workshops at critical junctures during the project.

MKN will facilitate a series of workshops that correspond to the development of content for the Master Plan. Each workshop is planned to leverage our face-to-face communication; this means workshops are programmed to review the most recent deliverable and illicit input from District staff as well as confirm planned approaches for the next deliverable. **Our proposed Work Plan demonstrates our experience and outlines an efficient, collaborative approach to successful delivery of your integrated master plan.**

### MKN's Proposed Workshop Overview

Meeting	Target Date	Key Discussion Items	Relevant Deliverables Prior to Meeting
Workshop #1 Kickoff Meeting	11/22	<ul style="list-style-type: none"> <li>• Scope, Schedule and Budget</li> <li>• Data Review (status of requested data)</li> <li>• Communication</li> <li>• Report Approach</li> <li>• Condition Assessment – 3 mile Pipeline</li> </ul>	<ul style="list-style-type: none"> <li>• Meeting Agenda</li> <li>• Project Schedule</li> <li>• Data Request</li> </ul>
Workshop #2 Model Software and Field Data Collection	1/3	<ul style="list-style-type: none"> <li>• Model Software - Review results of evaluation and select preferred software</li> <li>• Field Data Collection Plan – Review proposed locations for Flow Monitoring, hydrant testing, Manhole Survey and CCTV.</li> <li>• Review Draft Condition Assessment Form</li> <li>• Confirm approach Task 2.5/2.6</li> </ul>	<ul style="list-style-type: none"> <li>• Meeting Agenda</li> <li>• TM 1</li> <li>• Maps for Flow, CCTV, &amp; Manhole</li> <li>• Condition Assessment Draft Form</li> </ul>
Workshop #3 Supply & Demand	2/9	<ul style="list-style-type: none"> <li>• Present Draft TM 2; discuss District comments</li> <li>• Review preliminary results of field data Collection efforts (TG 2)</li> <li>• Coordinate on Transmission CCTV</li> </ul>	<ul style="list-style-type: none"> <li>• TM 2</li> <li>• Meeting Agenda</li> <li>• District comment table format</li> <li>• Schematics (Task 2.5)</li> <li>• Design Criteria (Task 2.5)</li> </ul>
Workshop #4 Modeling Review	5/18	<ul style="list-style-type: none"> <li>• Present Draft TM 3; discuss District comments</li> <li>• Review CIP forms and dashboard</li> </ul>	<ul style="list-style-type: none"> <li>• Meeting Agenda</li> <li>• TM 3</li> </ul>
Workshop #5 Condition Assessment	4/26	<ul style="list-style-type: none"> <li>• Present Draft TM 4; discuss District comments</li> <li>• Review Asset Inventory</li> </ul>	<ul style="list-style-type: none"> <li>• Meeting Agenda</li> <li>• TM 4</li> </ul>
Workshop #7 CIP Development	6/30	<ul style="list-style-type: none"> <li>• Present Draft TM 5; discuss District comments</li> <li>• Capacity Charge Kickoff</li> </ul>	<ul style="list-style-type: none"> <li>• Meeting Agenda</li> <li>• TM 5</li> </ul>
Workshop #8 Draft Report/Capacity Charges	8/16	<ul style="list-style-type: none"> <li>• Present Draft MP; discuss District comments</li> <li>• Present Draft TM 6; discuss District comments</li> <li>• Discuss Board Input (Capacity Charges)</li> </ul>	<ul style="list-style-type: none"> <li>• Draft MP</li> <li>• Draft Capacity Charge TM 6</li> </ul>

**Task 1.3 Quality Control.** Our Project Manager and Quality Control Manager will coordinate on application of MKN's Quality Management System (QMS). This includes review of (7) deliverables (5 TMs, Draft & Final Master Plan)

MKN's quality management system (QMS) will be implemented by our Project Manager, Tony Herda, and QC Reviewer, Henry Liang, and confirmed by Principal-in-Charge, Ryan Gallagher.

MKN has dedicated line item budget and scheduled adequate time in our schedule to ensure each deliverable undergoes our thorough quality control process. **This means that District staff are only receiving the highest quality deliverables which reduces review time for District staff.**



# 2

## TASK GROUP 2 Data Request and Review

Recommended SOW:

**Task 2.1 Data Review (TCWD Task 1).** Review of previous 1999 Master Plan, planning documents, GIS database, supply sources information, as-builts, water, non-domestic water, and sewer demands, existing water, non-domestic water, and sewer systems, and other available pertinent records that may facilitate in the preparation of the Updated Master Plan.

MKN will issue a comprehensive Data Request prior to the Kick-Off Meeting. The Data Request will be an itemized list of data required to execute the Scope of Work. Each item will include a title, description, reference to the Scope of Work, the responsible party, and the date received. Electronic data will be maintained in a secure cloud-based database (i.e. Dropbox) organized according to the Data Request and accessible only by authorized personnel. At the conclusion of the project, a copy of the database will be issued to the District for your records.

**See Appendix A for a preliminary data request required to support execution of this Scope of Work.**

**Task 2.2 Manhole Survey (TCWD Task 7).** Consultant shall provide an optional item to survey 300 sewer manhole inverts.

As an optional task, MKN will oversee the survey of 300 manhole inverts. For this task, we are utilizing the services of Borchard Surveying, who recently completed a similar task for **approximately 200 manholes** in Laguna Beach. MKN proposes to prepare a list of priority manholes following review of initial GIS data. As recently completed for the Emerald Bay Service District, our surveyor will collect invert elevations for sub-inch accuracy and also collect internal photos of each manhole. MKN will link this information to the project GIS database for simple integration with the District's asset management software (Cartegraph). **MKN's approach maximizes value** by increasing accuracy of the hydraulic model effort and capturing additional visual condition information to support future asset management efforts.

**Task 2.3 Flow Monitoring (TCWD Task 8).** Perform dry-weather flow monitoring at strategic points in the sewer system for the purpose of model calibration. The consultant shall propose on an appropriate number of flow monitors and duration for the size of our system.

Following review of available District data, MKN will finalize meter locations. Based on our preliminary review, we believe five (5) locations for a 7-day period is adequate. Our scope includes minor traffic control (i.e. 35 mph, no intersection closures) at these locations.

MKN's proposed Flow Monitoring Program data will be paired with existing SCADA data. An accurate and reliable model, built on actual field data, can deliver more refined recommendations and often reduce the cost of a recommended CIP.

**As an optional task, MKN has provided scope for Wet Weather Flow monitoring at five (5) locations which would require a rapid response team and would supplement the dry weather flow data collected in the base flow monitoring effort.** These efforts will be provided by Downstream Services, Inc. who have been conducting business for over 35 years and are one of the leading pipeline services companies in California.

**Task 2.4 CCTV (TCWD Task 9).** Consultant shall provide an optional item to perform Closed Circuit Television Video (CCTV) sewer inspection on a Linear Foot (LF) basis on District sewer pipelines. The information gathered from the CCTV shall be utilized to evaluate the condition of these assets.

Based on our experience, the CCTV data is only useful if the sewers are cleaned ahead of the CCTV. To reduce cost, we will coordinate with District operations staff to complete this effort ahead of the CCTV. Typically, all pipelines should be reviewed on a five-year basis. To support the Master Plan development, we recommend 23,000 LF be included initially (12% of system). We will work with the District to identify these initial reaches and then prepare a prioritized, multi-year phasing plan for the balance; this will be included in the CIP.

**Value Driven CCTV Process.** MKN's CCTV inspection will focus on the most vulnerable pipelines and will result in data that can be easily translated into capital improvement projects.

**Task 2.5 System Schematics (TCWD Task 12).** Update/create hydraulic schematics of the domestic water, non-domestic water and sewer systems.

Based on our review of the existing systems, MKN will prepare three (3) sets of system schematics: integrated, system-level, hydraulic profile.

- » **Integrated Schematic.** MKN will prepare an integrated schematic showing the relationships between the water, recycled water and wastewater systems, the surrounding environment, and adjacent agencies.
- » **System Level.** MKN will prepare a system-level schematic of the water, recycled water and wastewater systems showing the transmission and connectivity between zones, sources, sewersheds and outfalls. **See Appendix A for a preliminary Water System Schematic.**

» **Hydraulic Profiles.** MKN will prepare a hydraulic profile for the water and recycled water systems showing the capacity and configuration of facilities and the connectivity between them. **See Appendix A for a preliminary hydraulic profile of the Harris Grade Pressure Zone.**

**Task 2.6 Design Criteria (TCWD Task 13).** Evaluate and recommend current water, recycled water, and sewer systems' design criteria.

MKN will review existing design criteria, compare the existing design criteria to a benchmark of industry standards, and recommend adjustments as needed to achieve the District's level of service requirements.

### 3 TASK GROUP 3 Supply and Demand

**Task 3.1 Water Supply (TCWD Task 2).** Analyze the adequacy and reliability of the Districts' water sources, identifying water quality issues, legal/institutional/contractual constraints, environmental documentation issues, and system issues as well as cost consideration.

Key elements of approach to evaluating water supply are summarized in the following table:

#### MKN's Key Focus Areas for Analyzing District Water Supply

Availability	Reliability	Sustainability
The availability analysis will consist of a review of the District's water rights, contracts and agreements with neighboring agencies and wholesalers, and other resources available for purchase in the region. We will identify any seasonal variation, administrative contingencies, or other conditions that would tend to limit availability.	The reliability analysis will focus on the District's ability to produce potable water from the sources identified in the availability analysis. We will identify constraints imposed by treatment capacity, trends in water quality that may require additional treatment, the condition and efficiency of treatment and transmission infrastructure, access to power and chemicals, and regulatory requirements. We will identify supply infrastructure vulnerability due to typical local hazards.	The sustainability analysis will focus on the District's ability to meet the needs of its customers today and in the future. We will review the ability of supply capacity to function under extreme weather variation and drought. We will review the adequacy of existing supply to support anticipated growth. We will identify supply sustainability vulnerabilities and estimate the level of growth the District can support before additional supply capacity is required.

**Task 3.2 Water and Recycled Water Demand Analysis.** MKN will review billing records to determine the location and magnitude of water sales by pressure zone and customer class. We will reconcile sales and deliveries to develop an understanding of demand variation and water losses. Demand variation will include derivation of Average Day Demand, Maximum Day Demand, Peak Hour Demand and Diurnal Curves by season and customer class. We will determine water deliveries to each pressure zone.

We will conduct an analysis of SCADA data to determine demand and customer behavior in each pressure zone.

For future projections, MKN will prepare a population growth model and apply our understanding of customer behavior to the future population. The analysis will be based on historical US Census data and related work done by the Orange County Environmental Management Agency at the District's request. MKN will prepare a summary of land use within District's Service Area as it relates to current and future demand. To the extent data are available, MKN will correlate water use, wastewater generation, and recycled water use to representative land use designations by area and by planning unit.

MKN's Approach to Demand Development yields accurate composite diurnal curves unique to the diversity and intensity of customers in each pressure zone.

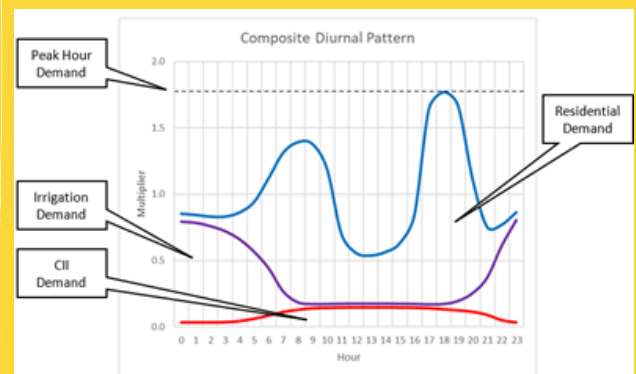

**Task 3.3 Wastewater Generation.** Based on water sales and wastewater treatment plant influent and effluent records, MKN will construct and calibrate a wastewater generation model to determine the location and magnitude of loading on the sewer system.

For the area served by the District’s Wastewater Treatment Plant, a graphic of the wastewater generation model is shown here.

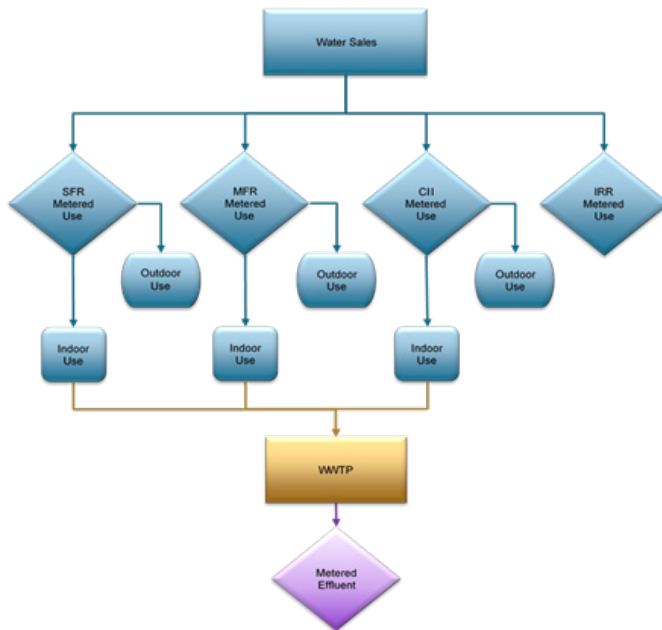

The data from this analysis will be used to establish Return to Sewer (RTS) factors that will be then applied to the established existing and future water demands values (Task 3.2) to create a loading framework that will serve as the basis for the wastewater model. Peaking factors for peak dry weather and peak wet weather will be created using the same data set and calibrated using data from the flow monitoring effort (Task 2.3).

## 4 TASK GROUP 4 Model Development

### Task 4.1 Software Evaluation (TCWD Task 3).

Identify and provide a new recommended GIS-based hydraulic modeling application to update modeling and design tools for domestic water, non-domestic water and sewer systems. The existing domestic and non-domestic models are in Innovyze InfoWater (models will be provided). MKN will procure quotes from up to three vendors, coordinate demonstrations and provide a technical memorandum to the District. We are assuming one in-house license and up to a five-year support contract will be required.

**Hydraulic Modeling Expertise.** With experience on over 90 hydraulic modeling efforts, our modelers bring extensive experience with Bentley, Innovyze, PCSWMM, among others. We will provide unbiased pros/cons along with budgeting information that assist in making the best selection for the District.

Following a review of the District’s GIS and its existing water and recycled water models, MKN will prepare an evaluation of up to three (3) water modeling platforms and up to three (3) sewer modeling platforms. MKN maintains software licenses with multiple hydraulic modeling providers and will coordinate a demonstration of models we have developed for other clients on the evaluated platforms. We will prepare a technical memorandum summarizing the evaluation process including quotes for the evaluated platforms per the District’s anticipated needs, a recommended water modeling platform, and a recommended sewer modeling platform.

**Task 4.2 Model Calibration (TCWD Task 4).** Update and calibrate the existing water and recycled water hydraulic models with recommended software. The finished models should accurately represent each system including supply sources, pump stations, PRVs, tanks, and pressure zones. Perform field visits and fire flow hydrant testing for the domestic water model, as necessary. Assume two (2) days of hydrant tests to be performed in the field by TCWD staff and observed and coordinated by the selected consultant.

MKN will import spatial data from the District’s GIS and/or from the existing water and recycled water models into the preferred water modeling platform as a basis for model development. We will program the physical characteristics and settings of all reservoirs, tanks, pumps, and control valves based on our review of the GIS and as-built drawings of facilities. We will verify pipe connectivity and pressure zone boundaries. We will spatially allocate demand per Task 3.1. We will validate the functionality of the models with initial testing simulations.

MKN will guide and oversee the collection of hydrant flow data for two (2) days in the field. We will utilize the results of hydrant flow testing to perform a steady state calibration on the water and recycled water models. **Our goal is a tolerance between field data and modeling results within 10% or 10 psi at all test locations and within 5% or 5 psi at 75% of locations.**

Based on design criteria parameters for flow, pressure, velocity, demand, and firefighting, we will preprogram up to three (3) water modeling scenarios under existing, near-term and long-term demand conditions.

### Task 4.3 WW Model Development (TCWD Task 6).

Develop a hydraulic sewer model with the recommended software. The finished model should accurately represent the sewer system including lift stations and manholes. Perform field visits when necessary to confirm critical as-built info. Assume the existing sewer geodatabase is substantially complete with manhole locations and pipe diameters. The system has 195,000 LF of sewer pipelines, 47,000 LF of sewer force mains, 812 Sewer Manholes, and 8 Lift Stations.

MKN will import spatial data from the District's GIS into the preferred sewer modeling platform as a basis for model development. We will use the manhole survey (if available) and as-built drawings as a basis for defining the collection system geometry and verifying direction of flow. We will program the physical characteristics and settings of all lift stations and forcemains based on our review of the GIS and as-built drawings of facilities. We will validate the functionality of the models with initial testing simulations. We will spatially allocate wastewater generation per Task 3.1. We will validate the functionality of the model with initial testing simulations.

MKN will analyze flow monitoring data (if available) and telemetry data from lift stations and the wastewater treatment plant outfall to develop diurnal curves for wastewater generation. We will review the flow monitoring data (if available) for evidence of inflow and infiltration. In the event we find no evidence of inflow and infiltration, we will consult with neighboring agencies regarding their knowledge of and their methods for estimating local occurrence of influent and infiltration and apply accordingly. We will adjust the loading to bring modeling results into alignment with flow monitoring and outfall data.

Based on design criteria parameters for wastewater generation, inflow and infiltration, gravity pipe capacity, and lift station capacity, we will preprogram up to two (2) sewer model scenarios under existing, near-term and long-term flow conditions.

**Task 4.4 System Capacity Evaluation (TCWD Task 5).** Evaluate the existing and future water and recycled water system, including their ability to meet projected demands.

System capacity evaluations will focus on the following areas:

- » **Supply.** MKN will verify the adequacy of supply to the pressure zones against supply design criteria.
- » **Storage.** MKN will verify the adequacy of storage in each pressure zone against storage design criteria using the summation method. We will compare zone storage capacity to the sum of requirements for operational storage, emergency storage, and fire storage.
- » **Transmission Mains.** MKN will verify efficiency of transmission pipelines under normal operating conditions.
- » **Distribution Mains.** MKN will verify capacity of distribution pipelines to meet customer level of service pressure requirements under normal operating conditions and residual pressure requirements under fire flow conditions.

## 5 TASK GROUP 5 Condition Assessment

**Task 5.1 Condition Assessment (TCWD Task 11).** Review and consolidate asset data for all the TCWD facilities into a centralized asset inventory database to perform a desktop condition assessment of all facilities. Along with the desktop condition assessment, the Consultant shall perform a visual condition assessment (site visits) of the following critical facilities: Barneburg LS, Golf Club LS, Heritage LS, Via Allegre LS, Plano LS/PS, three miles of 16" CML&C discharge pipeline from Dimension Water Treatment Plant (DWTP) to Ridgeline/El toro Pump Station and DWTP, broken up as each site. The Consultant will use information from the desktop and visual condition assessments and industry accepted standards/methods to estimate the remaining useful life of each asset and the cost of replacement.

**Construct Inventory Database.** MKN will develop an inventory database from information provided by the District. We will conduct a gap analysis to verify and validate the quality of the data included in the inventory database and work with the District to acquire additional data or make reasonable assumptions to fill those gaps, as needed. To the extent available, the following data provide a solid basis for a desktop condition assessment: installation year, size, design capacity, efficiency, material, manufacturer, inspection history, maintenance history.

**Inspect Lift Stations (5 locations).** MKN's approach to lift station condition assessments has been proven over completion of 25+ assessments. It includes the following key steps:

1. Review of As-Builts, Develop Standard Review Form
2. Confirmation with District/ Approve Form
3. Conduct Site Inspection: includes (1) Pre-Meeting with Operations to identify key areas of concern and schedule for day, (2) Site Inspection with Mechanical, Electrical/Instrumentation and Structural (3 Engineers total), and (3) Post Meeting to review findings and garner Operations input.
4. Development of Recommendations Summary: this includes projects, justification, concept level cost and priority.

The results will be integrated into the CIP process included as part of Task Group 6.

**Expedite LS Assessment.** To support CIP planning, MKN can expedite the LS Assessment Task (5 locations). The District can use this information to support short term CIP decisions. To assist in supporting the fast tracking of this task, we have provided a sample LS Condition Assessment Form in Appendix A.

**Sewer CCTV – Pipeline (optional).** Based on the outcome of Task 2.4, MKN will sort and rank the CCTV footage by NASSCO PACP Inspection Rating and PACP Quick Rating, then review pipes starting with the highest number of defects and the most severe defects. Projects will be identified, and a program for completing CCTV in other priority areas will be established for inclusion in the CIP process included as part of Task Group 6.

MKN's subconsultant, Downstream Services, recently completed a similar CCTV investigation of a CML&C Steel Pipeline for Three Valleys Water District. The effort delivered a detailed account of where internal liner failure has occurred. CCTV is a prudent first step to understanding the condition of the DWTP transmission main.

**Project Proof.** For Channel Islands Beach CSD, MKN completed a system wide CCTV assessment of sewer pipelines and manholes, and delivered a multi-year CIP plan for repair and replacement.



**Inspect Transmission Pipeline.** MKN has included two elements to the condition assessment associated with the 16-inch DWTP transmission pipeline. This includes a desktop assessment and a field assessment. For the desktop, MKN will review pertinent telemetry data that would reveal whether the pipeline experiences excessive headloss indicating spalling, damage or excessive wear of the lining. We will review maintenance records and discuss performance issues with operators.

For the field assessment, MKN will utilize the services of Downstream Services to conduct a CCTV inspection of the interior. This will require coordination with District operations staff, who will be required to dewater the

pipeline prior to inspection, and provide adequate access points. The CCTV results will be evaluated using NASSCO PACP standards, and the results will be utilized as the foundation for future rehabilitation or replacement efforts identified under Task Group 6 – CIP.

**Life Cycle Cost Analysis.** Based on industry standards and historical failure data provided by the District, MKN will establish the average service life for each asset in the inventory database. We will identify up to two (2) performance indicators for each asset. Based on statistical analysis of age and condition, we will estimate the remaining service life of each component and the year and cost of replacement. We will display year and cost of replacement data on a timeline to assist with the development of renewal programs for critical asset groups. We will estimate Asset Value by applying unit costs developed in Task Group 6 to remaining service life assuming straight-line depreciation (aka Replacement Cost New Less Depreciation or RCNLD).

**Risk Assessment.** As an optional task (not requested in District SOW), MKN will conduct a risk assessment for each asset in the inventory database. Based on our engineering judgment, we will assign a score for Likelihood-of-Failure (LOF) to each asset. We will work with the District to develop an approach to assign a score for Consequence-of-Failure (COF) to each asset. COF tends to be more subjective and should be based on topics of concern to the District such as the number of customers impacted or impact to critical facilities. In the inventory database, we will calculate and normalize the risk associated with each asset as a combination of LOF and COF. This information will assist in project prioritization and may allow for deferral of low-risk projects to reduce capital expenditures

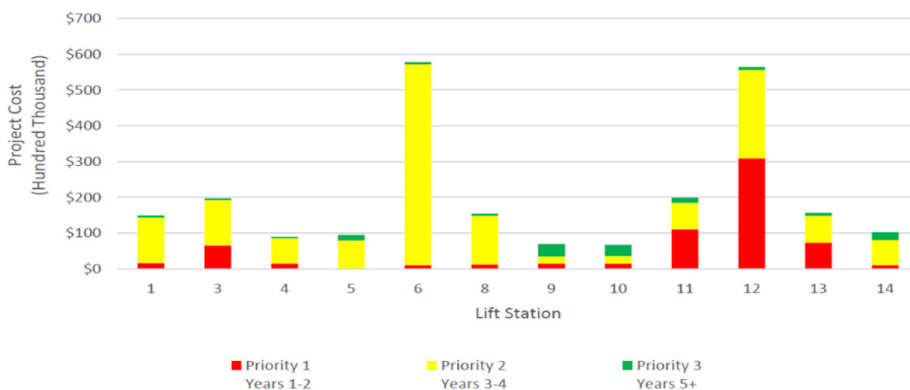

**Project Proof.** For South Coast Water District, MKN completed a condition assessment for 12 lift stations. The results were compiled into priority graphics and a multi-year CIP plan. The same project team and approach is proposed for the District's five (5) lift stations.

## 6 TASK GROUP 6 CIP Development

Recommended SOW:

**Task 6.1 CIP Development (TCWD Task 10).** Recommend system improvements to meet evolving needs, develop capital improvement phasing plans for the water, recycled water, and sewer systems.

MKN will prepare unit costs for the most common project elements from recent construction bids for related work in Orange County. MKN will define typical project cost estimates in terms of labor and materials, administration, engineering, permitting, property acquisition, construction management and contingencies.



MKN's detailed CIP sheets layout a clear path to completion, including planning, design and construction cost estimates and phasing.

MKN will map deficiencies uncovered during supply analysis, hydraulic analysis, condition assessment and risk assessment. We will look for clusters of deficiencies that can be solved with a single project. **We will look for cost-savings opportunities utilizing economies of scale, economies of scope, and synergy between the three systems.**

To facilitate project implementation, MKN will present projects in a clear and comprehensive manner each on a separate sheet including a title, description, justification, cost estimate, map showing project extent, and a discussion of contingencies, risks, grant eligibility, and other critical elements.

MKN will work with the District to develop a methodology for project prioritization. We will prepare a matrix to score and rank projects based on the methodology as a guide for the implementation process.

## 7 TASK GROUP 7 Capacity Charge Methodology

Recommended SOW:

**Task 7.1 Capacity Charge Assessment (TCWD Task 14).** Review the 2020 Water Capacity Charges Update and develop a new methodology for setting these fees charged to developers.

Task Group 7 is dependent on analysis performed in previous Task Group 4 and projects identified in Task Group 6. **We anticipate the need to keep capacity charges in alignment with those imposed by neighboring agencies.** With this in mind, development of the CIP and development of the associated capacity charges as an iterative process is recommended. We will work with the District to strike a balance between CIP implementation and capacity charges that satisfies the District's mission, the needs of the systems, and associated regulatory requirements.

The evaluation of the 2020 Water Capacity Charge Update will be comprehensive and include an analysis as to the reasonableness of the approach and **compliance with nexus requirements pursuant to AB 1600, as codified by California Government Code 66000, et. seq.** To this end, Task Group 7 generally entails the actions listed below.

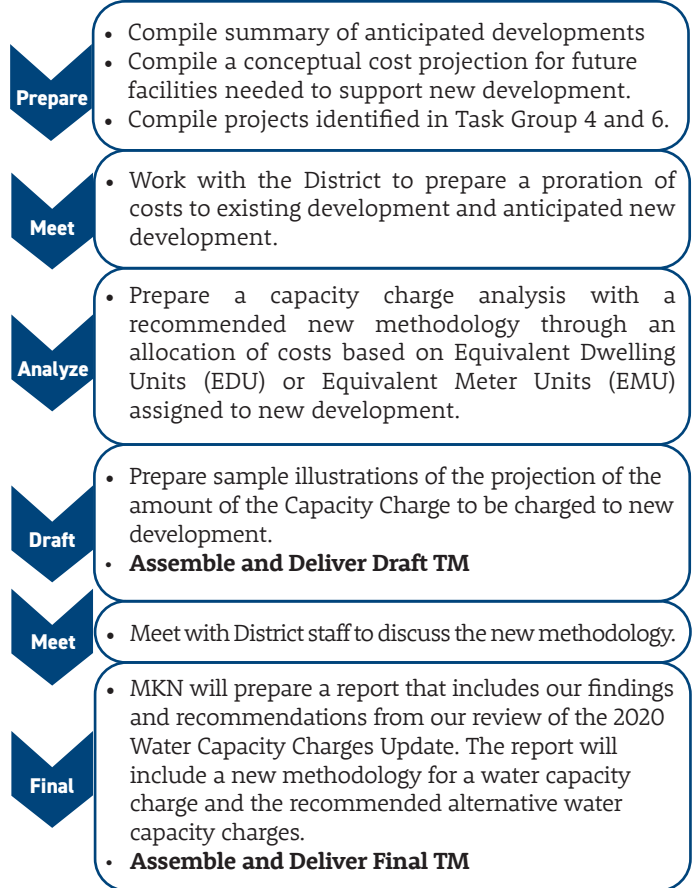

**Task 7.2 Implement the Water Capacity Charge (Optional).** As an optional task, MKN will work with the District to implement the new methodology. We will assist the District in drafting the Proposition 218 Notice requirement and ensure compliance with laws and regulations. We will provide consultation with District staff and legal counsel on the preparation of an Ordinance for a Water Capacity Charge for New Construction. We will facilitate one (1) public outreach meeting to stakeholders to provide expert discussions on the proposed water capacity charge. We will attend up to four (4) staff meetings and two (2) Board Meetings dedicated to present and discuss the implementation process.

MKN's Technical Memorandum approach includes 5 independent deliverables that allows for information to be reviewed in manageable pieces. The final Master Plan will incorporate these efforts into a comprehensive plan. This approach has been proven to keep the process on schedule and minimize impacts on staff time.

MKN will address the District's comments on the Draft Master Plan, prepare and issue the Final Master Plan.

To that end, MKN will engage a cross-section of District staff in a continuous review process aimed at encouraging participation, uncovering and addressing specific needs, accurately interpreting preferences and goals, and ultimately generating buy-in among participants and alignment between the District's mission and implementation of the Master Plan. **Our intent is to help the District create a sense of ownership of the Master Plan through engagement and collaboration.**

MKN views the Master Plan as both a snapshot in time and a living document. It will represent our best understanding of existing and future conditions at the time of submittal, **as well as provide guidance and mechanisms to adapt to changing conditions and unforeseen situations.** We will present our methodologies in sufficient detail to allow for analysis and interpretation of new information when it becomes available. This will facilitate informed decision-making that will ultimately save money, improve the District's position, and optimize the District's limited resources.

**Task 8.2 Report Presentation (TCWD Task 16).** Provide a presentation to District Board on Updated Master Plan and associated work.

MKN will prepare a PowerPoint Presentation of the Master Plan. MKN will present the Master Plan to the Board and discuss next steps. MKN's Project Manager, Tony Herda, and Principal-in-Charge, Ryan Gallagher will lead these efforts. **Tony's unique background as a licensed professional engineer, MBA graduate and experience on 20 Master Plans has been a key factor in his success translating complex master plan processes into distilled and clear executive summaries for elected officials.** In addition, Mr. Gallagher's background as an elected official and Board Member of Orange County Sanitation District will assist Tony in presenting the information in a easily consumable format and respond appropriately to any level of questions that may be presented by the District Board.

The requested level of effort, by staff person, for each task is included in Section 6 - Budget.

## TASK GROUP 8 Report Development

Recommended SOW:

**Task 8.1 Report Preparation (TCWD Task 15).** Provide a complete package of the Updated Master Plan including Executive Summary, Maps and Exhibits for approval and adoption.

The Master Plan has multiple uses and functions. MKN will create a user-friendly reference document tailored to the needs of the District's engineers, operators, and administrators, as well as the needs of key stakeholders such as consultants, regulators, and developers. We will present content in a logical order easily cross-referenced with interactive links, headings and citations. We will present information in an accessible format to assist the reader in understanding its context, value, and applicability to their purpose.

The report will incorporate the previous efforts and will generally consist of the following sections:

- » Executive Summary
- » Chapter 1 - Introduction
- » Chapter 2 - Population and Land Use
- » Chapter 3 - Existing Systems
- » Chapter 4 - Evaluation Criteria
- » Chapter 5 - Flow Analysis
- » Chapter 6 - Hydraulic Model Development
- » Chapter 7 - Water System Analysis
- » Chapter 8 - Reclaimed Water System Analysis
- » Chapter 9 - Wastewater System Analysis
- » Chapter 10 - Capital Improvement Program





# 3 TEAM

PROPOSAL FOR MASTER PLAN AND CONDITION ASSESSMENT STUDY



SECTION 3

# TEAM



**PRINCIPAL-IN-CHARGE**

**PRINCIPAL-IN-CHARGE**

Ryan Gallagher, PE

**PROJECT MANAGEMENT**

**PROJECT MANAGER**

Anthony Herda, PE, MBA

**QA/QC**

**QA/QC MANAGER**

Henry Liang, PE

**MASTER PLANNING**

**HYDRAULIC MODELING**

Rob Lepore, GISP  
Jason Wong, EIT

**CIP AND REPORT DEVELOPMENT**

Anthony Herda, PE, MBA  
Cindy Esparza, EIT

**CAPACITY RATE UPDATE**

Ben Caragan, CPA, MBA

**CONDITION ASSESSMENT**

**LIFT STATION CONDITION ASSESSMENT**

Keenan Bull, PE

**STRUCTURAL**

Joe Wendt, PE<sup>1</sup>

**ELECTRICAL/ INSTRUMENTATION**

Gerry Green, PE<sup>2</sup>

**PIPELINE**

Joseph Reichmuth, PE

**DWTP PIPELINE CCTV**

Downstream Services, Inc.

**SPECIALTY FIELD INVESTIGATIONS**

**SEWER CCTV**

Downstream Services, Inc.

**MANHOLE SURVEY**

Greg Borchard<sup>3</sup>

**FLOW MONITORING**

Downstream Services, Inc.

**MKN Team Highlights:**

- 1. Strong Project Manager.** Local PM, Tony Herda, PE, MBA brings a unique combination of 20+ master plans, business approach and engineering background.
- 2. Modeling Resources.** Tony's extensive modeling experience is further supported by Rob Lepore who has completed 90+ master plans and hydraulic analyses.
- 3. Condition Assessment.** MKN's condition assessment includes NASSCO certified team members and experience on 40 LS condition assessments.
- 4. Capacity Charges.** MKN's Ben Caragan, CPA, MBA has completed similar efforts for public agencies in California.

1 - Petersen Structural Engineers; 2 - Gerry Green, Inc.; 3 - Borchard Surveying and Mapping

## Anthony Herda, PE, MBA - Project Manager, CIP and Report Development

### EDUCATION

Azusa Pacific University,  
Azusa, California

MBA Strategic Planning

California State University,  
Sacramento

BS Civil Engineering

### LICENSES & REGISTRATIONS

California Professional  
Civil - No. C78205

Mr. Herda offers over a decade of experience in water resources engineering planning, specializing in master planning, feasibility studies, hydraulic modeling of water systems, capital planning, urban water management planning, and related multi-disciplinary studies including the preparation of multiple integrated utility master plans. Mr. Herda has prepared **over 20 utility master plans** and has extensive training and experience in constructing, calibrating, and utilizing hydraulic models and asset management programs. He uses these skills in combination with sound engineering practice to optimize return-on-investment for capital expenditures on behalf of his client

## Ryan Gallagher, PE - Principal-in-Charge

### EDUCATION

California Polytechnic State  
University, San Luis Obispo

BS Civil Engineering

### LICENSES & REGISTRATIONS

California Professional Engineer -  
Civil - No. C74805

Over the past 15 years, Ryan has completed over a 100 projects with 25 public agencies in Southern California. **Specific to the District, Ryan brings experience on multiple relevant projects, including the District's Asset Management Procurement, 5 master plans, 15+ hydraulic modeling evaluations, pipeline condition assessments and condition assessment of 25 lift stations.** As an MKN Principal and serving as the Principal-in-Charge for your project, Ryan will ensure that the project meets all expectations of schedule, budget and quality. To that end, he will conduct monthly coordination meetings with our Project Manager, Tony Herda, and ensure that adequate resources are available and that your needs are prioritized.

## Henry Liang, PE - QA/QC Manager

### EDUCATION

California State University, Fresno  
Masters of Business  
Administration

University of California, Berkeley  
BS Civil and Environmental  
Engineering

### LICENSES & REGISTRATIONS

California Professional Engineer -  
Civil - No. C68442

Mr. Liang is a Principal with over 16 years of experience in planning and design of municipal water, wastewater and water resources projects ranging from planning to design of major transmission pipelines, pump stations, and wells including raw and treated water projects throughout California. He has extensive experience in water, wastewater, and water resources projects ranging from planning to design of municipal water systems, wastewater collection systems, transmission pipelines, pump stations, and wells. His expertise includes detailed hydraulic modeling and transient analysis for a variety of water and wastewater systems and development of comprehensive infrastructure master plans. **He has completed 20+ master plans throughout his career and recently completed the integrated master plan for South Coast Water District.**

## Keenan Bull, PE - Lift Station Condition Assessment

### EDUCATION

Missouri University of Science and  
Technology

MS Civil Engineering

BS Civil Engineering

### LICENSES & REGISTRATIONS

California Professional Engineer -  
Civil - No. C91138

Keenan Bull has over 19 years of experience in civil engineering as a design engineer and project manager for private and municipal water and wastewater treatment operations, water distribution systems, wastewater collection systems, large-diameter pipelines, water conveyance systems, and water storage facilities. Keenan's expertise in lift stations covers a broad range of constructability reviews, planning, design and condition inspections. **Specific to the District, Keenan has led the mechanical inspection for condition assessment of 25 lift stations and participated in the design review of 6 lift or pump stations in the past 12 months alone.**

## Rob Lepore, GISP - Hydraulic Modeling

### EDUCATION

Wentworth Institute of Technology  
Boston, MA

BS Environmental Engineering

### LICENSES & REGISTRATIONS

AWWA Utility Risk & Resilience  
Certificate Program

CA-NV AWWA Certified Water  
Audit Validator

Certified Geographic Information  
System Professional (GISP)

Mr. Lepore has 20 years of experience in developing comprehensive water, wastewater, and recycled water master plans for public utilities with a focus on GIS integration. **Rob has served as a project manager or Water Resource Planner for more than 95 master planning and hydraulic modeling projects in central and southern California. In addition, Rob has prepared 14 Urban Water Management Plans and completed over 50 GIS implementation projects.** He is also a Geographic Information System Professional (GISP) certified by the GIS Certification Institute. Rob has worked for a public utility, GIS consulting firm, and multiple engineering firms, which has allowed him to focus and refine his execution of critical master planning projects for our municipal infrastructure clients.

## Jason Wong, EIT - Hydraulic Modeling

### EDUCATION

University of the Pacific, Stockton,  
CA

BS Civil Engineering  
MS Civil and Environmental  
Engineering

### CERTIFICATIONS

EIT Certified #163157

Jason's project experience includes planning and design of water and wastewater systems and facilities. Mr. Wong has experience with water supply and wastewater generation analysis, hydraulic modeling, design of water and wastewater infrastructure, and risk assessments. **Jason is proficient in ESRI ArcGIS, EPANET, Innovyze InfoWater and InfoSewer, Bentley WaterCAD, SewerCAD, SewerGEMS, and PCSWWM.**

## Joseph Reichmuth, PE - Pipeline Condition Assessment

### EDUCATION

California Polytechnic State  
University, San Luis Obispo

BS Civil Engineering

### LICENSES & REGISTRATIONS

California Professional Engineer -  
Civil - No. C63124

Mr. Reichmuth brings 20 years of design and field engineering experience with an emphasis in pipeline design, ranging from condition assessment and rehabilitation to planning and design. Pipeline experience includes various rehabilitation and trenchless construction methods, such as horizontal directional drilling and jack-and-bore, and pipeline sizes up to 42-inches. **Mr. Reichmuth is certified for NASSCO ITCP – Cured In Place Pipe and Manhole Rehabilitation,** and has leveraged this experience to complete multiple pipeline assessments and rehabilitation projects, from planning through design.

## Ben Caragan, CPA, MBA - Capacity Rate Update

### EDUCATION

University of California, Riverside  
MBA Business Administration

BS Biology

### LICENSES & REGISTRATIONS

Certified Public Accountant,  
California Board of Accountancy,  
126515

Mr. Caragan is an experienced finance and accounting consultant with more than 20 years of experience specializing in financial advisory and works with public agencies that include cities and water districts. His areas of expertise include utility performance evaluations, cost-of-service studies, budgetary preparation, financial statement analysis, financial reporting, preparation of proforma financial statements, fee studies, and management accounting and auditing. He has prepared financial performance and operational audits using analytical procedure components pursuant to auditing standards. Mr. Caragan has also served as the financial advisor to various public agencies in the funding of capital improvements, which included private placements and bond issues in multiple series.



# 4 EXPERIENCE AND REFERENCES

PROPOSAL FOR MASTER PLAN AND CONDITION ASSESSMENT STUDY



## SECTION 4

# EXPERIENCE AND REFERENCES

What makes this Master Plan update unique is reviewing multiple systems for the same client at the same time in an integrated fashion. The MKN Team has prepared numerous integrated master plans and similar efforts that coordinate planning across multiple systems. We have selected examples and references that demonstrate integrated master planning.

## Water and Sewer Master Plan

**OWNER:** Heber Public Utility District  
**KEY PERSONNEL:** Anthony Herda, PE, Project Manager  
**DURATION:** 2020  
**CLIENT CONTACT:**  
Laura Fischer, General Manager  
lfischer@heber.ca.gov  
760-336-1572

### RELEVANCE TO TRABUCO CANYON:

1. Sewer and water model development.
2. Combined capacity analysis and performance analysis CIP developed to streamline rate study and grant applications

### BRIEF DESCRIPTION

Development and calibration of a water and a sewer system hydraulic models for HPUD to assist with determination of hydraulic capacity deficiencies under existing and future conditions. Conducted facility inspections of the HPUD Water and Wastewater Treatment Plants to gather information on performance and capacity deficiencies of existing equipment. Prepared an integrated master plan documenting recommended improvement to address existing conditions and near-term conditions assuming reasonable growth. **The master plan was specifically designed to facilitate a rate study and grant funding applications.**

## Water and Sewer Master Plan

**OWNER:** Channel Islands Beach Community Services District  
**KEY PERSONNEL:** Keenan Bull, PE, Senior Engineer; Rob Lepore, GISP, Water Resource Planner; Anthony Herda, PE, MBA; Ryan Gallagher, PE; Jason Wong, EIT; Cindy Esparza, EIT  
**DURATION:** November 2020 to June 2021  
**CLIENT CONTACT:**  
Pete Martinez, General Manager  
353 Santa Monica Drive  
Oxnard, CA 93035  
805.827.3000  
pmartinez@cibcsd.com

### RELEVANCE TO TRABUCO CANYON:

1. Integrated Master Plan
2. Condition assessments (7 LS)
4. Updating and calibrating existing hydraulic models

### BRIEF DESCRIPTION

MKN completed a Water and Sewer Master Plan for Channel Islands Beach Community Services District, which included updating existing hydraulic models; capacity analysis of the water and sewer systems; condition assessment of pump stations, pipelines and manholes; and establishing a 5-year capital improvement plan (CIP) in close coordination with District operations and management team.

Under a previous contract, and in support of the planning efforts, MKN completed a condition assessment of seven (7) District lift stations. Utilizing the results of these efforts, **MKN identified a cost saving solution for a lift station improvement project that leveraged a regional partner (City of Oxnard) to reduce financial impacts to the District (approximately \$200,000).**

# Water and Sewer Systems Modeling, Planning, and Fee Studies Update

**OWNER:** City of Tehachapi

**KEY PERSONNEL:** Rob Lepore, Water Resource Planner; Henry Liang, PE

**DURATION:** May 2018 – October 2019

**CLIENT CONTACT:**

Jay Schlosser, PE  
661.822.2200 Ext. 115  
jschlosser@tehachapicityhall.com

**RELEVANCE TO TRABUCO CANYON:**

1. Capacity study update.
2. Integrated Master Plan

## BRIEF DESCRIPTION

MKN prepared a comprehensive update to the water and sewer models and master plans that included: Identifying operational improvements that are needed now, identifying improvements that will be needed as growth continues (over a 20-year planning horizon), **providing the linkage required to revise connection/mitigation fee**, providing operational guidance for system operation and maintenance activities such as flushing, developing an updated and more detailed water distribution and sewer collection systems atlas maps.

# Water and Sewer Master Plan

**OWNER:** City of Grover Beach

**KEY PERSONNEL:** Rob Lepore, GISP; Water Resources Planner, Joseph Reichmuth, PE

**DURATION/KEY MILESTONES:** June 2019 - April 2020

**CLIENT CONTACT:**

Erin Wiggin, CIP Project Manager  
154 South Eighth Street  
Grover Beach, CA 93433  
805.473.4537

**RELEVANCE TO TRABUCO CANYON:**

1. Integrated master planning effort.
2. Hydraulic model development.

## BRIEF DESCRIPTION

Evaluation of existing water production, storage, and distribution facilities; creation of a GIS-based hydraulic water model; review of water quality requirements and goals; development of the City's water supply portfolio; evaluation of wastewater collection system and lift stations; creation of GIS-based hydraulic sewer model; identification of deficiencies under existing and future conditions; and **development of Capital Improvements Program (CIP) and cost opinions for existing and future improvements.**

# Infrastructure Master Plan (Water, Sewer, and Recycled)

**OWNER:** South Coast Water District

**KEY PERSONNEL:** Henry Liang, PE

**CLIENT CONTACT:**

Taryn Kjolsing, Principal  
949.541.1327  
tkjolsing@scwd.org

**RELEVANCE TO TRABUCO CANYON:**

1. Integrated approach to master planning analysis and solutions.

## BRIEF DESCRIPTION

MKN & Associates teamed with AECOM to perform the **water, recycled water, and sewer infrastructure master plan updates** for the South Coast Water District. The updated master planning effort focused on identifying potential local source development options, changes in the District's physical infrastructure due to redevelopment, changes in water demand, wastewater generation, and recycled water use, analysis of demand patterns provided from the District's SCADA system and water meter records, and identify new sources of supply into the water system.

# Water Master Plan

**OWNER:** City of Ventura

**KEY PERSONNEL:** Henry Liang, PE; Rob Lepore, GISP; Anthony Herda, PE, MBA

**DURATION:** November 2020 - January 2022 (Projected)

**CLIENT CONTACT:**

Adam Bugielski, PE, Principal Civil Engineer  
 abugielski@cityofventura.ca.gov  
 805.652.4518

**RELEVANCE TO TRABUCO CANYON:**

1. Updated existing hydraulic model.
2. Combined capacity analysis and performance analysis
3. Capital Planning

**BRIEF DESCRIPTION**

MKN is preparing the City’s 2021 Water Master Plan Update. The Update includes integrating existing and future land use changes from the City’s current General Plan update, converting the hydraulic model from Innovyze Infowater to Bentley WaterCAD, developing/implementing new demand peaking factors and diurnal curves, updating analysis criteria, updating the hydraulic model, analyzing the water distribution system, conducting a condition assessment of the City’s major water treatment and distribution facilities, and **developing recommendations for future improvements to be incorporated into the City’s capital improvement program.**

MKN’s Team has Delivered 40+ Master Plans. A sampling of additional relevant Master Plan projects are noted in the following table.

Project	Client	Service	Master Plan	Alternatives Analysis	Hydraulic Modeling	Condition Assessment	CIP
Water Master Plan (2015)	Arcadia	W	✓	✓	✓	✓	✓
Water Master Plan (2018)	Grover Beach	W	✓	✓	✓	✓	✓
Water Master Plan (2015)	Monrovia	W	✓	✓	✓	✓	✓
Water Master Plan (2013)	SCVWA/CLWA	W	✓	✓	✓	✓	✓
Water Master Plan (2008)	SCVWA/CLWA	W	✓	✓	✓	✓	✓
Water Master Plan (2011)	La Habra Heights CWD	W	✓	✓	✓	✓	✓
Water Master Plan (2013)	Valley County WD	W	✓	✓	✓	✓	✓
Sewer Model Report (2019)	Tehachapi	WW	✓	✓	✓		✓
Collection Master Plan (2013)	Nipomo CSD	WW	✓	✓	✓		✓
Water Master Plan (2017)	Valley Children's Hospital	W	✓	✓	✓	✓	
Water Master Plan Update (2012)	La Verne	W	✓	✓	✓		✓
Pinetop-Lakeside Master Plan (2014)	AZ Water Co.	W	✓		✓	✓	✓
Water Master Plan (2019)	HI County Dept. of WS	W	✓		✓	✓	✓
Sewer Master Plan (2019)	Arvin	WW	✓		✓	✓	✓
Reclaimed Water Master Plan (2018)	Corona	RW	✓	✓	✓		✓
Water Master Plan (2021)	East Niles CSD	W	✓	✓	✓		
Water Master Plan (2014)	Sunny Slope Water Co.	W	✓		✓	✓	✓
Recycled Water Master Plan (2009)	Oxnard	RW	✓	✓	✓		✓

# Water Rate and Capacity Charge Studies

**OWNER:** City of Inglewood

**KEY PERSONNEL:** Ben Caragan, CPA

**CLIENT CONTACT:**

Louis Atwell, PE | Director of Public Works  
 City of Inglewood  
 One Manchester Boulevard  
 Inglewood, CA 90301  
 latwell@cityofinglewood.org  
 310.412.5333

## BRIEF DESCRIPTION

Prepared a water, reclaimed water, sewer rate studies for the City. Currently preparing the City's **water capacity charge for new development** and redevelopment of Hollywood Park. Entailed review of water consumption, water master plans, and other economic data to establish water capacity charges. Established fixed and variable charges according to AWWA rate-setting standards. Rates were established to ensure cost recovery.

**OWNER:** City of Beverly Hills

**KEY PERSONNEL:** Ben Caragan, CPA

**CLIENT CONTACT:**

Vince Damasse, PE | Water Resources Manager  
 City of Beverly Hills  
 345 Foothill Road  
 Beverly Hills, CA 90210  
 vdamasse@beverlyhills.org  
 310.285.2491

## BRIEF DESCRIPTION

**Established the City's water supply exaction fee for new development.** The fee encompassed the City's service area and a portion of West Hollywood. The fee assesses both new construction and substantial remodels and additions for residential, commercial and mixed-used projects for the development of local groundwater and non-potable water supplies.

MKN's Ben Caragan, CPA, MBA has prepared over a dozen rate studies, capacity charge studies and analyses of financial condition.

Agency Client	Rate Study	Capacity Charge Study	Financial Condition Analysis
City of Beverly Hills		✓	
South Montebello Irrigation District	✓	✓	✓
Pico Water District	✓	✓	✓
South Placer Wastewater Authority		✓	
South Placer Municipal Utility District		✓	
Marina Coast Water District		✓	
City of Inglewood	✓		
City of San Carlos		✓	
City of Santa Ana	✓		
Castaic Lake Water Agency			✓
Newhall County Water District			✓
City of Montebello	✓		
City of Bellflower	✓		
City of Norwalk	✓		✓
City of Sierra Madre	✓		
City of Victorville		✓	
Farm Mutual Water Company	✓		

MKN Team brings experience on over 60 Lift Stations, this includes 20 design projects and 40 condition assessments.

## Lift Station Condition Assessment (12 lift stations)

### Various Cities in South Orange County, CA

**OWNER:** South Coast Water District

**KEY PERSONNEL:** Ryan Gallagher, PE, Project Manager; Keenan Bull, PE, Condition Assessment; Joseph Reichmuth, PE, Technical Advisor; Gerry Green, PE, Electrical; Joe Wendt, PE, Structural

**DURATION:** February 2021 - July 2021

**CLIENT CONTACT:**

Taryn Kjolsing, Principal  
949.541.1327  
tkjolsing@scwd.org

#### BRIEF DESCRIPTION

Developed standard condition assessment form for lift stations and **performed field assessment of twelve (12) lift stations** for South Coast Water District. Evaluated wet well capacity, pump efficiency and operator interviews. Delivered detailed field inspection results and condition ratings for all lift stations and integrated into online ArcGIS platform. Provided report with over 160 recommendations and a 10 year CIP for implementation based on a priority ranking system.

#### RELEVANCE TO TRABUCO CANYON:

1. Lift Station Inspection
2. Full disciplines
3. Operator coordination

## Lift Station Condition Assessment (7 Lift Stations)

### Laguna Beach, CA

**OWNER:** Emerald Bay Service District

**KEY PERSONNEL:** Ryan Gallagher, PE, Project Manager; Keenan Bull, PE, Condition Assessment; Joseph Reichmuth, PE, Technical Advisor; Gerry Green, PE, Electrical

**DURATION:** March 2021 to June 2021

**CLIENT CONTACT:**

Mike Dunbar | General Manager  
949.533.4052  
mdunbar@ebservicedistrict.com

#### BRIEF DESCRIPTION

Developed standard condition assessment form for lift stations and performed field assessment of seven (7) lift stations for Emerald Bay Service District. Effort included collaboration with District Operators, and resulted in recommendation of 47 projects/improvements across all lift stations for a total of \$2.1M. Projects were prioritized over a 5 year implementation period.

#### RELEVANCE TO TRABUCO CANYON:

1. Lift Station Inspection
2. Full disciplines
3. Operator coordination





# 5 SCHEDULE

PROPOSAL FOR MASTER PLAN AND CONDITION ASSESSMENT STUDY



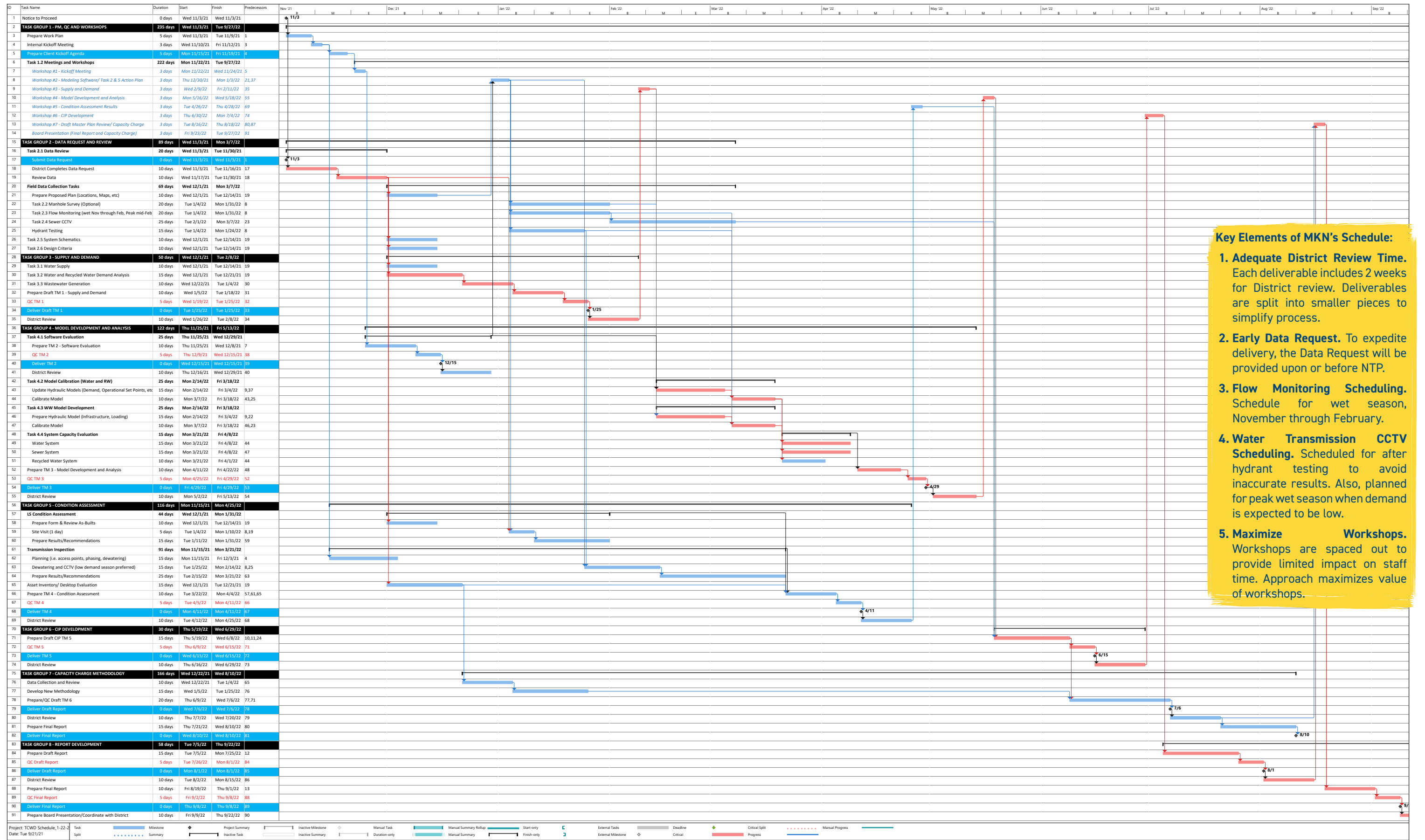

- Key Elements of MKN's Schedule:**
- Adequate District Review Time.** Each deliverable includes 2 weeks for District review. Deliverables are split into smaller pieces to simplify process.
  - Early Data Request.** To expedite delivery, the Data Request will be provided upon or before NTP.
  - Flow Monitoring Scheduling.** Schedule for wet season, November through February.
  - Water Transmission CCTV Scheduling.** Scheduled for after hydrant testing to avoid inaccurate results. Also, planned for peak wet season when demand is expected to be low.
  - Maximize Workshops.** Workshops are spaced out to provide limited impact on staff time. Approach maximizes value of workshops.





# 6 BUDGET

PROPOSAL FOR MASTER PLAN AND CONDITION ASSESSMENT STUDY



**Trabuco Canyon Water District  
Master Plan and Condition Assessment Study (Project No. 2122-012)**

	Principal Engineer (RPG, HL)	Principal Engineer (JR)	Principal Planner (AH)	Senior Project Engineer (BC)	Senior Project Engineer (KB)	Sr. Water Resources Planner (RL)	Assistant Engineer II (JW)	Assistant Engineer II (CE)	Supervising Drafter/GIS (JF)	Structural - PSE (Sub)	Electrical/Instr.- GGI (Sub)	Total Hours (MKN)
<b>Task Group 1: Project Management, Quality Control, and Workshops</b>												
<b>Task 1.1 Project Management (11 months)</b>	22		44				11					77
<b>Task 1.2 Meetings and Workshops</b>	14	4	20	10	4	10	28	0	0	0	0	90
<i>Workshop #1 (Kickoff Meeting)</i>	2	2	8	2		2	4					20
<i>Workshop #2 (Model, Software, Field Data Collection)</i>	2		2		2	2	4					12
<i>Workshop #3 (Supply and Demand)</i>	2		2			2	4					10
<i>Workshop #4 (Modeling Review)</i>	2		2			2	4					10
<i>Workshop #5 (Condition Assessment)</i>	2	2	2		2		4					12
<i>Workshop #6 (CIP Development)</i>	2		2				4					8
<i>Workshop #7 (Draft Report/Capacity Charges)</i>	2		2	8		2	4					18
<b>Task 1.3 Quality Control (7 deliverables; 5 hrs/per)</b>	35											35
<b>Subtotal</b>	<b>71</b>	<b>4</b>	<b>64</b>	<b>10</b>	<b>4</b>	<b>10</b>	<b>39</b>	<b>0</b>	<b>0</b>	<b>0</b>	<b>0</b>	<b>202</b>
<b>Task Group 2: Data Request and Review</b>												
<b>Task 2.1 Data Review (TCWD Task 1)</b>			16		8	16	24					64
<b>Task 2.3 Flow Monitoring (TCWD Task 8) - Dry wthr, 5 mtrs/ 7 days</b>			4			8	24					36
<b>Task 2.5 System Schematics (TCWD Task 12) - 1 int./3 system/2 HGL</b>			8			4	12		12			36
<b>Task 2.6 Design Criteria (TCWD Task 13)</b>			6			12	4					22
<b>Subtotal</b>	<b>0</b>	<b>0</b>	<b>34</b>	<b>0</b>	<b>8</b>	<b>40</b>	<b>64</b>	<b>0</b>	<b>12</b>	<b>0</b>	<b>0</b>	<b>158</b>
<b>Task Group 3: Supply and Demand</b>												
<b>Task 3.1 Water Supply (TCWD Task 2)</b>	2		24			8		30				64
<b>Task 3.2 Water &amp; Recycled Water Demand Analysis</b>	2		8			30		40				80
<b>Task 3.3 Wastewater Generation</b>	2		8			16	32					58
<b>Subtotal</b>	<b>6</b>	<b>0</b>	<b>40</b>	<b>0</b>	<b>0</b>	<b>54</b>	<b>32</b>	<b>70</b>	<b>0</b>	<b>0</b>	<b>0</b>	<b>202</b>
<b>Task Group 4: Model Development</b>												
<b>Task 4.1 Software Evaluation (TCWD Task 3)</b>	1		6			4	16					27
<b>Task 4.2 Model Calibration (TCWD Task 4) -W/RW</b>	4	0	28	0	0	40	40	40	0	0	0	152
<i>Hydrant Testing (2 days) - plan, form, and site observation</i>			8			8		16				32
<i>Water Model Calibration</i>	2		12			16	40					70
<i>RW Model Calibration</i>	2		8			16		24				50
<b>Task 4.3 Model Development (TCWD Task 6) - WW</b>	2		24			40	80					146
<b>Task 4.4 System Capacity Evaluation (TCWD Task 5) - W/RW/WW</b>	2		16			40	24	8	8			98
<b>Subtotal</b>	<b>9</b>	<b>0</b>	<b>74</b>	<b>0</b>	<b>0</b>	<b>124</b>	<b>160</b>	<b>48</b>	<b>8</b>	<b>0</b>	<b>0</b>	<b>423</b>
<b>Task Group 5: Condition Assessment</b>												
<b>Task 5.1 Condition Assessment (TCWD Task 11)</b>	0	42	22	0	66	36	0	120	12	55	24	377
<i>Construct Inventory Database</i>		2	12		8	24		32	8			86
<i>Inspect Lift Stations (5 locations)</i>		24			30			32	4	55	24	169
<i>Inspect Transmission Pipeline</i>		16	4		24			24				68
<i>Life Cycle Cost Analysis</i>			6		4	12		32				54
<b>Subtotal</b>	<b>0</b>	<b>42</b>	<b>22</b>	<b>0</b>	<b>66</b>	<b>36</b>	<b>0</b>	<b>120</b>	<b>12</b>	<b>55</b>	<b>24</b>	<b>377</b>
<b>Task Group 6: CIP Development</b>												
<b>Task 6.1 CIP Development (TCWD Task 10) - W/RW/WW</b>	4	4	24		32	36	40		16			156
<b>Subtotal</b>	<b>4</b>	<b>4</b>	<b>24</b>	<b>0</b>	<b>32</b>	<b>36</b>	<b>40</b>	<b>0</b>	<b>16</b>	<b>0</b>	<b>0</b>	<b>156</b>
<b>Task Group 7: Capacity Change Methodology</b>												
<b>Task 7.1 Capacity Charge Assessment (TCWD Task 14)</b>	2	0	12	120	8	0	12	0	0	0	0	154
<i>Data Collection and Review</i>				32			6					38
<i>Valuation of System (Utilize Inventory from Task 5.1)</i>			4		8							12
<i>Develop New Water Capacity Charge Methodology</i>			6	50								56
<i>Prepare Report (Draft/Final)</i>	2		2	38			6					48
<b>Subtotal</b>	<b>2</b>	<b>0</b>	<b>12</b>	<b>120</b>	<b>8</b>	<b>0</b>	<b>12</b>	<b>0</b>	<b>0</b>	<b>0</b>	<b>0</b>	<b>154</b>
<b>Task Group 8: Report Development</b>												
<b>Task 8.1 Report Preparation (TCWD Task 15) - Draft/Final</b>	4	4	16		16	45	32	24	8			149
<b>Task 8.2 Report Presentation (TCWD Task 16)</b>	8		12				8					28
<b>Subtotal</b>	<b>12</b>	<b>4</b>	<b>28</b>	<b>0</b>	<b>16</b>	<b>45</b>	<b>40</b>	<b>24</b>	<b>8</b>	<b>0</b>	<b>0</b>	<b>177</b>
<b>TOTAL BUDGET</b>	<b>104</b>	<b>54</b>	<b>298</b>	<b>130</b>	<b>134</b>	<b>345</b>	<b>387</b>	<b>262</b>	<b>56</b>	<b>55</b>	<b>24</b>	<b>1849</b>
<b>Task Group 9: Optional Scope</b>												
<b>Task 2.2 Manhole Survey (TCWD Task 7) - 300 manholes</b>	2		8			8		24				42
<b>Task 2.3A Wet Wthr Flow Mntg. (5 Locations) - add to Task 2.3</b>	2		4			8	20					34
<b>Task 2.4 CCTV (TCWD Task 9) - assume 23,000 feet</b>	2				8	8	16		8			42
<b>Task 2.5 Traffic Control 3-man crew/day (cost per day, if required)</b>			2									2
<b>Task 5.2 Risk Assessment</b>	2		16		4			22	8			52
<b>Task 7.2 Implement Water Capacity Charge</b>	2		6	12				16				36
<b>TOTAL OPTIONAL BUDGET</b>	<b>10</b>	<b>0</b>	<b>36</b>	<b>12</b>	<b>12</b>	<b>24</b>	<b>36</b>	<b>62</b>	<b>16</b>	<b>0</b>	<b>0</b>	<b>208</b>





# 7 APPENDIX A

PROPOSAL FOR MASTER PLAN AND CONDITION ASSESSMENT STUDY



## TABLE OF CONTENTS

1. Data Request
2. Lift Station Inspection Form
3. CCTV for Potable CML&C Steel Pipeline
4. Integrated Master Plan Report Outline
5. Water System Schematic
6. Harris Grade Pressure Zone Hydraulic Profile
7. Deliverables Summary
8. Scope Assumptions

**Trabuco Canyon Water District  
Water, Reclaimed Water and Wastewater Master Plan Update**



Reference	Description	Purpose	Responsible Party	Comments
<b>Chapter 1 Introduction</b>	General/Specific Plans	Review	MKN	Publicly Available
	Other Land Use Planning Documents	Review	MKN	Publicly Available
	Water System Operating Permit	Compliance and Constraints	District	
	Agreements with Other Agencies	Compliance and Constraints	District	
	2020 Urban Water Management Plan	Consistency	MKN	Publicly Available
	Strategic Plan	Consistency	District	
	District Policies and Procedures	Consistency	MKN	Available on District Website
	District Programs (maintenance, conservation, renewal, etc.)	Consistency	MKN	Available on District Website
	District Service Area Boundary Map	Study Area	MKN	Available from LAFCo
	District Sphere of Influence Map	Study Area	MKN	Available from LAFCo
Current Master Plans	Review	MKN	Publicly Available	
<b>Chapter 2 Population and Land Use</b>	Authoritative Population Estimate	Population Projection	District	
	US Census Data	Population Projection	MKN	Publicly Available
	Land Use/Parcel GIS Data	Land Use Analysis	MKN	Publicly Available
	Known Development Projects	Land Use Analysis	District	
<b>Chapter 3 Existing Systems</b>	Water System GIS Data	Existing Infrastructure	District	
	As-builts for infrastructure not included in GIS	Existing Infrastructure	District	
	Supply Source Information	Existing Supply	District	
	Water System Inventory	Existing Infrastructure	District	
	Description of Water Facilities	Functionality	District	
	Water Pressure Zone Boundaries	System Organization	District	
	Information on new pressure zone development	System Organization	District	
	Reclaimed Water System GIS Data	Existing Infrastructure	District	
	As-builts for infrastructure not included in GIS	Existing Infrastructure	District	
	Reclaimed Water System Inventory	Existing Infrastructure	District	
<b>Chapter 4 Evaluation Criteria</b>	Description of Reclaimed Water Facilities	Functionality	District	
	Reclaimed Water Pressure Zone Boundaries	System Organization	District	
	Design Standards	Level of Service	District	
	Construction Standards and Standard Drawings	Level of Service	District	
<b>Chapter 5 Flow Analysis</b>	Asset Management/Life Cycle Cost Data	Condition Assessment	District	
	Operating Plans and Manuals	Level of Service	District	
	Water Billing Records	Demand Analysis	District	
	Water Production Records	Demand Analysis	District	
	Water Distribution System SCADA Data	Demand Analysis	District	
	Reclaimed Water Billing Records	Demand Analysis	District	
	Reclaimed Water Effluent Records	Demand Analysis	District	
	Supplemental Reclaimed Water Deliveries	Demand Analysis	District	
	Reclaimed Water Distribution System SCADA Data	Demand Analysis	District	
	Wastewater Influent Records	Generation Analysis	District	
<b>Chapter 6 Hydraulic Model Development</b>	Lift Station SCADA Data	Generation Analysis	District	
	Historical Meteorological Data	Generation Analysis	MKN	Publicly Available
	Existing Water Model	Hydraulic Analysis	District	
	Water Facility Operational Settings	Hydraulic Analysis	District	
	Existing Reclaimed Water Model	Hydraulic Analysis	District	
	Reclaimed Water Facility Operational Settings	Hydraulic Analysis	District	
<b>Chapter 7 Water System Analysis</b>	Recent Pump Efficiency Tests	Hydraulic Analysis	District	
	Lift Station Settings	Hydraulic Analysis	District	
	Recent Pump Efficiency Tests	Hydraulic Analysis	District	
	Planned Water Projects	Validation	District	
<b>Chapter 8 Reclaimed Water System Analysis</b>	Known Water System Deficiencies and Challenges	Area of Focus	District	
	Water System Maintenance Records	Condition Assessment	District	
	Water System Facility Inspection Reports	Condition Assessment	District	
<b>Chapter 9 Wastewater System Analysis</b>	Planned Reclaimed Water Projects	Validation	District	
	Known Reclaimed Water System Deficiencies and Challenges	Area of Focus	District	
	Reclaimed Water System Maintenance Records	Condition Assessment	District	
	Reclaimed Water System Facility Inspection Reports	Condition Assessment	District	
<b>Chapter 10 Capital Improvement Program</b>	Planned Sewer Projects	Validation	District	External Research
	Known Sewer System Deficiencies, Challenges, Hotspots	Area of Focus	District	
	Sewer System Maintenance Records	Condition Assessment	District	
	List Station Inspection Reports	Condition Assessment	District	
<b>Chapter 11 Methods of Finance</b>	Recent CIP Bid Documents	Cost Assumptions	MKN	External Research
	Developer Agreements	Cost Assumptions	District	
<b>Chapter 11 Methods of Finance</b>	Historical Financial Statements	Financial Review	MKN	Available on District Website
	Current Capacity Charge and Rate Studies	Financial Review	MKN	Available on District Website



**TRABUCO CANYON WATER DISTRICT  
LIFT STATION CONDITION ASSESSMENT FORM**

**FACILITY AND REVIEWING INFORMATION**

Date/Time of Assessment:
Site Name/ Facility ID:
Assessor Name:

GENERAL			
GENERAL INFORMATION (MKN)	FIELD DATA	RATING	REVIEWER COMMENTS
Year originally constructed			
As-builts available?	Yes/No		
Submerged Pumps or Dry Pit?	Submerged/Dry		
SAFETY FEATURES (MKN)	FIELD DATA	RATING	REVIEWER COMMENTS
Fencing			
Hatch lock			
Security system, gate or intrusion alarm			
Fall protection / Safety			
Pump removal lifting equipment			
Ventilation (confined space areas)			
Safety ladder/ Stairs			
Handrails for dry pits			
SITE ACCESS/FEATURES (MKN)	FIELD DATA	RATING	REVIEWER COMMENTS
Site Grading			
Site Access (Road, Gates, etc.)			
Space for Maintenance Activities			
Surface Improvements (landscape, bollards, etc.)			

STRUCTURES			
GENERAL - WET WELL (MKN)	FIELD DATA	RATING	REVIEWER COMMENTS
Shape			
Dimensions			
Wet Well Hatch Opening Size			
Overflow Level			
Year of Wet Well Lining (if applicable)			
Lining Condition (if applicable)			
Concrete or rebar exposed?			
Is grease build up visible (FOG)?			
Odor control system/Vent Size			
# of odor complaints in past 12 months?			
Evidence of high water levels?			
GENERAL - DRY WELL (MKN)	FIELD DATA	RATING	REVIEWER COMMENTS
Shape			
Dimensions			
Space for Maintenance Activities			
Sump Pump			
STRUCTURAL EVALUATION (PSE)	FIELD DATA	RATING	REVIEWER COMMENTS
Roof			
Exterior Walls			
Interior Walls			
Floor/Slab			
Windows/Openings			
Doors			
Pipe Supports			
Large Equipment Anchorage (Generators, Pumps, etc.)			
Platforms (if present)			
Access hatch			



MECHANICAL			
GENERAL - PUMP INFORMATION (MKN)	FIELD DATA PUMP (1/2/3)	RATING	REVIEWER COMMENTS
Design/Field Capacity (gpm)	X/X/X		
Model	X/X/X		
Manufacturer	X/X/X		
Pump Configuration	X/X/X		
Year Installed	X/X/X		
Level settings (On/Off)	X/X/X		
Speed Settings	X/X/X		
Clogging/Ragging issues?	X/X/X		
Overheating issues?	X/X/X		
Excessive noise?	X/X/X		
Leaking or seal failures?	X/X/X		
MECHANICAL (MKN)	FIELD DATA	RATING	REVIEWER COMMENTS
Pump Condition	X/X/X		
Pressure Gauges			
Valves			
Piping			

ELECTRICAL/INSTRUMENTATION			
GENERAL (GG)	FIELD DATA	RATING	REVIEWER COMMENTS
PLC Controller present (install year and condition)			
Permanent Back up Power? Type & Rating			If no, is connection available?
Type of level sensor			
List remote alarms			
List local annunciation alarms			
Manual or automatic transfer switch			
ELECTRICAL SAFETY (GG)	FIELD DATA	RATING	REVIEWER COMMENTS
Hazardous rating for outlets?			
Automatic exhaust fan (NFPA 820 requirements)?			
Explosion proof seals at conduit penetrations?			
Arc-flash labeling?			
ELECTRICAL EVALUATION (GG)	FIELD DATA	RATING	REVIEWER COMMENTS
Flowmeter (if applicable)			
Level Sensor			
Ventilation			
Lighting			
Generator (if applicable)			
Transfer Switch			
Main Electrical Panel			
Motor Control Center			
Pump Motor			
Communications			
PLC Controller			



**Left Plot with Images**

<b>Client</b> Three Valleys Water...	<b>City</b> Claremont	<b>Street</b> Base Line Rd	<b>Material</b> Steel Pipe	<b>Location C...</b> Main Highw...	<b>Pipeline U...</b> Potable
<b>US Manhole</b> 1031	Total Length	Year Laid 1987	<b>Shape</b> Circular	Location Details	
<b>DS Manhole</b> 1030	Length surveyed 1149.4	Year Renewed	<b>Height</b> 36	<b>Diameter</b> 36	<b>Pipe Joint...</b> 20
<b>Weather</b> Dry	Pipe Segment Reference - FSN				
SPR 6	MPR 13	OPR 19	Purpose		
SPRI N/A	MPRI 1.9	OPRI 0.1	Routine Assessment		
QSR 3200	QMR 2611	Additional Info			
<b>Surveyed By</b> G.Humann	<b>Truck</b> T84	<b>Pre-Cleaning</b> Not Known	<b>Flow Direction</b> Downstream		
<b>Certificate Number</b> 07007898	<b>Media label</b> T84120517	Date Cleaned	<b>Date</b> 20171205	<b>Start Time</b> 15:01	<b>End Time</b> 16:34

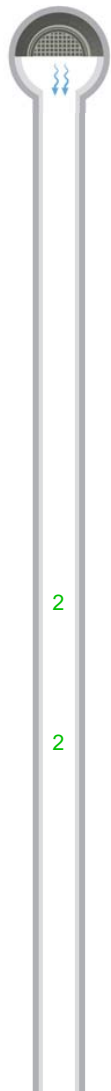

1031

Distance: Pos: Val 1 / 2 : % : Gallons:

	Code: AMH	0.0 ft.	0 - 0		0	
Observation: Access Point Manhole						
Remarks: M/W 1031						
	Code: MWL	0.0 ft.	0 - 0		0	
Observation: Water Level						
Remarks:						
	Code: LFZ	4.0 ft.	12 - 0		0	
Observation: Lining Failure Other						
Remarks: Cracks in liner, Continuous - S01						
	Code: DSZ	33.1 ft.	6 - 0		0	
Observation: Deposits Settled Other						
Remarks: Rock						
	Code: DSF	52.5 ft.	5 - 7		0	
Observation: Deposits Settled Fine						
Remarks:						
	Code: LFZ	82.9 ft.	5 - 0		0	
Observation: Lining Failure Other						
Remarks: Crack in liner						
	Code: MGP	225.6 ft.	0 - 0		0	
Observation: General Photo						
Remarks:						



## **Draft Report Layout**

### **Table of Contents**

#### **List of Tables**

#### **List of Figures**

#### **List of Appendices**

#### **Abbreviations and Acronyms**

### **Executive Summary**

Background

Analysis

Results

Recommendations

### **Chapter 1 – Introduction**

1.1 Purpose

1.2 Goals and Objectives

1.3 Report Organization

1.4 Regulatory Environment

1.5 Consistency with Current Planning Documents

1.6 Study Area

1.7 Planning Horizon

1.8 Acknowledgements

### **Chapter 2 – Population and Land Use**

2.1 General Description

2.2 Population Analysis

2.3 Review of Planning Jurisdictions

2.4 Land Use Analysis

2.4.1 Current Occupancy

2.4.2 Known Development

2.4.3 Build-Out



### **Chapter 3 – Existing Systems**

- 3.1 Water System
  - 3.1.1 Inventory
  - 3.1.2 Facilities
  - 3.1.3 Pressure Zones
- 3.2 Reclaimed Water System
  - 3.2.1 Inventory
  - 3.2.2 Facilities
  - 3.2.3 Pressure Zones
- 3.3 Wastewater System
  - 3.3.1 Inventory
  - 3.3.2 Facilities
  - 3.3.3 Sewersheds

### **Chapter 4 – Evaluation Criteria**

- 4.1 General Description
  - 4.1.1 Level of Service
  - 4.1.2 Purpose and Application of Design Criteria
  - 4.1.3 Purpose and Application of Planning Criteria
  - 4.1.4 Purpose and Application of Risk Analysis
- 4.2 Water System
  - 4.2.1 Design Criteria
  - 4.2.2 Planning Criteria
  - 4.2.3 Risk Criteria
  - 4.2.4 Standards for Pipe Evaluation
  - 4.2.5 Operational Preferences and Constraints
- 4.3 Reclaimed Water System
  - 4.3.1 Design Criteria
  - 4.3.2 Planning Criteria
  - 4.3.3 Risk Criteria
  - 4.3.4 Operational Preferences and Constraints
- 4.4 Wastewater System
  - 4.4.1 Design Criteria
  - 4.4.2 Planning Criteria
  - 4.4.3 Risk Criteria
  - 4.4.4 Standards for Pipe and Manhole Evaluation
  - 4.4.5 Operational Preferences and Constraints



**Chapter 5 – Flow Analysis**

- 5.1 General Description
- 5.2 Water Demand Analysis
  - 5.2.1 Customer Breakdown
  - 5.2.2 Deliveries
  - 5.2.3 Production
  - 5.2.4 Reconciliation of Supply and Demand
  - 5.2.5 Demand by Pressure Zone
  - 5.2.6 Demand Variation
  - 5.2.7 Diurnal Curves
  - 5.2.8 Unit and Area Demand Factors
  - 5.2.9 Demand Projection
- 5.3 Reclaimed Water Demand Analysis
  - 5.3.1 Uses of Reclaimed Water Use
  - 5.3.2 Deliveries
  - 5.3.3 Production
  - 5.3.4 Reconciliation of Supply and Demand
  - 5.3.5 Demand by Pressure Zone
  - 5.3.6 Demand Variation
  - 5.3.7 Response to Meteorological Conditions
  - 5.3.8 Diurnal Curves
  - 5.3.9 Area Demand Factors
  - 5.3.10 Demand Projection
- 5.4 Wastewater Generation
  - 5.4.1 Customer Breakdown
  - 5.4.2 Outflows by Sewershed
  - 5.4.3 Relationship to Water Demand
  - 5.4.4 Variation in Dry Weather Flow
  - 5.4.5 Inflow and Infiltration
  - 5.4.6 Diurnal Curves
  - 5.4.7 Unit and Area Flow Factors
  - 5.4.8 Generation Projection



## **Chapter 6 – Hydraulic Model Development**

- 6.1 General Description
- 6.2 Water Model
  - 6.2.1 Development
  - 6.2.2 Validation
  - 6.2.3 Calibration
  - 6.2.4 Demand Allocation
  - 6.2.5 Operational Settings
  - 6.2.6 Preprogrammed Scenarios
- 6.3 Reclaimed Water Model
  - 6.3.1 Development
  - 6.3.2 Validation
  - 6.3.3 Calibration
  - 6.3.4 Demand Allocation
  - 6.3.5 Operational Settings
  - 6.3.6 Preprogrammed Scenarios
- 6.4 Wastewater Model
  - 6.4.1 Development
  - 6.4.2 Validation
  - 6.4.3 Calibration
  - 6.4.4 Flow Allocation
  - 6.4.5 Operational Settings
  - 6.4.6 Preprogrammed Scenarios

## **Chapter 7 – Water System Analysis**

- 7.1 General Description
  - 7.1.1 Methods for Application of Design Criteria
  - 7.1.2 Methods for Application of Planning Criteria
- 7.2 Supply Capacity Analysis and Condition Assessment
- 7.3 Storage Capacity Analysis and Condition Assessment
- 7.4 Transmission Capacity Analysis and Condition Assessment
- 7.5 Distribution Capacity Analysis and Condition Assessment
- 7.6 Summary of Deficiencies
- 7.7 Methods to Overcome Deficiencies
  - 7.7.1 Engineering Solutions
  - 7.7.2 Operational Solutions
  - 7.7.3 Administrative Solutions



**Chapter 8 – Reclaimed Water System Analysis**

- 8.1 General Description
  - 8.1.1 Methods for Application of Design Criteria
  - 8.1.2 Methods for Application of Planning Criteria
- 8.2 Supply Capacity Analysis and Condition Assessment
- 8.3 Storage Capacity Analysis and Condition Assessment
- 8.4 Transmission Capacity Analysis and Condition Assessment
- 8.5 Distribution Capacity Analysis and Condition Assessment
- 8.6 Summary of Deficiencies
- 8.7 Methods to Overcome Deficiencies
  - 8.7.1 Engineering Solutions
  - 8.7.2 Operational Solutions
  - 8.7.3 Administrative Solutions

**Chapter 9 – Wastewater System Analysis**

- 9.1 General Description
  - 9.1.1 Methods for Application of Design Criteria
  - 9.1.2 Methods for Application of Planning Criteria
- 9.2 Treatment Capacity Analysis and Condition Assessment
- 9.3 Lift Station Capacity Analysis and Condition Assessment
- 9.4 Collection System Capacity Analysis and Condition Assessment
- 9.5 Summary of Deficiencies
- 9.6 Methods to Overcome Deficiencies
  - 9.6.1 Engineering Solutions
  - 9.6.2 Operational Solutions
  - 9.6.3 Administrative Solutions

**Chapter 10 – Capital Improvement Program**

- 10.1 General Description
- 10.2 Cost Estimation Assumptions
- 10.3 Development of Projects
  - 10.3.1 Economies of Scale
  - 10.3.2 Economies of Scope
  - 10.3.3 Integration Across Systems
- 10.4 Project Prioritization
  - 10.4.1 Application of Risk Analysis
  - 10.4.2 Prioritization Criteria
  - 10.4.3 Project Scoring and Ranking
- 10.5 Projects to Address Existing Deficiencies
- 10.6 Projects to Address Regulatory Requirements
- 10.7 Projects to Address District Goals
- 10.8 Projects to Address Future Deficiencies
- 10.9 Developer-Driven Projects
- 10.10 Implementation Plan





**Chapter 11 – Methods of Finance**

- 11.1 General Description
- 11.2 Review Historical Financial Statements
- 11.3 Review of Projected Sales Revenue
- 11.4 Review of Projected Connection Fees
- 11.5 Reconciliation of Future Expenses and Revenues
- 11.6 Capital Requirements
- 11.7 Cost of Capital
- 11.8 Options to Generate Capital

**References**

**Appendices**



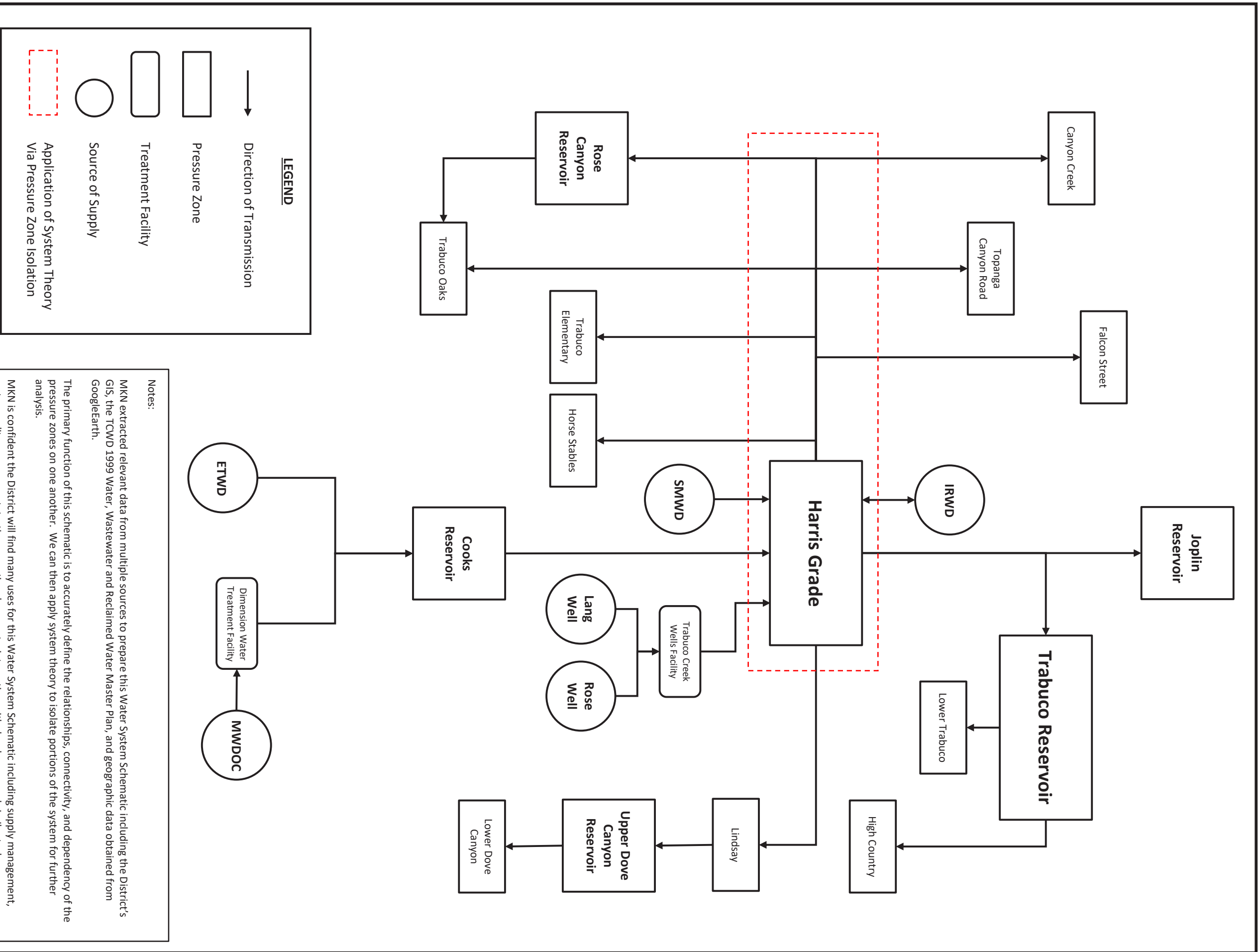

**LEGEND**

- Direction of Transmission
- ▭ Pressure Zone
- ▭ Treatment Facility
- Source of Supply
- ▭ (dashed) Application of System Theory Via Pressure Zone Isolation

**Notes:**

MKN extracted relevant data from multiple sources to prepare this Water System Schematic including the District's GIS, the TCWD 1999 Water, Wastewater and Reclaimed Water Master Plan, and geographic data obtained from GoogleEarth.

The primary function of this schematic is to accurately define the relationships, connectivity, and dependency of the pressure zones on one another. We can then apply system theory to isolate portions of the system for further analysis.

MKN is confident the District will find many uses for this Water System Schematic including supply management, water quality management, testing operational concepts, interaction with developers, and similar tasks.

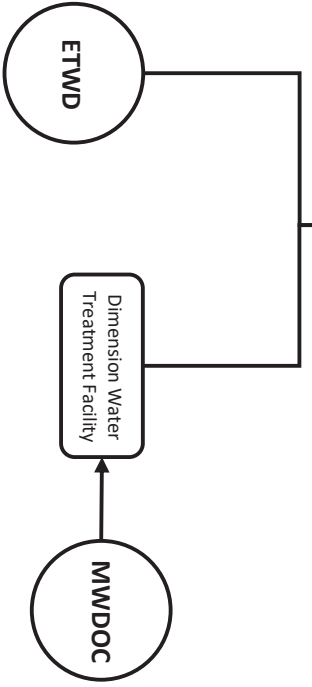
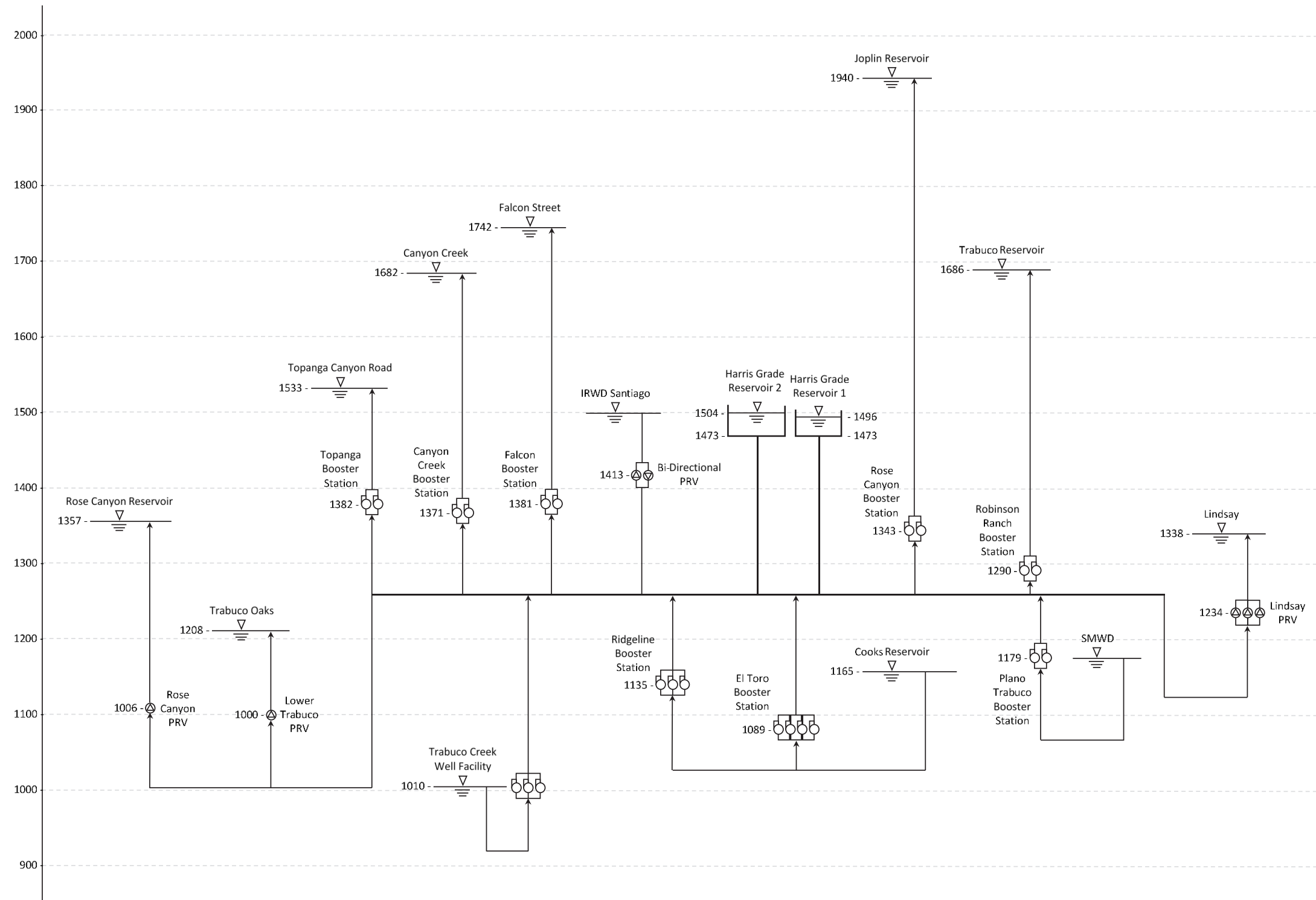

**EXHIBIT 1: WATER SYSTEM SCHEMATIC**



Trabuco Canyon Water District  
 Master Plan and Condition Assessment Study  
 Prepared by: Anthony Herda, PE  
 MKN and Associates  
 16310 Bake Parkway | Irvine, CA 92618





**LEGEND**

- ↑ Direction of Transmission
- ▽ Water Surface
- ▭ Reservoir
- ⊕ Pump
- ⊗ Control Valve

**Notes:**

MKN extracted relevant data from multiple sources to prepare this Hydraulic Profile including the District's GIS, the TCWD 1999 Water, Wastewater and Reclaimed Water Master Plan, and geographic data obtained from GoogleEarth.

As additional details become available, MKN will refine this hydraulic profile to include facility capacities and demographic information related to level of service.

MKN is confident the District will find many uses for this Hydraulic Profile including supply management, preparing maintenance schedules, testing operational concepts, troubleshooting, interaction with developers, and similar tasks.

**EXHIBIT 2: HARRIS GRADE HYDRAULIC PROFILE**

Trabuco Canyon Water District  
Master Plan and Condition Assessment Study

Prepared by: Anthony Herda, PE  
MKN and Associates  
16310 Bake Parkway | Irvine, CA 92618



# TRABUCO CANYON WATER DISTRICT

## Master Plan And Condition Assessment Deliverable Summary

TASK	DELIVERABLE
<b>Task Group 1</b> PM, QC and Workshops	<ul style="list-style-type: none"> <li>• Workshop meeting agenda and minutes (7 total) (Task 1.2)</li> <li>• Microsoft Project Schedule (Task 1.1)</li> <li>• Monthly Invoice (Task 1.1) - including a composite weekly chronicle of work and billings based on actual labor, material, etc., per Task.</li> </ul>
<b>Task Group 2</b> Data Request and Review	<ul style="list-style-type: none"> <li>• Data Request (Task 2.1)</li> <li>• System Schematics (Task 2.5) – Draft</li> <li>• Design Criteria (Task 2.6) – incorporated in TM1</li> <li>• Proposed flow monitoring locations (Task 2.3)</li> </ul>
<b>Task Group 3</b> Supply and Demand	<ul style="list-style-type: none"> <li>• Draft TM1 –Supply and Demand (Task 3.1-3.3)</li> </ul>
<b>Task Group 4</b> Model Development	<ul style="list-style-type: none"> <li>• Draft TM2 – Software Evaluation (Task 4.1)</li> <li>• Hydrant Testing Locations/Form (Task 4.2)</li> <li>• Draft TM3 – Model Development (Task 4.2-4.4)</li> </ul>
<b>Task Group 5</b> Condition Assessment	<ul style="list-style-type: none"> <li>• Condition Assessment Form for LS (Task 5.1)</li> <li>• Completed Condition Assessment Forms – 5 LS (Task 5.1)</li> <li>• DWTP Transmission Main CCTV Plan (Task 5.1)</li> <li>• Preliminary Asset Registry (Task 5.1)</li> <li>• Draft TM 4 – Condition Assessment (Task 5.1)</li> </ul>
<b>Task Group 6</b> CIP Development	<ul style="list-style-type: none"> <li>• CIP Sheet Form (Task 6.1)</li> <li>• Preliminary CIP Projects (Task 6.1)</li> <li>• Draft TM 5 – CIP (Task 6.1)</li> </ul>
<b>Task Group 7</b> Capacity Charge	<ul style="list-style-type: none"> <li>• Asset Valuation Draft (Task 7.1)</li> <li>• Draft Methodology (Task 7.1)</li> <li>• Draft TM 6 – Capacity Charge (Task 7.1)</li> </ul>
<b>Task 8</b> Report Development	<ul style="list-style-type: none"> <li>• Draft Report (Task 8.1)</li> <li>• Final Report (Task 8.1)</li> <li>• Board Presentation (Task 8.2)</li> </ul>

## **TRABUCO CANYON WATER DISTRICT Master Plan And Condition Assessment**

Following selection, and prior to negotiations, MKN shall assemble a detailed scope of work inclusive of the detailed scope of work provided in Section 2 and the following assumptions. Upon review with the District, a final scope of work will be prepared for inclusion in the contract.

### **Task 2.2 Manhole Survey**

- 15 manholes/day for 20 days
- DIR prevailing wage required
- District Operator will assist with traffic control and opening any locked manholes
- Manholes will be selected following review of available data; tentatively set for Workshop #2.

### **Task 2.3 Flow Monitoring**

- 3-man crew for install of (5) flow meters
- Data collection for (7) days, 5-15 minute intervals
- District operations will clean adjoining lines prior to installation of flow monitoring equipment
- Minor traffic control included (35 mph and under streets, no intersection closures)
- This flow monitoring will capture dry weather flow; an optional task for wet weather flow monitoring is provided as Task 2.3A.

### **Task 2.4 CCTV**

- Assume 23,000 feet (approx. 11% system)
- NASSCO PACP CCTV Inspection
- Includes post processing
- Condition report provided as a separate deliverable to District; results integrated into CIP recommendations
- District operations will clean pipelines prior to CCTV.

### **Task 5.1 Transmission CCTV**

- 2-person crew
- 15,840 feet of 16" CMCL
- No hard angles
- Excludes flange removal, opening or shutting down pipe, traffic control, cleaning and draining, and confined space entry
- CCTV equipment will be chlorinated prior to use
- District required to shut down, drain, flush and provide access points every 1,000 feet

### **Task 5.1 LS Condition Assessment**

- Workshop #2 is current target for reviewing condition assessment form. If the District would like to expedite, this discussion can be moved to the Kickoff Meeting which allows the assessment to be completed in December 2021. To facilitate this flexibility, a draft condition assessment form is provided in this proposal as an Appendix item.

### **Task 2.1 Data Review**

- Historical SCADA data for sewage lift station sump level will be made available.
- Historical SCADA data for pump flow and tank level will be made available.
- The water models are complete and functional as provided for the previous master plan.
- The GIS is essentially complete. The District will be responsible for filling gaps in the GIS.
- The District will provide timely access to facilities and infrastructure for site visits, data acquisition, monitoring, hydrant testing.



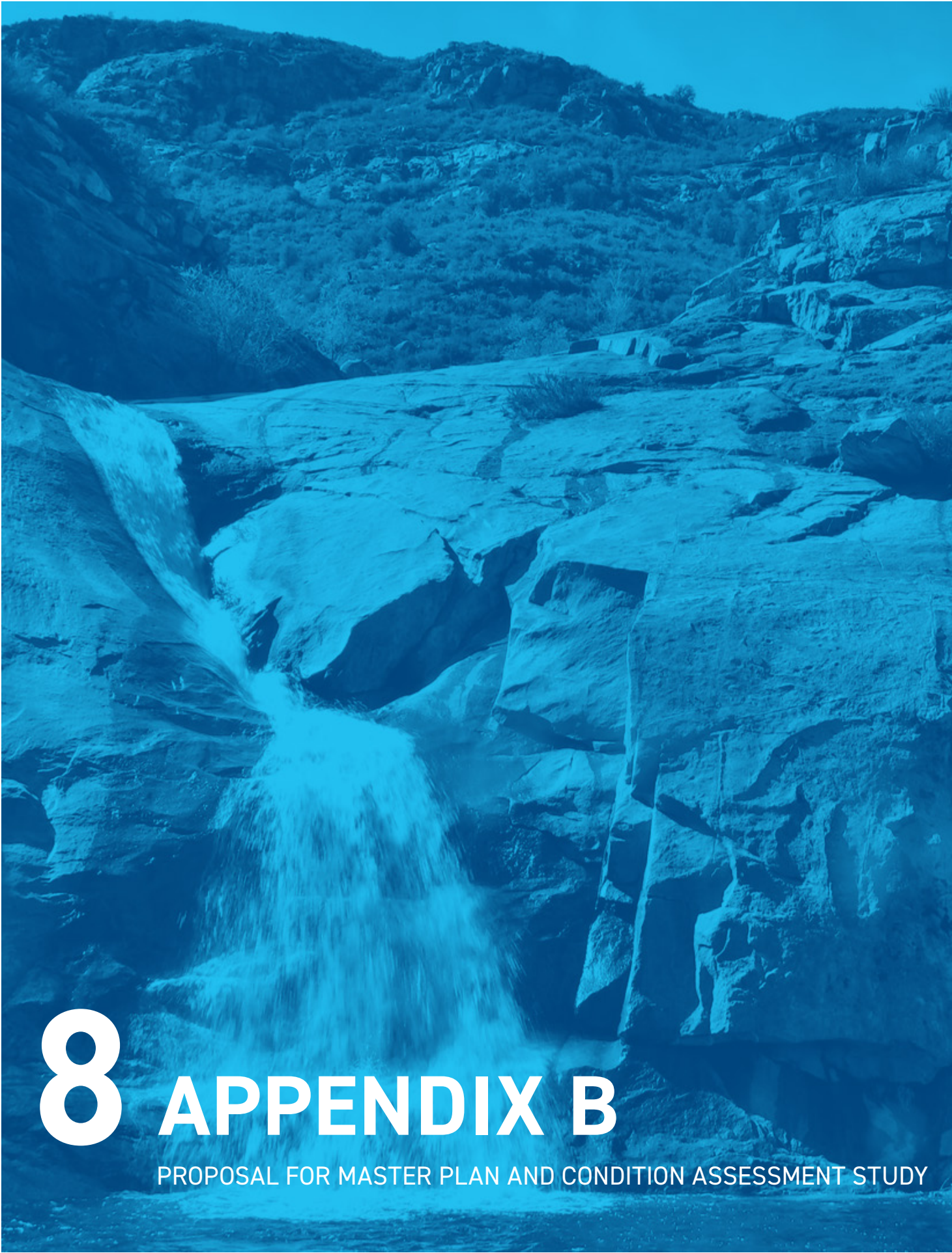

# 8

# APPENDIX B

PROPOSAL FOR MASTER PLAN AND CONDITION ASSESSMENT STUDY



**SECTION 8**

# INSURANCE



## CERTIFICATE OF LIABILITY INSURANCE

DATE (MM/DD/YYYY)  
11/20/2020

THIS CERTIFICATE IS ISSUED AS A MATTER OF INFORMATION ONLY AND CONFERS NO RIGHTS UPON THE CERTIFICATE HOLDER. THIS CERTIFICATE DOES NOT AFFIRMATIVELY OR NEGATIVELY AMEND, EXTEND OR ALTER THE COVERAGE AFFORDED BY THE POLICIES BELOW. THIS CERTIFICATE OF INSURANCE DOES NOT CONSTITUTE A CONTRACT BETWEEN THE ISSUING INSURER(S), AUTHORIZED REPRESENTATIVE OR PRODUCER, AND THE CERTIFICATE HOLDER.

**IMPORTANT:** If the certificate holder is an ADDITIONAL INSURED, the policy(ies) must have ADDITIONAL INSURED provisions or be endorsed. If SUBROGATION IS WAIVED, subject to the terms and conditions of the policy, certain policies may require an endorsement. A statement on this certificate does not confer rights to the certificate holder in lieu of such endorsement(s).

<b>PRODUCER</b> AssuredPartners A/E Insurance Services 19660 10th Ave NE Poulsbo WA 98370	<b>CONTACT NAME:</b> Sarah Fish CA Lic #0M57256	
	<b>PHONE (A/C, No, Ext):</b> 360-626-2961	<b>FAX (A/C, No):</b> 360-626-2961
<b>E-MAIL ADDRESS:</b> sarah.fish@assuredpartners.com		
<b>INSURER(S) AFFORDING COVERAGE</b>		<b>NAIC #</b>
<b>INSURER A:</b> Argonaut Insurance Company		19801
<b>INSURER B:</b> Sentinel Insurance Company		11000
<b>INSURER c:</b> RLI INSURANCE COMPANY		13056
<b>INSURER D:</b>		
<b>INSURER E:</b>		
<b>INSURER F:</b>		

**INSURED** Michael K Nunley and Associates Inc DBA MKN MICHKNU-01  
530 Paulding Circle B  
Arroyo Grande CA 93421

**COVERAGES**      **CERTIFICATE NUMBER:** 250908737      **REVISION NUMBER:**

THIS IS TO CERTIFY THAT THE POLICIES OF INSURANCE LISTED BELOW HAVE BEEN ISSUED TO THE INSURED NAMED ABOVE FOR THE POLICY PERIOD INDICATED. NOTWITHSTANDING ANY REQUIREMENT, TERM OR CONDITION OF ANY CONTRACT OR OTHER DOCUMENT WITH RESPECT TO WHICH THIS CERTIFICATE MAY BE ISSUED OR MAY PERTAIN, THE INSURANCE AFFORDED BY THE POLICIES DESCRIBED HEREIN IS SUBJECT TO ALL THE TERMS, EXCLUSIONS AND CONDITIONS OF SUCH POLICIES. LIMITS SHOWN MAY HAVE BEEN REDUCED BY PAID CLAIMS.

INSR LTR	TYPE OF INSURANCE	ADDL SUBR INSD WVD	POLICY NUMBER	POLICY EFF (MM/DD/YYYY)	POLICY EXP (MM/DD/YYYY)	LIMITS
B	<input checked="" type="checkbox"/> COMMERCIAL GENERAL LIABILITY <input type="checkbox"/> CLAIMS-MADE <input checked="" type="checkbox"/> OCCUR  GEN'L AGGREGATE LIMIT APPLIES PER: <input type="checkbox"/> POLICY <input checked="" type="checkbox"/> PRO-JECT <input type="checkbox"/> LOC OTHER:		52SBAAD9759	12/10/2020	12/10/2021	EACH OCCURRENCE \$ 2,000,000 DAMAGE TO RENTED PREMISES (Ea occurrence) \$ 1,000,000 MED EXP (Any one person) \$ 10,000 PERSONAL & ADV INJURY \$ 2,000,000 GENERAL AGGREGATE \$ 4,000,000 PRODUCTS - COMP/OP AGG \$ 4,000,000 \$
B	<input type="checkbox"/> ANY AUTO <input type="checkbox"/> OWNED AUTOS ONLY <input type="checkbox"/> SCHEDULED AUTOS <input checked="" type="checkbox"/> HIRED AUTOS ONLY <input checked="" type="checkbox"/> NON-OWNED AUTOS ONLY <input type="checkbox"/> AUTOS ONLY		52SBAAD9759	12/10/2020	12/10/2021	COMBINED SINGLE LIMIT (Ea accident) \$ 2,000,000 BODILY INJURY (Per person) \$ BODILY INJURY (Per accident) \$ PROPERTY DAMAGE (Per accident) \$ \$
B	<input checked="" type="checkbox"/> UMBRELLA LIAB <input checked="" type="checkbox"/> OCCUR <input type="checkbox"/> EXCESS LIAB <input type="checkbox"/> CLAIMS-MADE DED <input checked="" type="checkbox"/> RETENTION \$ 10,000		52SBAAD9759	12/10/2020	12/10/2021	EACH OCCURRENCE \$ 1,000,000 AGGREGATE \$ 1,000,000 \$
C	<b>WORKERS COMPENSATION AND EMPLOYERS' LIABILITY</b> ANY PROPRIETOR/PARTNER/EXECUTIVE OFFICER/MEMBER EXCLUDED? (Mandatory in NH) If yes, describe under DESCRIPTION OF OPERATIONS below	Y/N <input type="checkbox"/> N/A	PSW0004772	8/23/2020	8/23/2021	PER STATUTE    OTH-ER E.L. EACH ACCIDENT \$ 1,000,000 E.L. DISEASE - EA EMPLOYEE \$ 1,000,000 E.L. DISEASE - POLICY LIMIT \$ 1,000,000
A	Professional Liability		121AE000402201	6/21/2020	6/21/2021	Per Claim Aggregate 2,000,000 3,000,000

Description of operations/ locations/vehicles (Acord 101, Additional Remarks, Schedules may be attached if more space required)

<b>CERTIFICATE HOLDER</b>  Generic for Proposals	<b>CANCELLATION</b>  SHOULD ANY OF THE ABOVE DESCRIBED POLICIES BE CANCELLED BEFORE THE EXPIRATION DATE THEREOF, NOTICE WILL BE DELIVERED IN ACCORDANCE WITH THE POLICY PROVISIONS.
	AUTHORIZED REPRESENTATIVE 

## SECTION 8

# RESUMES



### **ANTHONY HERDA, PE, MBA** PROJECT MANAGER CIP AND DEVELOPMENT REPORTS

#### EDUCATION

Azusa Pacific University, Azusa, CA

MBA Business Administration

California State University  
Sacramento, California

BS Civil Engineering

#### LICENSES & REGISTRATIONS

California Professional Civil -  
No. C78205

#### PROFESSIONAL ASSOCIATIONS

American Society of Civil Engineers

American Water Works Association

Mr. Herda offers over a decade of experience in water resources engineering planning, specializing in master planning, strategic planning, feasibility studies, hydraulic modeling of water systems, capital planning, urban water management planning, forensics and peer review, public outreach, conceptual design, preliminary design, and related multi-disciplinary studies.

With a diverse background in civil engineer, business management and the humanities, Mr. Herda brings a unique perspective to master planning inclusive of the needs of critical stakeholders. Mr. Herda routinely evaluates and applies all pertinent scientific, engineering, organizational, financial, demographic, economic, regulatory and legal aspects pertaining to successful delivery of master planning services.

**With experience on over 20 utility master plans**, Mr. Herda has extensive training and experience in constructing, calibrating, and utilizing hydraulic models and asset management programs in combination with sound engineering practice to optimize return on invest for water resources expenditures.

Mr. Herda is an accomplished technical writer having prepared dozens of hydraulic analyses for development planning, water master plans, feasibility studies, specific plans, and a variety of other government documents. He is a certified English instructor (TESOL). Mr. Herda is certified business consultant through the Genysys Group with training and experience in strategic planning and stakeholder facilitation.

#### **Water and Sewer Master Plan | Township of Heber, CA**

Project Engineer. Prepared the Heber Public Utility District Water and Sewer Master Plan. Supervised the development and calibration of a water system hydraulic model and a sewer system hydraulic model for HPUD to assist with determination of hydraulic capacity deficiencies under existing and future conditions. Conducted facility inspections of the HPUD Water Treatment Plant and Wastewater Treatment Plant to gather information on performance and capacity deficiencies of existing equipment and to review opportunities to improve treatment processes and effluent quality. Prepared a master plan documenting recommended improvements to address existing conditions and near-term conditions assuming reasonable growth. The master plan was specifically designed and organized to facilitate grant funding applications.

#### **Water Master Plan | Monrovia, CA**

Project Manager. Prepared the City of Monrovia Water Master Plan, requested by new City Manager, Oliver Chi, as part of his ongoing efforts to restructure and modernize city government with a focus on revitalizing essential services and responding to community outreach goals. The water plan was closely coordinated with the sewer plan and the street resurfacing plan through the Public Works Department to take advantage of economies of scope and economies of scale; this was a highly collaborative process involving City management and operations as well as multiple engineering consultants. The water master plan paid special attention to securing groundwater supply independence including recommendations for sufficiency of well capacity, flexibility and redundancy of treatment capacity, and improvements to transmission efficiency between the wellfield and City's primary storage facilities. Additional facility recommendations focused on maximizing existing storage

## **Anthony Herda, PE, MBA**

### RELEVANT EXPERIENCE (CONT.)

and booster pumping infrastructure and efficient utilization of City property for necessary upgrades. As a mature distribution system with pipelines ranging in age from 10 to 120 years old, recommended pipeline projects focused on identifying and replacing obsolete and undersized mains in alignments critical to the integrity of each pressure zone.

#### **Reclaimed Water Master Plan | Corona, CA**

Project Manager. Worked on-site at Corona City Hall with a team of City engineers to prepare the 2018 Reclaimed Water Master Plan. The purpose of the plan was implementation of a City ordinance that requires reclaimed water use for all allowable purposes that are determined to be technically, economically and financially feasible. The plan provided guidance for making the feasibility determinations and identified and prioritized a set of projects in a capital improvement program as well as recommendations for operations and supply management. Responsible for analysis of multiple data sets to build a foundation for planning efforts including demographics, land use, supply, demand, physical and jurisdictional constraints, existing infrastructure, pump efficiency, planned development and O&M costs. The greatest challenge was accommodating a shift in supply. One of the City's three water reclamation facilities was scheduled to be decommissioned and a portion of the City's wastewater diverted to a new regional facility for processing and return as reclaimed water. This shift made an already overstressed transmission pipeline highly inefficient and incapable of meeting customer expectations for flow and pressure. A looped transmission system was proposed which alleviated the bottleneck and opened up a large volume of potential irrigation customer conversions to reclaimed water via the new alignment. The greatest discovery was the City's opportunity to control both supply and demand over the course of the day. About 90% of all reclaimed water was sold to landscape maintenance districts and schools for irrigation. These customers operated within a relatively short window during the night so parks and schools could be occupied during the day. The engineering team demonstrated to operations that they could dramatically improve system performance by spreading their demands across the entire irrigation window rather than programming all irrigation controllers to start at the beginning of the window. The greatest potential for cost savings was implementation of a supply management system. Operators have three choices what to do with finished reclaimed water: sell via the reclaimed water distribution system, replenish the local aquifer, discharge to the Santa Ana River. The engineering team demonstrated to management methods to reduce waste and increase sales.

#### **Sewer Master Plan | Arvin, CA**

Project Manager. Responsible for preparing a comprehensive Sewer Master Plan (SMP) for the wastewater collection system serving the City of Arvin including integration of the following services: hydraulic analysis, condition assessment, regulatory compliance and environmental assessment. Hydraulic analysis includes (1) flow generation analysis for existing and future conditions, (2) computer modeling of the collection system, and (3) identification of pipelines with insufficient capacity. Condition assessment includes (1) review of the lift station, (2) review of CCTV footage for the most critical pipes, (3) inspection of manholes, and (4) identification of infrastructure with deficient performance or high risk of failure. Regulatory compliance involves preparation and submittal of a System Evaluation and Capacity Assurance Plan (SECAP) to the Regional Water Quality Control Board as part of the City's Sewer System Management Plan (SSMP). Environmental assessment involves preparation of a programmatic CEQA document for the SMP, which represents implementation of the City's General Plan with respect to growth and utility services. The Sewer Master Plan culminated in a 20-year Capital Improvement Program (CIP), which is intended to support a sewer rate study.

#### **Water Master Plan | Santa Clarita Valley Water Agency, CA**

Engineering Planner. Assisted in the development and calibration of the Castaic Lake Water Agency hydraulic model and programmed scenarios to evaluate wholesale system performance under extreme loading and production conditions. Services included collection of field data, model development, and capacity analysis. Evaluated seismic vulnerability of wholesale distribution network and recommended alignment of future pipelines to avoid surface rupture zones. Recommended upgrades to operational controls to avoid low pressure at turnouts and flow monitoring for more accurate billing.



## **RYAN GALLAGHER, PE PRINCIPAL-IN-CHARGE**

### **EDUCATION**

California Polytechnic State University, San Luis Obispo  
BS Civil Engineering

### **LICENSES & REGISTRATIONS**

California Professional Engineer - Civil - C74805

### **PROFESSIONAL ASSOCIATIONS**

Tustin City Council (2020-2021)  
Orange County Sanitation District (Board of Directors 2021)  
Orange County Water Association (President 2020 and 2021)  
American Society of Civil Engineers (Santa Barbara/Ventura YMF President 2012)  
American Public Works Association (Ventura County Chapter President 2014)  
Association of Water Agencies Ventura County (President 2013, Board of Directors 2010-2016)

For the past 15 years, has completed over a 100 projects with 25 public agencies in Southern California. **Specific to the District, Ryan brings experience on multiple relevant projects, including the District's Asset Management Procurement, 5 master plans, 15+ hydraulic modeling evaluations, pipeline condition assessments and condition assessment of 25 lift stations.** As an MKN Principal and serving as the Principal-in-Charge for your project, Ryan will ensure that the project meets all expectations of schedule, budget and quality. To that end, he will conduct monthly coordination meetings with our Project Manager, Tony Herda, and ensure that adequate resources are available and that your needs are prioritized.

## **Planning**

### **Asset Management Support, Trabuco Canyon Water District | Trabuco Canyon, CA**

Project Manager for procurement assistance related to a new asset management software, covering the District's water, sewer and recycled water infrastructure and treatment facilities. Services included evaluation of current work order practices, needs assessment, review of current software systems, software evaluation, and recommendations for software selection and optimization.

### **2020 Water and Sewer Master Plan, Channel Islands Beach Community Services District | Channel Islands Harbor, CA**

Project Manager for development of combined water and sewer master plan for service area consisting of approximately 4,000 residents. Effort included updating of current and future supply and demands, capacity assessment, water and sewer hydraulic models, and development of a 5-year capital improvement plan (approximately \$8M).

### **Oxnard Water Business Plan | Oxnard, CA**

Technical Advisor for development of Agency road map for future use of recycled water assets. Includes interviews with City Council and staff, baseline development, and coordination with 11 regional agencies to develop potential use of 7,000 AFY of advanced treated recycled water. Recommendation based on financial impacts and alternatives analysis, provides projects for short term (5-10 years) and long term (10-20 years).

### **Recycled Water Master Plan | Oxnard, CA**

Project Manager for this project that consisted of developing a recycled-water system for the largest city in Ventura County. It also included preparing an implementation plan to serve as the 'road map' for the city, which addressed such institutional issues a: permitting; recycled-water ordinance and administrative code revisions; rates and financing; staffing needs and training; and public outreach strategies. Collaborated with City staff to develop phased expansions of the City's first recycled-water system, identified customers, analyzed storage and ASR opportunities, and created a steady-state and extended-period simulation hydraulic model for system sizing and evaluation.

### **BWRDF Facility Master Plan, Port Hueneme, Port Hueneme Water Agency | Port Hueneme, CA**

Project Manager for facility-wide condition assessment and CIP development for 3 MGD brackish groundwater water facility (BWRDF). The condition assessment included structural, electrical, operations, and process components. Effort included development of a five-year CIP, project descriptions, and cost estimates for \$2.7M in rehabilitation and improvement projects. Developed a model to evaluate water supply impacts and associated costs related to changing groundwater allocations, operating scenarios, water quality targets, and cost of new water. Included



## **Ryan Gallagher, PE**

### **RELEVANT EXPERIENCE (CONT.)**

coordination with various agencies and identification of potential partnerships. Prepared and presented results of the process and results to the PHWA Board of Directors.

#### **Collection System and Lift Stations**

##### **Lift Station Condition Assessment (12 lift stations), South Coast Water District | Laguna Beach, CA**

Project Manager for condition assessment of 12 lift stations for South Coast Water District. Efforts included development of a standard condition assessment form, field evaluation of all lift stations, preparation of observations and condition ratings, and uploading data and form into online ArcGIS platform. Results were used to establish over 160 projects and a 10-year implementation plan based on prioritization ranking and collaboration with District operations staff.

##### **Lift Station Condition Assessment (6 lift stations), Emerald Bay Service District | Laguna Beach, CA**

Project Manager for condition assessment of 6 lift stations for Emerald Bay Service District. Efforts included development of a field evaluation of all lift stations, preparation of observations and condition ratings, and preparation of a 5-year CIP for implementation of project recommendations based on prioritization and collaboration with District operations staff.

##### **Lift Station Condition Assessment (7 lift stations), Channel Islands Beach CSD | Channel Islands Harbor, CA**

As Project Manager, evaluated seven existing raw wastewater lift stations in the District service area. Prepared a report with recommended improvements covering mechanical, structural, electrical, and instrumentation.

##### **Sewer Rehabilitation Planning and Design, Channel Islands Beach Community Services District | Channel Islands Harbor, CA**

Project Manager for development of rehabilitation plan based on review of CCTV and inspection results. Prepared 5-Year CIP based on identification and grouping of priority rehabilitation projects, and conceptual cost estimates. Projects include both cured-in-place liners, spot repair projects, and manhole rehabilitation. Provided design of Phase 1 Improvements which included repair of 25 manholes, replacement of 25 manhole covers, 13 spot repairs 71 top hats and 3,500 feet of full CIPP liner across 10 locations. Project cost was \$442,923 (engineer estimate \$437,000).

##### **Force Main Rehabilitation Constructability Review, Channel Islands Beach Community Services District | Oxnard, CA**

Project Manager for a constructability review of 90 percent design documents related to a sewer rehabilitation project. Improvements included cured-in-place pipeline (CIPP) lining for approximately 2 miles of 8-inch to 12-inch force main. The review included technical evaluation of design drawings and specifications and development of a summary table of comments.

##### **Lift Station B Evaluation, Channel Islands Beach Community Services District | Oxnard, CA**

Project Manager for evaluation of existing wastewater lift station and development of three alternatives for replacement. Project included hydraulic modeling, lift station sizing, constraints analysis and recommendations. The selected project includes a new smaller submerged lift station at an estimated cost of \$900,000. Optimizations identified within the study are estimated to reduce operating and maintenance cost by approximately \$250,000 over a 20-year period.

##### **Force Main Rehabilitation, Channel Islands Beach Community Services District | Channel Islands Harbor, CA**

Project Manager providing construction management services related to cured-in-place lining for approximately 10,300 linear feet of 8-inch and 12-inch wastewater force main piping.

##### **Constructability Review for North Valley Lift Station | Oceanside, CA**

Under On-Call contract, provided constructability review for North Valley Lift Station Improvements Project. The project included replacement of 20-inch sewer force main, demolishing damaged and abandoned equipment, new concrete embankment and installation of two cast in place concrete piers to support existing pipe bridge.

##### **Constructability Review for Pilgrim Creek Lift Station | Oceanside, CA**

Under On-Call contract, provided constructability review for Pilgrim Creek Lift Station Improvements Project. The project included replacement of existing submersible pumps with dry-pit pumps, replacement of bioxide system and associated civil and mechanical modifications.



## HENRY LIANG, PE QA/QC MANAGER

### EDUCATION

Craig School of Business,  
California State University, Fresno

Masters of Business  
Administration

University of California,  
Berkeley

BS Civil and Environmental  
Engineering

### LICENSES & REGISTRATIONS

California Professional Engineer -  
Civil - No. C68442

### PROFESSIONAL ASSOCIATIONS

American Society of Civil  
Engineers

American Council of Engineering  
Companies

Henry Liang has extensive experience in water, wastewater, and water resources projects. He has nearly 20 years of experience in planning and design of municipal water and wastewater systems, water transmission pipelines, wells, pump stations, and water treatment plants. **Mr. Liang has completed over 20 master planning projects, and has experience in integrated planning efforts, including water, wastewater and recycled water.**

### South Coast Water District, Sewer, & Recycled Water Master Plan Updates | Orange County, CA

Project Manager for the water, recycled water, and sewer infrastructure master plans for the South Coast Water District. The updated master planning effort focused on identifying potential local source development options, changes in the District's physical infrastructure due to redevelopment, changes in water demand, wastewater generation, and recycled water use, analysis of demand patterns provided from the District's SCADA system and water meter records, and identify new sources of supply into the water system, including increasing treated groundwater, recycled water system expansion, Dana Point ocean desalination, and indirect potable reuse. The project included updating the model, analysis of the existing and future utility systems, identify deficiencies, and recommending solutions. In-depth analysis also included analyzing water demands, evaluation of storage requirements, analyzing different desalination plant locations, and optimizing interconnections with adjacent systems.

### 2020 Project Program Management, University of California Merced (UCM) | Merced, CA

Engineering Manager for the Program Management of UCM's 2020 Project (Project), which is a \$1.3B program that will add over 1.2 million gross square feet of new campus facilities, athletic facilities, recreational facilities, and off-site improvements. Responsibilities have included developing utility infrastructure technical requirements for the 2020 Project contract documents, investigation UCM's existing utilities, analyzing the available capacity in the existing utilities, coordinating with PG&E, and performing reviews of the Developer's site utility design submittals.

### Ventura Water Master Plan | Ventura, CA

Project Manager for the water master plan update for Ventura Water. The City of Ventura is in the process of infill and redevelopment and changes to its water supply as it adds additional water supply redundancy to its potable water system. The updated master planning effort focuses on identifying potential local source development options; changes in the City's physical infrastructure due to redevelopment, changes in water demand, analysis of demand patterns provided from Ventura Water's SCADA system and water meter records; and new sources of supply into the water system, including increasing treated groundwater. The project includes updating the model, analysis of the existing and future utility systems, identifying deficiencies, and recommending solutions. In-depth analysis also included analyzing water demands, evaluation of storage requirements, analyzing different desalination plant locations, and optimizing interconnections with adjacent systems.

### Water Master Plan, Valley Children's Healthcare | Madera, CA

Served as the project manager in developing a Water Master Plan (WMP) for the hospital to analyze the ability of the existing potable water distribution system to serve existing and future expansion. MKN's scope included analyzing system

## Henry Liang, PE

### RELEVANT EXPERIENCE (CONT.)

water demands, developing demand factors for hospital expansion, developing the hydraulic model using Bentley WaterGEMS, analyzing the system under numerous scenarios including service from a new supply well, identifying required system improvements to resolve deficiencies, and developing the capital improvement program.

#### Water Master Plan Update | Merced, CA

Project Manager for the water master plan update for the City of Merced. The City of Merced has a current population of about 80,000 and is expected to grow significantly over the next 20 years due to the establishment of the University of California at Merced. Mr. Liang helped in the development of the 2009 Master Plan and update the Master Plan in 2013. The 2009 master plan project included development of a system-wide hydraulic water model, model calibration, system analysis, development of the CIP, and preparation of the Master Plan report. The City updated their General Plan in 2012, and Mr. Liang aided with the finalizing of the 2013 Master Plan update to incorporate the zoning changes in the General Plan update. The update also focused on the latest growth projections for UC Merced and identifies system improvements that will be needed for the City to serve the university. The 2013 update included updating the City's water demands and water supply, updates to the water model to include recent improvements, and the development of capital improvement program for the City's water infrastructure to accommodate growth through 2030.

#### Sewer and Storm Drain Master Plan Updates | Atwater, CA

Project manager for the 2010 Storm Drain Master Plan and project engineer for the 2010 Sewer Master Plan. Comprehensive existing system condition assessments were conducted. Hydraulic models were developed for each system and used to analyze the existing sanitary sewer and storm drainage systems. Existing deficiencies were identified and improvements were recommended. The intermediate future and buildout project infrastructure were identified based on the City's General Plan land use. The project deliverables included master plans for the wastewater collection system and storm drainage system. The master plans described the analysis, recommendations, and included a practical capital improvement program.

#### Gunner Ranch W. Infrastructure Master Plan/Groundwater Plan | Madera, CA

Project included development for the Infrastructure Master Plan and Groundwater Plan (GWP) for the 1,100+ acre Gunner Ranch West development located in Southeast Madera County. The Infrastructure Master Plan included planning, analysis and capital improvement development for the water, sewer, and storm drainage infrastructure planned for the development. The project included detailed cost estimates based on several phasing scenarios. Mr. Liang also performed a detailed evaluation of water demands from Valley Children's Hospital, which is located in the development.

#### Reedley Water System Computerized Hydraulic Model and Analysis | Reedley, CA

Project manager for the development of the City's computerized hydraulic model in MWHSoft's H2OMAP. Specific project tasks included development of the model from AutoCAD basemaps, pipe skeletonization, verified and rectified pipe connectivity, assigned model properties and control settings, and performed extensive calibration procedures. Calibration included conducting field tests to obtain real data from well and fire hydrant testing and verification of model characteristics with field test data. Project tasks also included the analysis of three demand scenarios to determine the adequacy of the City's existing storage capacity.

#### Eastern Fresno County Regional Water Study of the Foothill and Mountain Areas | Fresno, CA

Project engineer for the regional study, which was performed to develop suitable information to support recommendations to the County regarding land-use policies, zoning, and development standards in order to protect groundwater resources to sustain water availability in the foothill and mountain areas throughout Fresno County. Specific duties included evaluation of current planning and water development policies, evaluation of the latest master planning documents, processing of the County's available GIS information for water demand projections, development of current and projected water demand estimates based on technical data and population growth, involvement in numerous public information meetings, development of a water balance for the region, and preparation of a final report summarizing our findings and detailing evaluation techniques, results, and costs.



## ROBERT LEPORE, GISP HYDRAULIC MODELING

### EDUCATION

Wentworth Institute of  
Technology, Boston, MA  
BS Environmental Engineering

### LICENSES & REGISTRATIONS

Certified Geographic Information  
System Professional (GISP)  
CA-NV AWWA Certified Water Audit  
Validator  
State Water Resources Control  
Board Water Treatment Operator  
Grade T2  
State Water Resources Control  
Board Water Distribution Operator  
Grade D2

### PROFESSIONAL ASSOCIATIONS

San Luis Obispo Regional GIS  
Collaborative (SLORGC)  
GIS Certification Institute (GISCI)  
Applicant Review Committee  
San Luis Obispo GIS User Group

Robert Lepore has 20 years of experience in developing comprehensive water, wastewater, and recycled water master plans for public utilities with a focus on GIS integration. **Rob has served as a project manager or Water Resource Planner for more than 95 master planning and hydraulic modeling projects in central and southern California. In addition, Rob has prepared 14 Urban Water Management Plans and completed over 50 GIS implementation projects.** He is also a Geographic Information System Professional (GISP) certified by the GIS Certification Institute. Rob has worked for a public utility, GIS consulting firm, and multiple engineering firms, which has allowed him to focus and refine his execution of critical master planning projects for our municipal infrastructure clients.

### Water Master Plan | City of Ventura, CA

Served as Water Resource Planner. Project consisted of a condition assessment and capacity evaluation of the City of Ventura water distribution system. Specific responsibilities included evaluation of existing water production, storage, and distribution facilities; creation of a GIS-based hydraulic water model, review of water quality requirements and goals; development of potential future requirements and evaluation of equipment alternatives; identification of deficiencies under existing and future conditions; and development of Capital Improvements Program (CIP) and cost opinions for existing and future improvements.

### Water Master Plan | City of Grover Beach, CA

Served as Water Resource Planner. Project consisted of a condition assessment and capacity evaluation of the City of Grover Beach water distribution system. Specific responsibilities included evaluation of existing water production, storage, and distribution facilities; creation of a GIS-based hydraulic water model, preparation of GIS-based system atlas, review of water quality requirements and goals; development of potential future requirements and evaluation of equipment alternatives; identification of deficiencies under existing and future conditions; and development of Capital Improvements Program (CIP) and cost opinions for existing and future improvements.

### Water System Master Plan Update | City of Tehachapi, CA

Served as Water Resource Planner. Project consisted of a condition assessment and capacity evaluation of the City of Tehachapi water distribution system. Specific responsibilities included evaluation of existing water production, storage, and distribution facilities; creation of a GIS-based hydraulic water model, preparation of GIS-based system atlas, and review of water quality requirements and goals; development of potential future requirements and evaluation of equipment alternatives; identification of deficiencies under existing and future conditions; and development of Capital Improvements Program and cost opinions for existing and future improvements.

### Water Master Plan Update | Guadalupe, CA

Served as Water Resource Planner. Specific responsibilities included evaluation of existing water production, storage, and distribution facilities; development of potential future requirements and evaluation of equipment alternatives; identification of deficiencies under existing and future conditions; and development of Capital Improvements Program (CIP) and cost opinions for existing and future improvements.

### Supplemental Report to 2014 Water Master Plan | Guadalupe, CA

Served as Project Engineer. In May 2014, Michael K. Nunley and Associates (MKN) completed the City of Guadalupe's Water Master Plan (WMP). The Master Plan evaluated the City's water supply, storage and pumping facilities, and distribution system, and identified Capital Improvement Projects (CIP) necessary to support City demands through buildout. A number of significant planning changes to the City's

## **Rob Lepore, GISP**

### **RELEVANT EXPERIENCE (CONT.)**

water system have occurred since the completion of the Master Plan. MKN developed a supplemental analysis and report to review these changes and identify the impacts to the scope, priority, and necessity of certain recommended CIPs from the 2014 WMP.

#### **Water Master Plan | Guadalupe, CA**

Served as Water Resource Planner. Project consisted of a condition assessment and capacity evaluation of the City of Guadalupe water distribution system. Specific responsibilities included evaluation of existing water production, storage, and distribution facilities; creation of a GIS-based hydraulic water model, preparation of GIS-based system atlas, review of water quality requirements and goals; development of potential future requirements and evaluation of equipment alternatives; identification of deficiencies under existing and future conditions; and development of Capital Improvements Program (CIP) and cost opinions for existing and future improvements.

#### **2020 Urban Water Management Plan | Nipomo, CA**

Serving as Water Resource Planner. In accordance with the Urban Water Management Planning Act of the California Water Code, agencies are required to prepare an update to their UWMP every five years. The updates include change in legislation and the Water Code since the previous UWMP. This project will incorporate the new code requirements including the following: updating the water shortage contingency plan, drought risk assessment, long-term forecast for each water supply source must include climate change and supporting information, incorporation of projected land use changes in demand forecasting, seismic risk assessment and mitigation plan, energy analysis now required for extraction, conveyance, treatment, and distribution, estimates of water savings resulting from new codes/standards now required, inclusion of 5 previous years of system water losses, and inclusion of Sustainable Groundwater Management Act (SGMA) Plan.

#### **2020 Urban Water Management Plan | Atascadero, CA**

Serving as Water Resource Planner. In accordance with the Urban Water Management Planning Act of the California Water Code, agencies are required to prepare an update to their UWMP every five years. The updates include change in legislation and the Water Code since the previous UWMP. This project will incorporate the new code requirements including the following: updating the water shortage contingency plan, drought risk assessment, long-term forecast for each water supply source must include climate change and supporting information, incorporation of projected land use changes in demand forecasting, seismic risk assessment and mitigation plan, energy analysis now required for extraction, conveyance, treatment, and distribution, estimates of water savings resulting from new codes/standards now required, inclusion of 5 previous years of system water losses, and inclusion of Sustainable Groundwater Management Act (SGMA) Plan.

#### **2020 Urban Water Management Plan | Santa Paula, CA**

Serving as Water Resource Planner. In accordance with the Urban Water Management Planning Act of the California Water Code, agencies are required to prepare an update to their UWMP every five years. The updates include change in legislation and the Water Code since the previous UWMP. This project will incorporate the new code requirements including the following: updating the water shortage contingency plan, drought risk assessment, long-term forecast for each water supply source must include climate change and supporting information, incorporation of projected land use changes in demand forecasting, seismic risk assessment and mitigation plan, energy analysis now required for extraction, conveyance, treatment, and distribution, estimates of water savings resulting from new codes/standards now required, inclusion of 5 previous years of system water losses, and inclusion of Sustainable Groundwater Management Act (SGMA) Plan.

#### **Ojai Water System Transmission Main Optimization Study | Ojai, CA**

Served as Water Resource Planner. The purpose of the Ojai Water System Transmission Main Optimization Study was to aid the Casitas Municipal Water District in selecting a replacement alternative for the existing Ojai 12-Inch Pipeline Replacement Project. In addition, the Optimization Study reviewed water system impacts from transferring the Matilija Conduit to the Ojai Water System to serve as a secondary transmission main along Grand Avenue, reviewed the recommended improvements from the November 2018 Final Condition-Based Assessment & Water Master Plan to determine if any of the proposed recommendations require modification (or elimination) based on the updated hydraulic analysis, and determined potential impacts to capital improvement projects currently in design.



**JASON WONG, EIT**  
HYDRAULIC MODELING

**EDUCATION**

University of the Pacific  
Stockton, CA

BS Civil Engineering

MS Civil and Environmental  
Engineering

**LICENSES & REGISTRATIONS**

EIT Certified #163157

**PROFESSIONAL ASSOCIATIONS**

American Society of Civil Engineers  
- Younger Members Forum

Jason Wong is an Assistant Engineer in MKN’s Irvine, California office. His project experience includes planning and design of water and wastewater distribution facilities. He has experience with water supply analysis, modeling water systems, assisting in the design of water and wastewater infrastructure, and performing risk and resilience assessments. **Jason is proficient in ESRI ArcGIS, EPANET, Innovyze InfoWater and InfoSewer, Bentley WaterCAD, SewerCAD, SewerGEMS, and PCSWMM.**

**2020 Water and Wastewater Master Plan Update | Channel Islands Beach, CA**

Serving as assistant engineer. Project included development of combined water and sewer master plan for service area consisting of approximately 4,000 residents. Effort includes updating of current and future supply and demands, capacity assessment, water and sewer hydraulic modeling, and development of 5-year capital improvement plan (approximately \$8M).

**2021 Water Master Plan Update | Guadalupe, CA**

Serving as assistant engineer. Project includes development of a water master plan for a service area consisting of approximately 7,000 residents. Effort includes updating of current and future system demands, analysis of storage and pumping capacity, development of a WaterCAD model, identification of deficiencies under existing and future conditions, and development of a 5-year Capital Improvements Program (approximately \$7.5M).

**Reservoir 2B and 3B Replacement, South Coast Water District | Laguna Beach, CA**

Served as assistant engineer. Developed a feasibility study evaluating replacement of two existing 100,000 gallon steel tanks (two sites). Specific responsibilities included analyzing fire flow and peak hour conditions using InfoWater for the existing system operations, with various tanks and pump stations offline, and with capital improvements or other recommended improvements, developing GIS figures showing hydraulic modeling results, and summarizing results in a technical memorandum.

**Virginia Smith Trust, Infrastructure Analysis & Feasibility Study | Merced, CA**

Serving as assistant engineer. Project includes analysis of water distribution and wastewater systems for a large development in the City of Merced. Effort includes updating system demands and flows, capacity assessment, flow monitoring analysis, updating and analyzing water model using WaterCAD, updating and analyzing wastewater model using PCSWMM, and development of capital improvements, which include development of a new potable water well, installation of a pressure sustaining valve to create a new water pressure zone, and installation of a parallel trunk line to increase sewer flow capacity.

**Ventura Pending Projects Infrastructure Reviews | Ventura, CA**

Serving as assistant engineer. Author of Infrastructure Review Reports for Ventura’s Pending Projects. Project included analysis of water distribution systems using InfoWater and wastewater systems using InfoSewer for new developments in the City of Ventura. Effort includes updating of system demands, updating and analysis of water and wastewater models, identification of deficiencies under existing and future conditions, and development of Capital Improvements Program and cost opinions for existing and future improvements.



## JOSEPH REICHMUTH, PE PIPELINES

### EDUCATION

California Polytechnic State University, San Luis Obispo  
BS Civil Engineering

### LICENSES & REGISTRATIONS

California Professional Engineer - Civil - No. C63124

### PROFESSIONAL ASSOCIATIONS

American Society of Civil Engineers

NASSCO Certification Inspector Training and Certification Program  
- Manhole Rehabilitation  
- Cured In Place Pipe

Mr. Reichmuth brings 20 years of design and field engineering experience with an emphasis in pipeline design, ranging from condition assessment and rehabilitation to planning and design. Pipeline experience includes various rehabilitation and trenchless construction methods, such as horizontal directional drilling and jack-and-bore, and pipeline sizes up to 42-inches. **Mr. Reichmuth is certified for NASSCO ITCP – Cured In Place Pipe and Manhole Rehabilitation**, and has leveraged this experience to complete multiple pipeline assessments and rehabilitation projects, from planning through design.

### 2019 CDBG Waterline Replacement | Grover Beach, CA

Project Engineer. Project consists of abandoning 50-year-old water mains and installation of approximately 2500 linear feet of new 8 and 6 inch water mains, reconnecting water services and installation of new fire hydrants. MKN developed pipeline alignment alternatives, produced plans and specifications for public bid and an opinion of construction cost.

### 2020 CDBG Waterline Replacement | Grover Beach, CA

Project Engineer. Project consists of abandoning 50-year-old water mains and installation of approximately 4800 linear feet of new 8 and 6 inch water mains, reconnecting water services and installation of new fire hydrants. MKN developed pipeline alignment alternatives, produced plans and specifications for public bid and an opinion of construction cost.

### Tognazzini Well Intertie Pipeline | Guadalupe, CA

Project Engineer. Performed design and production of construction documents for 300 feet of 8 inch PVC transmission pipeline to convey well water to the City’s distribution system. Also provided construction phase service for the City.

### Heights Waterline Upgrade | Pismo Beach, CA

Project Engineer. Responsible for design of main water lines to consolidate pressure zones in the area. Design included the preparation of plans, details, specifications, and opinions of cost for the construction of over 3000-lf of 12-inch PVC and 650-lf of 8-inch PVC distribution main. Project also involved connection to a new booster station, replacing a pressure reducing station, reconnecting laterals, fire hydrants, and new meters.

### Branch Street Waterline Improvements, Nipomo CSD | Nipomo, CA

Project Engineer. Project consists of abandoning an aged 6-inch waterline and installation of approximately 400 linear feet of new 8 inch waterline, reconnecting water services and installation of a new fire hydrant. MKN developed project alternatives, provided recommendations to the District, produced plans and specifications for public bid and an opinion of construction cost.

### Eastside Force Main Project, Templeton Community Services District | Templeton, CA

Project Manager. Designed and prepared construction documents for two sewage lift stations. The new lift stations diverted flow currently being conveyed to the City of Paso Robles to the District’s Meadowbrook WWTP. Design included two lift stations consisting of solids handling submersible pumps, rehabilitation of an existing lift station, and a total combined force main length of over 2.5 miles. The force main included three creek crossings and crossing under Highway 101. In addition to open cut trenching of the force main the design included HDD and jack and bore construction techniques.

### Highland Waterline Replacement | San Luis Obispo, CA

Project Engineer. Performed preliminary design services for replacement of 165 feet the City’s 24-inch water transmission line located within Highland Drive. This section of transmission main travels under a creek culvert system and railroad bridge. Due to the site constraints mentioned this section of pipe was not included in a 1995 project

## Joseph Reichmuth, PE

### RELEVANT EXPERIENCE (CONT.)

that replaced remaining portions of the transmission main. MKN analyzed four potential replacement alignments and has identified the alternative that minimizes construction complexities and provides the City with access for future maintenance activities.

#### Highland Way Sewer Line Project | Grover Beach, CA

Project Manager. Developed construction documents for installation of 1,300 linear feet of new sewer line for the City of Grover Beach. This new extent of the sewer collection system is intended to service costumers within the City limits and to eliminate on-site wastewater disposal systems. Project include coordination with proposed construction plans for future development along the alignment.

#### Sulfur Spring Pipeline Construction Phase Services | El Paso de Robles, CA

Project Engineer/Construction Observer. Project to capture spring water that erupted in the City Hall parking lot as a result of the San Simeon Earthquake. Provide construction management and construction observation for collection system, pipeline, and leach field to transport thermal spring water to the Salinas River.

#### Nipomo Waterline Intertie Project, Nipomo CSD | Nipomo, CA

Project Engineer. Responsible for coordination and management of subconsultants (HDD, Environmental/Permits, Geotechnical, and property acquisition). Responsibilities also included the preparation of plans, details, specifications, and opinions of cost for construction.

#### Hollister Avenue Waterline Replacement | Pismo Beach, CA

Project Engineer. Responsibilities included the preparation of plans, details, specifications, and opinions of cost for the construction of 350-lf of 8-inch PVC distribution main. Project also involved reconnecting laterals, fire hydrants, and new meters.

#### Water Treatment Plant Pipe Gallery Improvements | San Luis Obispo, CA

Project Engineer. Performed design services for replacement of 30-inch steel pipe at the City's Water Treatment Plant. A recent pipe inspection identified a portion of a piping that connects the treatment plant to the City's storage and distribution system in need of immediate repair due to sever corrosion. MKN provided the City with technical memorandum outlining potential new piping configurations and methods of rehabilitating the existing pipe. Based on this memorandum the MKN developed construction documents for installation of a new pipe to both replace the severely corroded section for existing pipe and to provide the City more flexibility in operation for the treatment system.

#### Calleguas-Crestview Interconnection Facility | Camarillo, CA

Project Engineer. Performed design services for an interconnection facility to connect the Crestview Mutual Water Company (Crestview) with Calleguas Mutual Water District (Calleguas). This connection will provide Calleguas with an emergency source of water during outages of imported water from other sources. The interconnection facility consist of a subsurface vault with a flow meter, pressure reducing/sustaining valve, and associated piping. The vault is connected to Crestview's water distribution system and Calleguas' Springville Reservoir via 650 feet of 12-inch CML&C welded steel pipe.

#### Arroyo Grande Creek Sewer Rehabilitation Project | Arroyo Grande, CA

Project Engineer. Developed construction documents for the rehabilitation of 2,400 feet of aging sewer main for the City of Arroyo Grande. Due to the close proximity of the sewer main to the Arroyo Grande Creek, cured-in-place-pipe (CIPP) was proposed. Construction phase services was also performed for the City.

#### Terrace Hill and Washwater Tank Rehabilitations | San Luis Obispo, CA

Project Engineer. The City retained MKN to develop construction documents for recoating and repair of two steel water storage tanks. Additionally, MKN developed seismic improvements of the Terrace Hill Tank, revisions to the inlet/outlet piping, and passive mixing systems to address water age and improve turnover of the tank. The seismic improvements included construction documents for a new ringwall footing and anchorage, as well as installation of flexible connections. Based on the anticipated cost of the necessary repairs, MKN assisted the City in evaluating alternatives for abandoning the Terrace Hill Tank. Ultimately, MKN designed a new 16-inch waterline and PRV connection to allow for removal of the tank while maintaining service to the Terrace Hill Zone.



## KEENAN BULL, PE

### LIFT STATION CONDITION ASSESSMENT

#### EDUCATION

Missouri University of Science and Technology

MS Civil Engineering

BS Civil Engineering

#### LICENSES & REGISTRATIONS

California Professional Engineer - Civil - No. C-91138

#### PROFESSIONAL ASSOCIATIONS

American Water Works

Association (AWWA) CA-NV Section  
New Technology Committee Vice-Chair

Orange County Water Association (OCWA)

Water Reuse Association, Orange County

Keenan Bull has over 20 years of experience in civil engineering as a design engineer and project manager for private and municipal water and wastewater treatment operations, water distribution systems, wastewater collection systems, large-diameter pipelines, water conveyance systems, and water storage facilities. Proficiencies include the design, planning, and construction/retrofit of water pumping stations and lift stations; water and wastewater treatment facility mechanical process and yard piping; aboveground water storage tanks; and buried or exposed transmission, distribution, and wastewater collection system infrastructure and pipelines.

#### Lift Station Condition Assessment (12 lift stations), South Coast Water District | Laguna Beach, CA

Project Engineer for condition assessment of 12 lift stations for South Coast Water District. Efforts included development of a standard condition assessment form, field evaluation of all lift stations, preparation of observations and condition ratings, and uploading data and form into online ArcGIS platform. Results were used to establish over 160 projects and a 10-year implementation plan based on prioritization ranking and collaboration with District operations staff.

#### Lift Station Condition Assessment (6 lift stations), Emerald Bay Service District | Laguna Beach, CA

Project Engineer for condition assessment of 6 lift stations for Emerald Bay Service District. Efforts included development of a field evaluation of all lift stations, preparation of observations and condition ratings, and preparation of a 5-year CIP for implementation of project recommendations based on prioritization and collaboration with District operations staff.

#### Lift Station Condition Assessment (7 lift stations), Channel Islands Beach CSD | Channel Islands Harbor, CA

As Project Project, evaluated seven existing raw wastewater lift stations in the District service area. Prepared a report with recommended improvements covering mechanical, structural, electrical, and instrumentation.

#### Lift Station No. 2 Replacement Project | Atascadero, CA

Quality Assurance/Quality Control (QA/QC) Lead. Lift Station No. 2 is the second oldest and one of the largest lift stations within the City's collection system. Project elements included design of a new submersible lift station and pumps on an adjacent property, abandonment of the existing lift station, installation of piping, and installation of new generator, electrical, SCADA, and motor control center. Project also included construction of a new sidewalk and relocation of an existing swale identified as a wetland area.

#### Pilgrim Creek Lift Station Improvements Constructability & Design Review | Oceanside, CA

Provided support as sub-consultant to City of Oceanside during design of repair and replacement alternatives for the existing lift station. Provided technical support by reviewing the project specifications and design plans for mechanical equipment replacement and repair. Project included valves, pumps, piping, spill prevention and mechanical assemblies in addition to site work concrete and asphalt improvements.

#### North Valley Lift Station Force Main Bridge & Channel Improvements Constructability & Design Review | Oceanside, CA

Senior Engineer. Provided support as sub-consultant to City of Oceanside during design of repair and replacement alternatives for the existing lift station and force main design. Provided technical support by reviewing the project specifications and design plans for mechanical equipment replacement and repair. Project included

## **Keenan Bull, PE**

### RELEVANT EXPERIENCE (CONT.)

valves, force main pipeline, and mechanical assemblies in addition to site work concrete.

#### **Roja Lift Station Constructability & Design Review | Oceanside, CA**

Provided support as sub-consultant to City of Oceanside during design of repair and replacement alternatives for the existing lift station. Provided technical support by reviewing the project specifications and design plans for mechanical equipment replacement and repair. Project included valves, pumps and mechanical assemblies in addition to site work concrete and asphalt improvements.

#### **Cambria Community Services District, Cambria WWTP Improvements | Cambria, CA**

Project Senior Engineer for the design of wastewater treatment plant upgrades including the installation of a new flow equalization pump station, screw press feed pump station, RAS/WAS submersible pump station, scum pump replacements, process air blowers and process water pump station replacement. Scope of work also included design for pump replacements and improvements at water distribution booster stations, including a new booster pumping facility and four (4) well pump replacements in the Cambria Community Services District San Simeon and Santa Rosa well fields.

#### **Big Sandy Rancheria (BSR) Wastewater System Improvements | Auberry, CA**

Project Engineer/Technical Lead for the planning and design of the BSR community's wastewater treatment system. The improvements consist of a community-wide gravity wastewater collection system, a secondary treatment plant capable of treating up to 100,000 gpd, a treated effluent disposal system, and decommissioning and abandonment of the existing onsite septic systems. The project planning and construction is funded by the SWRCB Prop 1 Small Community Wastewater Projects program and the funding is administered by RCAC.

#### **Wastewater Treatment Plant Improvements Preliminary Design, Avila Beach CSD | Avila Beach, CA**

Project Senior Engineer. Project consists of preliminary design for wastewater treatment plant improvements to increase capacity for future flows and loadings. The existing WWTP consists of a primary clarifier, trickling filter, secondary clarifiers, chlorination, and an anaerobic sludge digester. Due to the constrained site and need for additional secondary treatment, the project consists of adding a package membrane bioreactor treatment plant as a separate, side-stream treatment system, and improvements to the influent lift station, including concrete coating and pump/piping replacement.

#### **Design-Build Phase Services for the Temecula Valley Regional Water Reclamation Facility (TVRWRF), Eastern Municipal Water District | Temecula, CA**

Project Manager for the design of the Plant 2 24-inch and 18-inch process air pipeline replacement. Design/build alternative delivery was utilized to expedite implementation as part of the TVRWRF expansion project. The new air line was installed to support the TVRWRF Blower Electrification Project implementation to comply with SCAQMD Rule 1110.2. Scope of work included the development of preliminary design plans and performance specifications for design/build project delivery. Total project cost was \$2.8 Million.

#### **Regional Water Reclamation Plant and Horsethief Canyon Water Reclamation Facility (HTCWRF) Expansion and Upgrades, Elsinore Valley Municipal Water District | Lake Elsinore, CA**

Deputy Project Manager for program management of expansion and upgrades to the District's reclamation plant and the HTCWRF. The project involves third-party construction management of the HTCWRF expansion and upgrades. The scope includes program start-up services, strategy development and administration, as-needed staff augmentation, management of technical activities and deliverables, and compliance with financing and permit conditions.

#### **Effluent Pump Station Replacement | Guadalupe, CA**

Project Engineer. Project to replace three submersible pumps at a City effluent pump station with the addition of a flowmeter vault on the effluent line (ongoing).



**BEN CARAGAN,**  
**CPA, MBA**  
**CAPACITY RATE UPDATE**

**EDUCATION**

University of California, Riverside  
MBA Business Administration  
BS Biology

**LICENSES & REGISTRATIONS**

Certified Public Accountant,  
California Board of Accountancy,  
126515

**PROFESSIONAL ASSOCIATIONS**

California Society of CPAs  
American Institute of CPAs

Ben Caragan is an experienced finance and accounting consultant with more than 20 years of experience specializing in financial advisory and works with public agencies that include cities and water districts. Ben's areas of expertise include utility performance evaluations, cost-of-service studies, budgetary preparation, financial statement analysis, financial reporting, preparation of proforma financial statements, fee studies, and management accounting and auditing. He has prepared financial performance and operational audits using analytical procedure components pursuant to auditing standards. In the past three years, Ben has accumulated more than 150 Continuing Professional Education units related to accounting and audit. Lastly, he has also served as the financial advisor to various public agencies in the funding of capital improvements, which included private placements and bond issues in multiple series. Ben is a member of the American Institute of Certified Public Accountants (AICPA), the California Society of Certified Public Accountants (CalCPA) and the California Society of Municipal Finance Officers (CSMFO).

**Funding of Special Districts and Other Water Purveyors - Water, Reclaimed Water, Wastewater Rate and Capacity Charge Studies**

**Water Rate and Capacity Charge Studies | City of Inglewood**

Currently preparing the 2021 Water Capacity Charge Study. Prepared the water and reclaimed water rate studies. Also assisted in the preparation of the Proposition 218 Notice with proper language compliant with state regulations.

**Water, Reclaimed Water and Capacity Charge Studies | Pico Water District**

Prepared an update of the water and reclaimed water rates. Also prepared the District's water capacity charges and a 2017 review of the District's financial condition.

**Reclaimed Water Rate Study | City of Santa Ana**

Prepare the rate analysis of the City's reclaimed water system. The study entailed preparing a cost-of-service study, which included the review of the reclaimed water enterprise's historical and projected costs. The study involved application of AWWA standards in the allocation of fixed and variable costs in determining meter charges and volumetric rates.

**Capacity Charge and Water Rate Studies | South Montebello Irrigation District**

Prepared the water rates and capacity charges and established the District's capacity charges. Also prepared a comparative analysis of meter charges for the District. The capacity charges have since yielded an average of \$800K to \$1 million per housing project for the District's capital improvement fund to expand service to the new housing projects. Served as the District's financial advisor for the private placement refunding of its Installment Sale Agreement.

**Water Rate Study | City of Montebello**

Prepared the City's water rates that have not been updated for nearly a decade. Proposed rates were implemented for automatic multi-year adjustments. Also prepared an analysis of recycled water use and the establishment of a recycled water rate at the City's 120-acre golf course. Assisted in the preparation of the City's grant application for onsite retrofitting of irrigation improvements at the City's golf course. The grant was awarded by the Metropolitan Water District (MWD).

**Consolidation of Water Purveyors**

**Acquisition of a Retail Water District | Santa Clarita Valley Water Agency (formerly Castaic Lake Water Agency)**

Financial Review. Prepared a complex financial analysis for the merger of Castaic Lake Water Agency (CLWA) and Newhall County Water District (NCWD) to determine

## **Ben Caragan, CPA, MBA**

### RELEVANT EXPERIENCE (CONT.)

the financial feasibility of the merger. The financial performance review entailed a review of financial policies, outstanding debt, budget process, audit process, revenues sources, expense activities and capital improvements of CLWA and NCWD. The audit also included financial statement and risk management analysis.

#### [Review of the Sale of the Water System | City of Commerce -](#)

Evaluated the financial aspects of water operators proposing to acquire the City's water system and water rights. The evaluation included the feasibility of continuing with the current operating agreement with its current operator, the sale of the water system, including water rights, and the reorganization of the City's own water enterprise department.

#### [Review of the Sale of the Water System | City of Montebello](#)

Evaluated the feasibility of water operators proposing to acquire the City's water system and water rights. The evaluation included options to either purchase all of the water system facilities, including land and easements or purchase the water system facilities, including land, easements and water rights.

### **Operations Planning**

#### [Rule 20A Operational and Financial Performance Audit | Pacific Gas & Electric \(PG&E\)](#)

Prepared a performance audit of PG&E's Rule 20A Undergrounding Program to determine the effectiveness of its management. The tasks entailed compilation and organization of data to formulate findings and recommendations. The audit included documentation of policies and procedures, processes, funding transactions and historical trends through the utilization of standard audit procedures, such as process owner interviews, data analysis, compliance of current financial and system practices with established company protocols. Deliverables included findings and recommendations.

#### [Financial Performance Audit | Pico Water District](#)

This project required the review of financial statements and the budget to determine the financial standing of the District. It also involved the analytical review of future revenues and expenses, using water use data and planned capital improvement projects. Findings included billing errors due to legacy software issues.

#### [Operational and Financial Audit | County of Orange Facilities Operations](#)

Performed a comprehensive financial and administrative assessment of the County's Facilities Operations Division and (FACOPS) Resources and Development Management Department (RDMD). Reviewed and evaluated internal recharge rates, internal billing procedures and other financial practices of FACOPS/RDMD. Prepared report and communicate findings to department heads. Identified level of services and recommended action steps to resolve deficiencies in billing operations. Developed sound fiscal management procedures to improve operational procedures and eliminate or reduce redundancies in business processes. Conducted interviews with division managers and financial analysts to obtain additional ineffective operational procedures.

### **Public Financing – Water Purveyors**

#### [Community Facilities District for Public Improvements | Eastern Municipal Water District](#)

Project manager for the formation of three (3) separate EMWD CFDs. This special tax district was formed to fund certain water and sewer improvements for the Marsden, Vista Del Valle/Calder Ranch, and Nuevo Meadows Plan Areas. Prepared the rate and method of apportionment of special tax for each of the three CFDs.

#### [Community Facilities Districts for Public Improvements | Jurupa Community Services District](#)

Formed eight (8) special tax districts and prepared the rate and method of apportionment of special tax for each CFD. These special tax districts were formed to fund water and sewer improvements and park and recreation facilities in the Eastvale Area of Riverside County along the I-15 corridor and comprised of several improvement areas.



**CINDY  
ESPARZA, EIT**  
CIP AND REPORT  
DEVELOPMENT

**EDUCATION**

California Polytechnic State University, San Luis Obispo

BS Environmental Engineering

MS Civil and Environmental Engineering

**LICENSES & REGISTRATIONS**

EIT Certified #167850

Cindy Esparza is a driven professional with experience in water and wastewater design, construction management, and advanced water treatment research. Ms. Esparza is a pragmatic problem solver with excellent communication and teamwork skills.

**Channel Islands Beach Community Services District, Water and Wastewater Master Plan | Oxnard, CA**

Assistant Engineer. Completed a master plan of the on-site water and wastewater system serving approximately 4,000 residents. Efforts included calculating water demands and projections, identifying system deficiencies and developing of 5-year capital improvement plan.

**Emerald Bay Services District GIS Mapping Support | Laguna Beach, CA**

Assistant Engineer. Support developing of District wide GIS mapping, including survey of approximately 200 sanitary sewer manholes.

**Port Hueneme Water Agency Urban Water Management Plan | Port Hueneme, CA**

Assistant Engineer. In accordance with the Urban Water Management Planning Act of the California Water Code, agencies are required to prepare an update to their UWMP every five years. This project includes updating the water shortage contingency plan, drought risk assessment, long-term forecast for each water supply source including climate change and supporting information, seismic risk assessment and mitigation plan, and energy analysis for extraction, conveyance, treatment and distribution system.

**City of Port Hueneme Urban Water Management Plan | Port Hueneme, CA**

Assistant Engineer. In accordance with the Urban Water Management Planning Act of the California Water Code, agencies are required to prepare an update to their UWMP every five years. This project includes updating the water shortage contingency plan, drought risk assessment, long-term forecast for each water supply source including climate change and supporting information, seismic risk assessment and mitigation plan, and energy analysis for extraction, conveyance, treatment and distribution system.

**City of Lynwood Urban Water Management Plan | Lynwood, CA**

Assistant Engineer. In accordance with the Urban Water Management Planning Act of the California Water Code, agencies are required to prepare an update to their UWMP every five years. This project includes updating the water shortage contingency plan, drought risk assessment, long-term forecast for each water supply source including climate change and supporting information, seismic risk assessment and mitigation plan, and energy analysis for extraction, conveyance, treatment and distribution system.

**City of Reedley Urban Water Management Plan | Reedley, CA**

Assistant Engineer. In accordance with the Urban Water Management Planning Act of the California Water Code, agencies are required to prepare an update to their UWMP every five years. This project includes updating the water shortage contingency plan, drought risk assessment, long-term forecast for each water supply source including climate change and supporting information, seismic risk assessment and mitigation plan, and energy analysis for extraction, conveyance, treatment and distribution system.

## **Cindy Esparza, EIT**

### RELEVANT EXPERIENCE (CONT.)

#### **Nipomo Community Services District Urban Water Management Plan | Nipomo, CA**

Assistant Engineer. In accordance with the Urban Water Management Planning Act of the California Water Code, agencies are required to prepare an update to their UWMP every five years. The updates include change in legislation and the Water Code since the previous UWMP. This project will incorporate the new code requirements including updating the water shortage contingency plan, drought risk assessment, long-term forecast for each water supply source including climate change and supporting information, seismic risk assessment and mitigation plan, and energy analysis for extraction, conveyance, treatment and distribution system.

#### **Channel Islands Beach Community Services District, Waterline Assessment | Oxnard, CA**

Assistant Engineer. Evaluated an existing potable pipeline located within private easements as part of the District's Capital Improvement Program. Analyzed risk of failures and prepared a conceptual level assessment for multiple alternatives to address concerns with aging pipeline.

#### **Channel Islands Beach Community Services District, Lift Station B | Oxnard, CA**

Assistant Engineer. Provided conceptual level rehabilitation assessment for a 48-year old lift station facing capacity issues and overall aging. Recommended multiple alternatives, compiled cost estimates, and analyzed benefits of each alternative.

#### **Santa Clarita Valley Water Agency Earl Schmidt Filtration Plan (ESFP) Two 5 MG Tanks Improvements Project | Santa Clarita, CA**

Assistant Engineer. Evaluated two existing 5 MG carbon steel tanks to determine structural repair, modifications, and upgrades necessary to meet current code requirements. Assisted in preparing cost estimates, overall condition assessment and recommendations.

#### **City of Grover Beach Urban Water Management Plan | Port Hueneme, CA**

Assistant Engineer. In accordance with the Urban Water Management Planning Act of the California Water Code, agencies are required to prepare an update to their UWMP every five years. The updates include change in legislation and the Water Code since the previous UWMP. This project will incorporate the new code requirements including updating the water shortage contingency plan, drought risk assessment, long-term forecast for each water supply source including climate change and supporting information, seismic risk assessment and mitigation plan, and energy analysis for extraction, conveyance, treatment and distribution system.

**PROFESSIONAL RESUME - GERRY GREEN, PE****EDUCATION**

1986-1994 San Diego Mesa College

1995-1997 San Diego State University, Electrical Engineering

**PROFESSIONAL EXPERIENCE**

California P.E. License E-15691 issued in 1998

Mr. Green is a California registered electrical engineer with over thirty years of electrical design experience in Southern California. He specializes in the design of industrial power systems including electrical and controls systems for water and wastewater facilities. Recent experience is with pump stations, lift stations, wells, and water/wastewater treatment plants. He has performed electrical and control system design, electrical power system studies, equipment condition assessments, and construction support services for several projects in Southern California. Green's active design involvement in these projects from concept design through construction completion keep him current with design trends and advances in equipment technology.

Examples of recent relevant design project experience are outlined below:

- **SCWD Lift Station Condition Assessment**

Electrical Engineer performing condition assessment of electrical and instrumentation equipment at a 12 Lift Stations. Electrical assessments include equipment condition and applicable code review of main electrical panel, motor control center, power panel, generator/transfer switch, and conduit systems. Instrumentation assessments include equipment condition of flow & level instruments, local control panel, and SCADA PLC control panel.

- **EBSD Lift Station Condition Assessment**

Electrical Engineer performing condition assessment of electrical and instrumentation equipment at a 7 Lift Stations. Electrical assessments include equipment condition and applicable code review of main electrical panel, motor control center, power panel, generator/transfer switch, and conduit systems. Instrumentation assessments include equipment condition of flow & level instruments, local control panel, and SCADA PLC control panel.

- **Point Loma Wastewater Treatment Plant – Equipment Condition Assessment**

Electrical Engineer performing condition assessment of electrical and instrumentation equipment at a 240MGD sewage treatment plant. Electrical assessments include equipment condition of power distribution system substations and motor control centers. Instrumentation assessments include equipment condition of flow meters, analyzers, pressure and level transmitters, and local control panels.

- **North City Water Reclamation Plant – Electrical/Instrumentation Condition Assessment**

Electrical Engineer performing condition assessment of electrical and instrumentation equipment at a 30MGD recycled water plant. Electrical assessments include equipment condition of power distribution system substations, switchboards, and motor control centers. Instrumentation assessments include equipment condition of flow meters, analyzers, pressure and level transmitters, and local control panels.

## JOE WENDT, PE

*Structural Design Engineer*

Joe is a Project Manager at PSE with a demonstrated history of experience working on a variety of projects ranging from small residential alterations for homeowners, to large-scale capital improvement projects for municipalities, as well as numerous commercial and industrial related designs. He has completed numerous reservoir and pump station designs for both new structures and existing structure evaluations. Joe is well versed in seismic design and analysis, having successfully completed a wide variety of anchorage designs. Joe has a solid understanding of project needs from initial data gathering and review, to design and analysis, to permitting and construction support, including submittal reviews and on site observations. Joe puts forward thinking into every project by identifying the design requirements early in the project development and coordinating with the appropriate parties and disciplines to ensure the project runs smoothly.

### *Project Experience*

#### **SCWD, Sewer Lift Station Assessment, Laguna Beach, CA**

PSE was contracted to perform a structural conditions assessment of twelve (12) existing sewer lift stations that were owned and operated by South Coast Water District. The lift stations ranged from approximately 15–55 years in age at the time of the assessment. As part of the project, PSE performed visual observations, provided condition ratings and identified visual deficiencies of structural elements for each lift station. In addition, PSE provided recommendations and cost estimates to address identified structural deficiencies. The information provided by PSE was used as part of an overall assessment (civil, structural, electrical) of the District’s lift stations that could be used to develop an asset management program for future planning.

#### **EMWD, Cawston Lift Station Assessment, Hemet, CA**

In developing an integrated plan to support the Purified Water Replenishment Program being implemented in the San Jacinto Valley, the Eastern Municipal Water District required a condition assessment of the Cawston Lift Station. As part of the project team, PSE was contracted to provide a structural condition assessment to evaluate the existing infrastructure as well as identify any constraints for upgrades. PSE completed an ASCE 41 Tier 1 deficiency screening and report for the lift station, which included the main seismic resisting elements of the building, as well as nonstructural items such as life safety systems, mechanical and electrical equipment, light fixtures, etc. The results of the condition assessment were used to identify, prioritize and evaluate alternatives for rehabilitating or replacing the existing lift station.

#### **City of Garden Grove, Pump and Well Building Evaluations, Garden Grove, CA**

As part of a master plan, PSE evaluated multiple pump station facilities spread over 12 sites, including 5 pump/booster station structures and 13 wells structures. Evaluations were in conformance with an ASCE 41 “Seismic Evaluation and Retrofit of Existing Buildings” Tier 1 deficiency screening, which involves rigorous checklists based on the performance objective, hazard level, and type of construction. The screenings were performed considering all structures as Risk Category IV and were based on the review of as-built drawing as well as on-site assessments at each site. Original construction eras for the structures ranged from 1966 to 1997, and the quality and condition of the individual structures varied significantly. PSE provided a report which identified levels of deficiencies and corresponding risks as well as a detailed analysis meeting the ASCE 41 criteria.



### **EDUCATION**

MS, Civil Engineering, Portland State University

BS, Civil Engineering, Portland State University

### **YEARS EXPERIENCE**

7

### **REGISTRATIONS**

Professional Engineer: CA, OR

### **TRAINING**

Post-Disaster Safety Assessment Program (SAP) Evaluator for Cal Office of Emergency Services (OES)

OSHA 2264 - Permit Required Confined Space Entry

### **MEMBERSHIPS**

Structural Engineers Association of San Diego (SEAOSD)

Structural Engineers Association of California (SEAOC)

**PSE**

EMPLOYEES



#### **IRWD, Lake Forest Pump Station, Irvine, CA**

PSE was contracted as the structural engineer of record for the design of a new recycled water pump station for Irvine Ranch Water District. The new building consists of 17' tall reinforced masonry walls, a 5' tall parapet, and flat metal deck roof supported by steel roof framing below. In addition to designing the building, PSE also designed retaining walls and foundations for large equipment (tanks and generator) needed for the project. In coordination with the architect and civil, geotechnical, mechanical, and electrical engineers, PSE worked with the project team from preliminary to final design to develop a building that met the Owner's expectations and provided much needed improvements to IRWD's distributions system.

#### **Riverside Canyon Crest Booster Station, Riverside, CA**

PSE provided structural engineering design services for the Canyon Crest Booster Station project which included design of a foundation for a prefabricated building as well as a retaining wall surrounding the site. The building's reinforced concrete foundation incorporated a custom designed pedestal design to support the pumps as well as special detailing for the buried piping. The wall was designed to retain varying depths of soil on either side and was of reinforced concrete construction. As part of the design, PSE coordinated with the owner to incorporate an 8' tall wrought iron fence for added security. PSE also assisted City Engineers in developing site improvements to address potential slope stability concerns.

#### **City of Wilsonville, Memorial Park Lift Station, Wilsonville, OR**

PSE provided structural design of a new CMU control building for the City's Memorial Park Lift Station. Project scope also included two precast vaults and a precast wet well. PSE also provided bidding and construction support services. The control building design was a rectangular CMU structure with wood trusses, supported on a concrete mat foundation on auger cast piles.

#### **City of Escondido, WTP Improvements, Escondido, CA**

PSE provided structural engineering services for improvements to several existing components within the Escondido-Vista WTP. Scope included new roof mounted equipment and replacement of existing Hypochlorite tank. PSE performed a site visit to verify existing structural components and gather as-built information on the building and foundation elements. PSE analyzed the proposed tank and was able to demonstrate that the existing pad had sufficient capacity for the increased loading for the new tank.

#### **Olivenhain Municipal Water District, DCMWTP Systems Upgrade, Escondido, CA**

As part of the chemical systems upgrades to the David C. McCollom Water Treatment Plant, PSE designed reinforced concrete support pads for various equipment and chemical storage tanks. PSE also generated an engineer's estimate of probable construction costs for the project that could be incorporated into the District's CIP budget for the fiscal year.

#### **Vista Irrigation District 4 Reservoir Evaluations, Vista, CA**

PSE provided a seismic and structural analysis of four of the District's reservoirs ranging in capacities from 0.6MG to 1.3MG. Three of the reservoirs are reinforced concrete with wood roofs and constructed in the mid 1920's. The fourth reservoir is prestressed concrete and constructed in 1978. Our evaluation consisted of a combination of dry and wet inspections of the reservoirs, a full structural analysis based on current code provisions and subsequent recommendations for structural improvements, repairs and/or replacements. PSE's findings were summarized in a technical report which included respective construction cost estimates.

#### **Olivenhain Municipal Water District, Accessway Tie-Back Wall Condition Assessment, Encinitas, CA**

PSE provided the condition assessment of a tie-back retaining wall. The retaining wall supports the Water Treatment Plant access roadway above. PSE completed a site inspection to assess the structural condition of the wall and provided the District with a report of our findings and maintenance/repair recommendations.

#### **Clean Water Services, Butternut Pump Station Utility Shelter Assessment, Beaverton, OR**

PSE was responsible for the analysis of a new steel framed utility shelter to be installed as part of the construction of a new reservoir and pump station. As part of the design, PSE analyzed the proposed structure and generated permit documents for construction. During construction, field conditions required alterations be made to the structure. At which time PSE performed a structural evaluation to observe and assess the existing condition. After which time, PSE coordinated with the contractor to design a repair/alteration of the structure. Deliverables included generation of Stamped Structural Memorandums and Stamped Structural Calculations.

#### **City of Vader, Vader Wastewater Treatment Plant, Vader, WA**

PSE was responsible for the structural design of a new wastewater treatment plant in Vader, Washington. As part of the project, PSE provided the structural design of a Headworks Channel, Chlorination Contact Chamber, and a Lab Building. The headworks channel (300 sq. ft.) and Chlorination Contact Chamber (1,000 sq. ft.) consists of embedded cast-in-place concrete structures with bottom elevations ranging from 4'-6" to 13'-0" below grade. The lab building (1,700 sq. ft.) is a wood framed building with a concrete strip footing and slab on grade foundation. PSE's services for the project included permit document generation, submittal and RFI review, and performance of structural observations.

**PSE**

EMPLOYEES



**Arroyo Grande/Corporate Office**  
530 Paulding Circle, Ste. B  
Arroyo Grande, CA 93420

**Bakersfield**  
1800 21st St., Ste. C  
Bakersfield, CA 93301

**Fresno**  
8405 North Fresno St., Ste. 120  
Fresno, CA 93720

**Irvine**  
16310 Bake Parkway  
Irvine, CA 92618

**Oceanside**  
702 Civic Center Dr., Ste.104  
Oceanside, CA 92054

**Santa Clarita**  
23942 Lyons Ave., Ste. 215  
Newhall, CA 91321

**Ventura**  
121 North Fir St., Ste. G  
Ventura, CA 93001





**Trabuco Canyon Water District  
Master Plan and Condition Assessment Study (Project No. 2122-012)**

	Principal Engineer (RPG, HL)	Principal Engineer (CM and JH)	Principal Engineer (JR)	Principal Planner (AH)	Senior Project Engineer (BC)	Senior Project Engineer (KB)	Sr. Water Resources Planner (RL)	Assistant Engineer II (JW)	Assistant Engineer II (CE)	Supervising Drafter/GIS (JF)	Total Hours (MKN)	Labor (MKN)	ODCs (MKN)	Peterson Structural (Structural)	Gerry Green, Inc. (Electrical)	Greg Borchard (Surveying)	DownStream (Sewer CCTV, Potable CCTV, Flow Monitoring)	Non-Labor Costs	Total Fee	
Hourly Rates	214	214	214	214	201	201	175	156	156	151										
<b>Task Group 1: Project Management, Quality Control, and Workshops</b>																				
<b>Task 1.1 Project Management (11 months)</b>	22			44				11			77	\$15,840	\$ 475	\$ -	\$ -	\$ -	\$ -	\$ -	\$ 475	\$ 16,315
<b>Task 1.2 Meetings and Workshops</b>	14	4	20	10	4	10	28	0	0	90	\$17,064	\$ 512	\$ -	\$ -	\$ -	\$ -	\$ -	\$ -	\$ 512	\$ 17,576
<i>Workshop #1 (Kickoff Meeting)</i>	2	2	8	2			2	4		20	\$3,944	\$ 118	\$ -	\$ -	\$ -	\$ -	\$ -	\$ -	\$ 118	\$ 4,062
<i>Workshop #2 (Model, Software, Field Data Collection)</i>	2		2	2	2	2	4			12	\$2,232	\$ 67	\$ -	\$ -	\$ -	\$ -	\$ -	\$ -	\$ 67	\$ 2,299
<i>Workshop #3 (Supply and Demand)</i>	2		2				2	4		10	\$1,830	\$ 55	\$ -	\$ -	\$ -	\$ -	\$ -	\$ -	\$ 55	\$ 1,885
<i>Workshop #4 (Modeling Review)</i>	2		2				2	4		10	\$1,830	\$ 55	\$ -	\$ -	\$ -	\$ -	\$ -	\$ -	\$ 55	\$ 1,885
<i>Workshop #5 (Condition Assessment)</i>	2	2	2		2		4			12	\$2,310	\$ 69	\$ -	\$ -	\$ -	\$ -	\$ -	\$ -	\$ 69	\$ 2,379
<i>Workshop #6 (CIP Development)</i>	2		2				4			8	\$1,480	\$ 44	\$ -	\$ -	\$ -	\$ -	\$ -	\$ -	\$ 44	\$ 1,524
<i>Workshop #7 (Draft Report/Capacity Charges)</i>	2		2	8			2	4		18	\$3,438	\$ 103	\$ -	\$ -	\$ -	\$ -	\$ -	\$ -	\$ 103	\$ 3,541
<b>Task 1.3 Quality Control (7 deliverables; 5 hrs/per)</b>	35									35	\$7,490	\$ 225	\$ -	\$ -	\$ -	\$ -	\$ -	\$ -	\$ 225	\$ 7,715
<b>Subtotal</b>	<b>71</b>	<b>4</b>	<b>64</b>	<b>10</b>	<b>4</b>	<b>10</b>	<b>39</b>	<b>0</b>	<b>0</b>	<b>202</b>	<b>\$40,394</b>	<b>\$ 1,212</b>	<b>\$ -</b>	<b>\$ -</b>	<b>\$ -</b>	<b>\$ -</b>	<b>\$ -</b>	<b>\$ 1,212</b>	<b>\$ 41,606</b>	
<b>Task Group 2: Data Request and Review</b>																				
<b>Task 2.1 Data Review (TCWD Task 1)</b>			16		8	16	24			64	\$11,576	\$ 347	\$ -	\$ -	\$ -	\$ -	\$ -	\$ -	\$ 347	\$ 11,923
<b>Task 2.3 Flow Monitoring (TCWD Task 8) - Dry wthr, 5 mtrs/ 7 days</b>			4			8	24			36	\$6,000	\$ 180	\$ -	\$ -	\$ -	\$ -	\$ 9,598	\$ -	\$ 1,883	\$ 15,778
<b>Task 2.5 System Schematics (TCWD Task 12) - 1 int./3 system/2 HGL</b>			8			4	12		12	36	\$6,096	\$ 183	\$ -	\$ -	\$ -	\$ -	\$ -	\$ -	\$ 183	\$ 6,279
<b>Task 2.6 Design Criteria (TCWD Task 13)</b>			6			12	4			22	\$4,008	\$ 120	\$ -	\$ -	\$ -	\$ -	\$ -	\$ -	\$ 120	\$ 4,128
<b>Subtotal</b>	<b>0</b>	<b>0</b>	<b>34</b>	<b>0</b>	<b>8</b>	<b>40</b>	<b>64</b>	<b>0</b>	<b>12</b>	<b>158</b>	<b>\$27,680</b>	<b>\$ 830</b>	<b>\$ -</b>	<b>\$ -</b>	<b>\$ -</b>	<b>\$ -</b>	<b>\$ 9,598</b>	<b>\$ -</b>	<b>\$ 10,428</b>	<b>\$ 38,108</b>
<b>Task Group 3: Supply and Demand</b>																				
<b>Task 3.1 Water Supply (TCWD Task 2)</b>	2		24			8		30		64	\$11,644	\$ 349	\$ -	\$ -	\$ -	\$ -	\$ -	\$ -	\$ 349	\$ 11,993
<b>Task 3.2 Water &amp; Recycled Water Demand Analysis</b>	2		8			30		40		80	\$13,630	\$ 409	\$ -	\$ -	\$ -	\$ -	\$ -	\$ -	\$ 409	\$ 14,039
<b>Task 3.3 Wastewater Generation</b>	2		8			16	32			58	\$9,932	\$ 298	\$ -	\$ -	\$ -	\$ -	\$ -	\$ -	\$ 298	\$ 10,230
<b>Subtotal</b>	<b>6</b>	<b>0</b>	<b>40</b>	<b>0</b>	<b>0</b>	<b>54</b>	<b>32</b>	<b>70</b>	<b>0</b>	<b>202</b>	<b>\$35,206</b>	<b>\$ 1,056</b>	<b>\$ -</b>	<b>\$ -</b>	<b>\$ -</b>	<b>\$ -</b>	<b>\$ -</b>	<b>\$ -</b>	<b>\$ 1,056</b>	<b>\$ 36,262</b>
<b>Task Group 4: Model Development</b>																				
<b>Task 4.1 Software Evaluation (TCWD Task 3)</b>	1		6			4	16			27	\$4,694	\$ 141	\$ -	\$ -	\$ -	\$ -	\$ -	\$ -	\$ 141	\$ 4,835
<b>Task 4.2 Model Calibration (TCWD Task 4) -W/RW</b>	4	0	28	0	0	40	40	40	0	152	\$26,328	\$ 790	\$ -	\$ -	\$ -	\$ -	\$ -	\$ -	\$ 790	\$ 27,118
<i>Hydrant Testing (2 days) - plan, form, and site observation</i>			8			8		16		32	\$5,608	\$ 168	\$ -	\$ -	\$ -	\$ -	\$ -	\$ -	\$ 168	\$ 5,776
<i>Water Model Calibration</i>	2		12			16	40			70	\$12,036	\$ 361	\$ -	\$ -	\$ -	\$ -	\$ -	\$ -	\$ 361	\$ 12,397
<i>RW Model Calibration</i>	2		8			16		24		50	\$8,684	\$ 261	\$ -	\$ -	\$ -	\$ -	\$ -	\$ -	\$ 261	\$ 8,945
<b>Task 4.3 Model Development (TCWD Task 6) - WW</b>	2		24			40	80			146	\$25,044	\$ 751	\$ -	\$ -	\$ -	\$ -	\$ -	\$ -	\$ 751	\$ 25,795
<b>Task 4.4 System Capacity Evaluation (TCWD Task 5) - W/RW/WW</b>	2		16			40	24	8	8	98	\$17,052	\$ 512	\$ -	\$ -	\$ -	\$ -	\$ -	\$ -	\$ 512	\$ 17,564
<b>Subtotal</b>	<b>9</b>	<b>0</b>	<b>74</b>	<b>0</b>	<b>0</b>	<b>124</b>	<b>160</b>	<b>48</b>	<b>8</b>	<b>423</b>	<b>\$73,118</b>	<b>\$ 2,194</b>	<b>\$ -</b>	<b>\$ -</b>	<b>\$ -</b>	<b>\$ -</b>	<b>\$ -</b>	<b>\$ -</b>	<b>\$ 2,194</b>	<b>\$ 75,312</b>
<b>Task Group 5: Condition Assessment</b>																				
<b>Task 5.1 Condition Assessment (TCWD Task 11)</b>	12	88	42	22	0	90	36	0	160	16	466	\$86,862	\$ 2,111	\$ 24,357	\$ 22,506	\$ -	\$ -	\$ 23,174	\$ 72,148	\$ 159,010
<i>Construct Inventory Database</i>			2	12		8	24		32	8	86	\$15,004	\$ 450	\$ -	\$ -	\$ -	\$ -	\$ -	\$ 450	\$ 15,454
<b>Condition Assessment for DWTP</b>	12	88			24		40	4	168	4	168	\$33,068	\$ 500	\$ 13,200	\$ 13,068	\$ -	\$ -	\$ -	\$ 26,768	\$ 59,836
<i>Inspect Lift Stations (5 locations)</i>			24			30		32	4	90	\$16,762	\$ 500	\$ 11,157	\$ 9,438	\$ -	\$ -	\$ -	\$ -	\$ 21,095	\$ 37,857
<i>Inspect Transmission Pipeline</i>			16	4		24		24		68	\$12,848	\$ 385	\$ -	\$ -	\$ -	\$ -	\$ 23,174	\$ -	\$ 23,559	\$ 36,407
<i>Life Cycle Cost Analysis</i>			6	4		12		32		54	\$9,180	\$ 275	\$ -	\$ -	\$ -	\$ -	\$ -	\$ -	\$ 275	\$ 9,455
<b>Subtotal</b>	<b>12</b>	<b>88</b>	<b>42</b>	<b>22</b>	<b>0</b>	<b>90</b>	<b>36</b>	<b>0</b>	<b>160</b>	<b>16</b>	<b>466</b>	<b>\$86,862</b>	<b>\$ 2,111</b>	<b>\$ 24,357</b>	<b>\$ 22,506</b>	<b>\$ -</b>	<b>\$ -</b>	<b>\$ 23,174</b>	<b>\$ 72,148</b>	<b>\$ 159,010</b>
<b>Task Group 6: CIP Development</b>																				
<b>Task 6.1 CIP Development (TCWD Task 10) - W/RW/WW</b>	4	4	24		32	36	40		16	156	\$28,236	\$ 847	\$ -	\$ -	\$ -	\$ -	\$ -	\$ -	\$ 847	\$ 29,083
<b>Subtotal</b>	<b>4</b>	<b>4</b>	<b>24</b>	<b>0</b>	<b>32</b>	<b>36</b>	<b>40</b>	<b>0</b>	<b>16</b>	<b>156</b>	<b>\$28,236</b>	<b>\$ 847</b>	<b>\$ -</b>	<b>\$ -</b>	<b>\$ -</b>	<b>\$ -</b>	<b>\$ -</b>	<b>\$ -</b>	<b>\$ 847</b>	<b>\$ 29,083</b>
<b>Task Group 7: Capacity Change Methodology</b>																				
<b>Task 7.1 Capacity Charge Assessment (TCWD Task 14)</b>	2	0	12	120	8	0	12	0	0	154	\$30,596	\$ 918	\$ -	\$ -	\$ -	\$ -	\$ -	\$ -	\$ 918	\$ 31,514
<i>Data Collection and Review</i>				32			6			38	\$7,368	\$ 221	\$ -	\$ -	\$ -	\$ -	\$ -	\$ -	\$ 221	\$ 7,589
<i>Valuation of System (Utilize Inventory from Task 5.1)</i>			4		8					12	\$2,464	\$ 74	\$ -	\$ -	\$ -	\$ -	\$ -	\$ -	\$ 74	\$ 2,538
<i>Develop New Water Capacity Charge Methodology</i>			6	50						56	\$11,334	\$ 340	\$ -	\$ -	\$ -	\$ -	\$ -	\$ -	\$ 340	\$ 11,674
<i>Prepare Report (Draft/Final)</i>	2		2	38			6			48	\$9,430	\$ 283	\$ -	\$ -	\$ -	\$ -	\$ -	\$ -	\$ 283	\$ 9,713
<b>Subtotal</b>	<b>2</b>	<b>0</b>	<b>12</b>	<b>120</b>	<b>8</b>	<b>0</b>	<b>12</b>	<b>0</b>	<b>0</b>	<b>154</b>	<b>\$30,596</b>	<b>\$ 918</b>	<b>\$ -</b>	<b>\$ -</b>	<b>\$ -</b>	<b>\$ -</b>	<b>\$ -</b>	<b>\$ -</b>	<b>\$ 918</b>	<b>\$ 31,514</b>
<b>Task Group 8: Report Development</b>																				
<b>Task 8.1 Report Preparation (TCWD Task 15) - Draft/Final</b>	4	4	16		16	45	32	24	8	149	\$26,171	\$ 785	\$ -	\$ -	\$ -	\$ -	\$ -	\$ -	\$ 785	\$ 26,956
<b>Task 8.2 Report Presentation (TCWD Task 16)</b>	8		12				8			28	\$5,528	\$ 166	\$ -	\$ -	\$ -	\$ -	\$ -	\$ -	\$ 166	\$ 5,694
<b>Subtotal</b>	<b>12</b>	<b>4</b>	<b>28</b>	<b>0</b>	<b>16</b>	<b>45</b>	<b>40</b>	<b>24</b>	<b>8</b>	<b>177</b>	<b>\$31,699</b>	<b>\$ 951</b>	<b>\$ -</b>	<b>\$ -</b>	<b>\$ -</b>	<b>\$ -</b>	<b>\$ -</b>	<b>\$ -</b>	<b>\$ 951</b>	<b>\$ 32,650</b>
<b>TOTAL BUDGET</b>	<b>116</b>	<b>88</b>	<b>54</b>	<b>298</b>	<b>130</b>	<b>158</b>	<b>345</b>	<b>387</b>	<b>302</b>	<b>60</b>	<b>1938</b>	<b>\$353,791</b>	<b>\$ 10,119</b>	<b>\$ 24,357</b>	<b>\$ 22,506</b>	<b>\$ -</b>	<b>\$ 32,771</b>	<b>\$ 89,754</b>	<b>\$ 443,545</b>	
<b>Task Group 9: Optional Scope</b>																				
<b>Task 2.2 Manhole Survey (TCWD Task 7) - 300 manholes</b>	2		8			8		24		42	\$7,284	\$ 219	\$ -	\$ -	\$ 51,920	\$ -	\$ -	\$ -	\$ 52,139	\$ 59,423
<b>Task 2.3A Wet Weather Flow Monitoring (5 Locations) - add to Task 2.3</b>	2		4			8	20			34	\$5,804	\$ 174	\$ -	\$ -	\$ -	\$ 11,248	\$ -	\$ -	\$ 11,422	\$ 17,226
<b>Task 2.4 CCTV (TCWD Task 9) - assume 23,000 feet</b>	2				8	8	16		8	42	\$7,140	\$ 214	\$ -	\$ -	\$ -	\$ -	\$ 31,119	\$ -	\$ 31,333	\$ 38,473
<b>Task 2.5 Traffic Control 3-man crew/day (cost per day, if required)</b>			2							2	\$428	\$ 13	\$ -	\$ -	\$ -	\$ -	\$ 7,110	\$ -	\$ 7,123	\$ 7,551
<b>Task 5.2 Risk Assessment</b>	2		16		4			22	8	52	\$9,296	\$ 279	\$ -	\$ -	\$ -	\$ -	\$ -	\$ -	\$ 279	\$ 9,575
<b>Task 7.2 Implement Water Capacity Charge</b>	2		6	12				16		36	\$6,620	\$ 199	\$ -	\$ -	\$ -	\$ -	\$ -	\$ -	\$ 199	\$ 6,819
<b>TOTAL OPTIONAL BUDGET</b>	<b>10</b>	<b>0</b>	<b>36</b>	<b>12</b>	<b>12</b>	<b>24</b>	<b>36</b>	<b>62</b>	<b>16</b>	<b>208</b>	<b>\$36,572</b>	<b>\$ 1,097</b>	<b>\$ -</b>	<b>\$ -</b>	<b>\$ 51,920</b>	<b>\$ 49,477</b>	<b>\$ -</b>	<b>\$ 102,494</b>	<b>\$ 139,066</b>	

**Trabuco Canyon Water District  
Master Plan and Condition Assessment Study (Project No. 2122-012)**

	Principal Engineer (RPG, HL)	Principal Engineer (CM and JH)	Principal Engineer (JR)	Principal Planner (AH)	Senior Project Engineer (BC)	Senior Project Engineer (KB)	Sr. Water Resources Planner (RL)	Assistant Engineer II (JW)	Assistant Engineer II (CE)	Supervising Drafter/GIS (JF)	Total Hours (MKN)	Labor (MKN)	ODCs (MKN)	Peterson Structural (Structural)	Gerry Green, Inc. (Electrical)	Greg Borchard (Surveying)	DownStream (Sewer CCTV, Potable CCTV, Flow Monitoring)	Non-Labor Costs	Total Fee
Hourly Rates	214	214	214	214	201	201	175	156	156	151									
<b>Task Group 1: Project Management, Quality Control, and Workshops</b>																			
<b>Task 1.1 Project Management (11 months)</b>	22			44				11			77	\$15,840	\$ 475	\$ -	\$ -	\$ -	\$ -	\$ 475	\$ 16,315
<b>Task 1.2 Meetings and Workshops</b>	14	4	20	10	4	10	28	0	0	90	\$17,064	\$ 512	\$ -	\$ -	\$ -	\$ -	\$ -	\$ 512	\$ 17,576
Workshop #1 (Kickoff Meeting)	2	2	8	2			2	4			20	\$3,944	\$ 118	\$ -	\$ -	\$ -	\$ -	\$ 118	\$ 4,062
Workshop #2 (Model, Software, Field Data Collection)	2		2	2	2	2	4			12	\$2,232	\$ 67	\$ -	\$ -	\$ -	\$ -	\$ -	\$ 67	\$ 2,299
Workshop #3 (Supply and Demand)	2		2			2	4			10	\$1,830	\$ 55	\$ -	\$ -	\$ -	\$ -	\$ -	\$ 55	\$ 1,885
Workshop #4 (Modeling Review)	2		2			2	4			10	\$1,830	\$ 55	\$ -	\$ -	\$ -	\$ -	\$ -	\$ 55	\$ 1,885
Workshop #5 (Condition Assessment)	2	2	2		2		4			12	\$2,310	\$ 69	\$ -	\$ -	\$ -	\$ -	\$ -	\$ 69	\$ 2,379
Workshop #6 (CIP Development)	2		2				4			8	\$1,480	\$ 44	\$ -	\$ -	\$ -	\$ -	\$ -	\$ 44	\$ 1,524
Workshop #7 (Draft Report/Capacity Charges)	2		2	8		2	4			18	\$3,438	\$ 103	\$ -	\$ -	\$ -	\$ -	\$ -	\$ 103	\$ 3,541
<b>Task 1.3 Quality Control (7 deliverables; 5 hrs/per)</b>	35									35	\$7,490	\$ 225	\$ -	\$ -	\$ -	\$ -	\$ -	\$ 225	\$ 7,715
<b>Subtotal</b>	<b>71</b>	<b>4</b>	<b>64</b>	<b>10</b>	<b>4</b>	<b>10</b>	<b>39</b>	<b>0</b>	<b>0</b>	<b>202</b>	<b>\$40,394</b>	<b>\$ 1,212</b>	<b>\$ -</b>	<b>\$ -</b>	<b>\$ -</b>	<b>\$ -</b>	<b>\$ -</b>	<b>\$ 1,212</b>	<b>\$ 41,606</b>
<b>Task Group 2: Data Request and Review</b>																			
<b>Task 2.1 Data Review (TCWD Task 1)</b>			16		8	16	24			64	\$11,576	\$ 347	\$ -	\$ -	\$ -	\$ -	\$ -	\$ 347	\$ 11,923
<b>Task 2.3 Flow Monitoring (TCWD Task 8) - Dry wthr, 5 mtrs/ 7 days</b>			4			8	24			36	\$6,000	\$ 180	\$ -	\$ -	\$ -	\$ -	\$ 9,598	\$9,778	\$ 15,778
<b>Task 2.5 System Schematics (TCWD Task 12) - 1 int./3 system/2 HGL</b>			8			4	12		12	36	\$6,096	\$ 183	\$ -	\$ -	\$ -	\$ -	\$ -	\$ 183	\$ 6,279
<b>Task 2.6 Design Criteria (TCWD Task 13)</b>			6			12	4			22	\$4,008	\$ 120	\$ -	\$ -	\$ -	\$ -	\$ -	\$ 120	\$ 4,128
<b>Subtotal</b>	<b>0</b>	<b>0</b>	<b>34</b>	<b>0</b>	<b>8</b>	<b>40</b>	<b>64</b>	<b>0</b>	<b>12</b>	<b>158</b>	<b>\$27,680</b>	<b>\$ 830</b>	<b>\$ -</b>	<b>\$ -</b>	<b>\$ -</b>	<b>\$ -</b>	<b>\$ 9,598</b>	<b>\$ 10,428</b>	<b>\$ 38,108</b>
<b>Task Group 3: Supply and Demand</b>																			
<b>Task 3.1 Water Supply (TCWD Task 2)</b>	2		24			8		30		64	\$11,644	\$ 349	\$ -	\$ -	\$ -	\$ -	\$ -	\$ 349	\$ 11,993
<b>Task 3.2 Water &amp; Recycled Water Demand Analysis</b>	2		8			30		40		80	\$13,630	\$ 409	\$ -	\$ -	\$ -	\$ -	\$ -	\$ 409	\$ 14,039
<b>Task 3.3 Wastewater Generation</b>	2		8			16	32			58	\$9,932	\$ 298	\$ -	\$ -	\$ -	\$ -	\$ -	\$ 298	\$ 10,230
<b>Subtotal</b>	<b>6</b>	<b>0</b>	<b>40</b>	<b>0</b>	<b>0</b>	<b>54</b>	<b>32</b>	<b>70</b>	<b>0</b>	<b>202</b>	<b>\$35,206</b>	<b>\$ 1,056</b>	<b>\$ -</b>	<b>\$ -</b>	<b>\$ -</b>	<b>\$ -</b>	<b>\$ -</b>	<b>\$ 1,056</b>	<b>\$ 36,262</b>
<b>Task Group 4: Model Development</b>																			
<b>Task 4.1 Software Evaluation (TCWD Task 3)</b>	1		6			4	16			27	\$4,694	\$ 141	\$ -	\$ -	\$ -	\$ -	\$ -	\$ 141	\$ 4,835
<b>Task 4.2 Model Calibration (TCWD Task 4) -W/RW</b>	4	0	28	0	0	40	40	40	0	152	\$26,328	\$ 790	\$ -	\$ -	\$ -	\$ -	\$ -	\$ 790	\$ 27,118
Hydrant Testing (2 days) - plan, form, and site observation			8			8		16		32	\$5,608	\$ 168	\$ -	\$ -	\$ -	\$ -	\$ -	\$ 168	\$ 5,776
Water Model Calibration	2		12			16	40			70	\$12,036	\$ 361	\$ -	\$ -	\$ -	\$ -	\$ -	\$ 361	\$ 12,397
RW Model Calibration	2		8			16		24		50	\$8,684	\$ 261	\$ -	\$ -	\$ -	\$ -	\$ -	\$ 261	\$ 8,945
<b>Task 4.3 Model Development (TCWD Task 6) - WW</b>	2		24			40	80			146	\$25,044	\$ 751	\$ -	\$ -	\$ -	\$ -	\$ -	\$ 751	\$ 25,795
<b>Task 4.4 System Capacity Evaluation (TCWD Task 5) - W/RW/WW</b>	2		16			40	24	8	8	98	\$17,052	\$ 512	\$ -	\$ -	\$ -	\$ -	\$ -	\$ 512	\$ 17,564
<b>Subtotal</b>	<b>9</b>	<b>0</b>	<b>74</b>	<b>0</b>	<b>0</b>	<b>124</b>	<b>160</b>	<b>48</b>	<b>8</b>	<b>423</b>	<b>\$73,118</b>	<b>\$ 2,194</b>	<b>\$ -</b>	<b>\$ -</b>	<b>\$ -</b>	<b>\$ -</b>	<b>\$ -</b>	<b>\$ 2,194</b>	<b>\$ 75,312</b>
<b>Task Group 5: Condition Assessment</b>																			
<b>Task 5.1 Condition Assessment (TCWD Task 11)</b>	12	88	42	22	0	90	36	0	160	16	466	\$86,862	\$ 2,111	\$ 24,357	\$ 22,506	\$ -	\$ 23,174	\$72,148	\$ 159,010
Construct Inventory Database			2	12		8	24		32	8	86	\$15,004	\$ 450	\$ -	\$ -	\$ -	\$ -	\$ 450	\$ 15,454
<b>Condition Assessment for DWTP</b>	<b>12</b>	<b>88</b>				<b>24</b>		<b>40</b>	<b>4</b>	<b>168</b>	<b>\$33,068</b>	<b>\$ 500</b>	<b>\$ 13,200</b>	<b>\$ 13,068</b>	<b>\$ -</b>	<b>\$ -</b>	<b>\$ -</b>	<b>\$ 26,768</b>	<b>\$ 59,836</b>
Inspect Lift Stations (5 locations)			24			30		32	4	90	\$16,762	\$ 500	\$ 11,157	\$ 9,438	\$ -	\$ -	\$ -	\$ 21,095	\$ 37,857
Inspect Transmission Pipeline			16	4		24		24		68	\$12,848	\$ 385	\$ -	\$ -	\$ -	\$ -	\$ 23,174	\$23,559	\$ 36,407
Life Cycle Cost Analysis			6	4		12		32		54	\$9,180	\$ 275	\$ -	\$ -	\$ -	\$ -	\$ -	\$ 275	\$ 9,455
<b>Subtotal</b>	<b>12</b>	<b>88</b>	<b>42</b>	<b>22</b>	<b>0</b>	<b>90</b>	<b>36</b>	<b>0</b>	<b>160</b>	<b>16</b>	<b>466</b>	<b>\$86,862</b>	<b>\$ 2,111</b>	<b>\$ 24,357</b>	<b>\$ 22,506</b>	<b>\$ -</b>	<b>\$ 23,174</b>	<b>\$ 72,148</b>	<b>\$ 159,010</b>
<b>Task Group 6: CIP Development</b>																			
<b>Task 6.1 CIP Development (TCWD Task 10) - W/RW/WW</b>	4	4	24		32	36	40		16	156	\$28,236	\$ 847	\$ -	\$ -	\$ -	\$ -	\$ -	\$ 847	\$ 29,083
<b>Subtotal</b>	<b>4</b>	<b>4</b>	<b>24</b>	<b>0</b>	<b>32</b>	<b>36</b>	<b>40</b>	<b>0</b>	<b>16</b>	<b>156</b>	<b>\$28,236</b>	<b>\$ 847</b>	<b>\$ -</b>	<b>\$ -</b>	<b>\$ -</b>	<b>\$ -</b>	<b>\$ -</b>	<b>\$ 847</b>	<b>\$ 29,083</b>
<b>Task Group 7: Capacity Change Methodology</b>																			
<b>Task 7.1 Capacity Charge Assessment (TCWD Task 14)</b>	2	0	12	120	8	0	12	0	0	154	\$30,596	\$ 918	\$ -	\$ -	\$ -	\$ -	\$ -	\$ 918	\$ 31,514
Data Collection and Review				32			6			38	\$7,368	\$ 221	\$ -	\$ -	\$ -	\$ -	\$ -	\$ 221	\$ 7,589
Valuation of System (Utilize Inventory from Task 5.1)			4		8					12	\$2,464	\$ 74	\$ -	\$ -	\$ -	\$ -	\$ -	\$ 74	\$ 2,538
Develop New Water Capacity Charge Methodology			6	50						56	\$11,334	\$ 340	\$ -	\$ -	\$ -	\$ -	\$ -	\$ 340	\$ 11,674
Prepare Report (Draft/Final)	2		2	38			6			48	\$9,430	\$ 283	\$ -	\$ -	\$ -	\$ -	\$ -	\$ 283	\$ 9,713
<b>Subtotal</b>	<b>2</b>	<b>0</b>	<b>12</b>	<b>120</b>	<b>8</b>	<b>0</b>	<b>12</b>	<b>0</b>	<b>0</b>	<b>154</b>	<b>\$30,596</b>	<b>\$ 918</b>	<b>\$ -</b>	<b>\$ -</b>	<b>\$ -</b>	<b>\$ -</b>	<b>\$ -</b>	<b>\$ 918</b>	<b>\$ 31,514</b>
<b>Task Group 8: Report Development</b>																			
<b>Task 8.1 Report Preparation (TCWD Task 15) - Draft/Final</b>	4	4	16		16	45	32	24	8	149	\$26,171	\$ 785	\$ -	\$ -	\$ -	\$ -	\$ -	\$ 785	\$ 26,956
<b>Task 8.2 Report Presentation (TCWD Task 16)</b>	8		12				8			28	\$5,528	\$ 166	\$ -	\$ -	\$ -	\$ -	\$ -	\$ 166	\$ 5,694
<b>Subtotal</b>	<b>12</b>	<b>4</b>	<b>28</b>	<b>0</b>	<b>16</b>	<b>45</b>	<b>40</b>	<b>24</b>	<b>8</b>	<b>177</b>	<b>\$31,699</b>	<b>\$ 951</b>	<b>\$ -</b>	<b>\$ -</b>	<b>\$ -</b>	<b>\$ -</b>	<b>\$ -</b>	<b>\$ 951</b>	<b>\$ 32,650</b>
<b>TOTAL BUDGET</b>	<b>116</b>	<b>88</b>	<b>54</b>	<b>298</b>	<b>130</b>	<b>158</b>	<b>345</b>	<b>387</b>	<b>302</b>	<b>60</b>	<b>1938</b>	<b>\$353,791</b>	<b>\$ 10,119</b>	<b>\$ 24,357</b>	<b>\$ 22,506</b>	<b>\$ -</b>	<b>\$ 32,771</b>	<b>\$ 89,754</b>	<b>\$ 443,545</b>
<b>Task Group 9: Optional Scope</b>																			
<b>Task 2.2 Manhole Survey (TCWD Task 7) - 300 manholes</b>	2		8			8		24		42	\$7,284	\$ 219	\$ -	\$ -	\$ 51,920	\$ -	\$ -	\$52,139	\$ 59,423
<b>Task 2.3A Wet Weather Flow Monitoring (5 Locations) - add to Task 2.3</b>	2		4			8	20			34	\$5,804	\$ 174	\$ -	\$ -	\$ -	\$ 11,248	\$ -	\$11,422	\$ 17,226
<b>Task 2.4 CCTV (TCWD Task 9) - assume 23,000 feet</b>	2				8	8	16		8	42	\$7,140	\$ 214	\$ -	\$ -	\$ -	\$ -	\$ 31,119	\$31,333	\$ 38,473
<b>Task 2.5 Traffic Control 3-man crew/day (cost per day, if required)</b>			2							2	\$428	\$ 13	\$ -	\$ -	\$ -	\$ 7,110	\$ -	\$7,123	\$ 7,551
<b>Task 5.2 Risk Assessment</b>	2		16		4			22	8	52	\$9,296	\$ 279	\$ -	\$ -	\$ -	\$ -	\$ -	\$ 279	\$ 9,575
<b>Task 7.2 Implement Water Capacity Charge</b>	2		6	12				16		36	\$6,620	\$ 199	\$ -	\$ -	\$ -	\$ -	\$ -	\$ 199	\$ 6,819
<b>TOTAL OPTIONAL BUDGET</b>	<b>10</b>	<b>0</b>	<b>36</b>	<b>12</b>	<b>12</b>	<b>24</b>	<b>36</b>	<b>62</b>	<b>16</b>	<b>208</b>	<b>\$36,572</b>	<b>\$ 1,097</b>	<b>\$ -</b>	<b>\$ -</b>	<b>\$ 51,920</b>	<b>\$ 49,477</b>	<b>\$ 102,494</b>	<b>\$ 139,066</b>	