



**REGULAR BOARD MEETING AGENDA  
TRABUCO CANYON WATER DISTRICT  
32003 DOVE CANYON DRIVE, TRABUCO CANYON, CALIFORNIA  
ADMINISTRATIVE FACILITY, BOARD ROOM  
JUNE 16, 2021 AT 7:00 PM**

---

**BOARD OF DIRECTORS**

Don Chadd, President  
Stephen Dopudja, Vice President  
Glenn Acosta, Director  
Edward Mandich, Director  
Michael Safranski, Director

**DISTRICT STAFF**

Fernando Paludi, General Manager  
Michael Perea, District Secretary  
Cindy Byerrum, District Treasurer  
Atkinson, Andelson, Loya, Ruud & Romo  
District General Legal Counsel

---

**AGENDA NOTE:**

*Due to the spread of COVID-19 and as authorized by the Governor's Executive Order, Trabuco Canyon Water District will be holding this Regular Board Meeting by video broadcast and the meeting will be available live by video conference and telephone audio as follows:*

**Video Conferencing:** *You can join the meeting from your computer, tablet, or smartphone by clicking on the following link: <https://zoom.us/j/91386811652>*

**Telephone Audio:** 1 (669) 900-6833 (Toll Free)  
**Access Code:** 913-8681-1652

*Persons desiring to monitor the Board meeting agenda items may download the Board meeting agenda and documents on the internet at [www.tcwd.ca.gov](http://www.tcwd.ca.gov).*

*You may submit public comments by email to the Board at [mperea@tcwd.ca.gov](mailto:mperea@tcwd.ca.gov). In order to be part of the record, emailed comments on meeting agenda items must be received by the District, at the referenced e-mail address, not later than 6:00 p.m. (PDT) on the day of the meeting. Public comments may also be submitted by teleconference during the meeting.*

**CALL MEETING TO ORDER**

**PLEDGE OF ALLEGIANCE**

**RECOGNITION OF SERVICE TO THE DISTRICT – MR. GARY NICOTRA, CUSTOMER SERVICE FIELD TECHNICIAN III**

**ITEMS RECEIVED TOO LATE TO BE AGENDIZED**

*Determine need and take action on item(s) that arose subsequent to posting the Regular Board Meeting agenda.*

**VISITOR PARTICIPATION**

*Members of the public wishing to address the Board regarding a particular item on the agenda are requested to submit public comments by email to the Board at [mperea@tcwd.ca.gov](mailto:mperea@tcwd.ca.gov). Public comments may also be submitted by teleconference during the meeting. The Board President will call on the visitor following the Board's discussion about the matter. Members of the public will be given the opportunity to speak prior to the Board taking action on that item. For persons desiring to make verbal comments and utilizing a translator to present their comments into*

**TRABUCO CANYON WATER DISTRICT  
REGULAR BOARD MEETING AGENDA | JUNE 16, 2021**

*English reasonable time accommodations, consistent with State law, shall be provided. Please limit comments to three minutes.*

**ORAL COMMUNICATION**

*Members of the public who wish to make comment on matters not appearing on the agenda are requested to submit oral communication by email to the Board at [mperea@tcwd.ca.gov](mailto:mperea@tcwd.ca.gov). Public comments may also be submitted by teleconference during the meeting. Under the requirements of State Law, Directors cannot take action on items not identified on the agenda and will not make decisions on such matters. The Board President may direct District Staff to follow up on issues as may be deemed appropriate. For persons desiring to make verbal comments and utilizing a translator to present their comments into English reasonable time accommodations, consistent with State law, shall be provided. Please limit comments to three minutes.*

**DIRECTORS' COMMENTS AND MEETING REPORTS**

**REPORT FROM THE GENERAL MANAGER**

**CONSENT CALENDAR**

*All matters under the Consent Calendar will be approved by one motion unless a Board member or staff member requests a separate action on a specific item.*

**ITEM 1: APPROVAL OF MINUTES OF BOARD MEETING(S)**

**RECOMMENDED ACTION**

*Approve the minutes of the following Board Meetings:*

- 1. May 3, 2021 Special Board Meeting*
- 2. May 19, 2021 Regular Board Meeting*
- 3. May 24, 2021 Special Board Meeting – Budget Workshop*

**ITEM 2: TREASURER'S REPORT**

a. *FINANCE/AUDIT COMMITTEE MEETING*

**RECOMMENDED ACTION:**

*Receive and file the following Finance/Audit Committee Meeting Recap(s):*

- 1. May 12, 2021*

b. *PRESENTATION OF FINANCIALS*

**RECOMMENDED ACTION:**

*Receive and file the preliminary statement(s) of revenues and expenses and preliminary unaudited financials for the following month(s):*

- 1. April 2021*

c. *PAYMENT OF BILLS FOR CONSIDERATION*

**RECOMMENDED ACTION:**

*Ratify the payment of bills for consideration, Payroll and Payroll Taxes for May 2021.*



**TRABUCO CANYON WATER DISTRICT  
REGULAR BOARD MEETING AGENDA | JUNE 16, 2021**

**ITEM 3: ENGINEERING/OPERATIONAL COMMITTEE MEETING**

**RECOMMENDED ACTION:**

*Receive and file the following Engineering/Operational Committee Meeting Recap(s):*

1. *May 5, 2021*

**ITEM 4: EXECUTIVE COMMITTEE MEETING**

**RECOMMENDED ACTION:**

*Receive and file the following Executive Committee Meeting Recap(s):*

1. *March 23, 2021*

**ACTION CALENDAR**

*All matters under the Action Calendar have been reviewed by the General Manager and Staff prior to the Board's consideration.*

**ADMINISTRATIVE MATTERS**

**ITEM 5: RATIFICATION OF DIRECTORS' FEES AND EXPENSES, AND TENTATIVE FUTURE MEETINGS/ ATTENDANCE**

**RECOMMENDED ACTION:**

*Approve the tentative future meetings/attendance items and ratify the Directors' expenses and fees from the following period(s):*

1. *May 2021*

**ITEM 6: PUBLIC HEARING AND ADOPTION OF TRABUCO CANYON WATER DISTRICT'S 2020 URBAN WATER MANAGEMENT PLAN (UWMP) UPDATE, WATER SHORTAGE CONTINGENCY PLAN, AND 2015 UWMP ADDENDUM**

**RECOMMENDED ACTION:**

*Recommend the Board of Directors take the following actions:*

1. *Conduct a Public Hearing to receive public comments related to the approval and adoption of the 2020 Urban Water Management Plan (UWMP) Update, Water Shortage Contingency Plan (WSCP), and 2015 UWMP Addendum*
2. *Adopt Resolution No. 2021- 1290 - Resolution of the Board of Directors of Trabuco Canyon Water District Adopting An Addendum to the Trabuco Canyon Water District 2015 Urban Water Management Plan to Add Appendix K – Reduced Delta Reliance Reporting (Appendix C of 2020 UWMP) –*
3. *Adopt Resolution No. 2021-1291 – Resolution of the Board of Directors of the Trabuco Canyon Water District Adopting the Trabuco Canyon Water District Revised Water Shortage Contingency Plan*
4. *Adopt Resolution No. 2021-1292 – Resolution of the Board of Directors of the Trabuco Canyon Water District Adopting the Trabuco Canyon Water District 2020 Urban Water Management Plan Update*



**TRABUCO CANYON WATER DISTRICT  
REGULAR BOARD MEETING AGENDA | JUNE 16, 2021**

**ITEM 7: DISCUSSION AND POSSIBLE ACTION(S) CONCERNING THE CORONAVIRUS, INCLUDING SAFETY OF DISTRICT SERVICES AND EMPLOYEES, AND IMPACT TO BOARD & COMMITTEE MEETINGS**

**RECOMMENDED ACTION(S):**

*Receive information at the time of the Board meeting and take action(s) as deemed appropriate.*

**ITEM 8: DISCUSSION AND POSSIBLE ACTION(S) RELATED TO THE PROPOSED PALOMA SQUARE DEVELOPMENT (DOVE CANYON PLAZA) AND OTHER RELATED MATTERS**

**RECOMMENDED ACTION:**

*Receive information at the time of the Board meeting and take action(s) as deemed appropriate.*

**ITEM 9: AUTHORIZE ACTIONS FOR TRABUCO CANYON WATER DISTRICT'S FISCAL YEAR 2021/2022 UNDEVELOPED LAND/WATER STANDBY CHARGES (ASSESSMENT) AND SET PUBLIC HEARING**

**RECOMMENDED ACTION(S):**

- 1. Authorize District staff to proceed with actions for setting the Fiscal Year 2021/2022 Undeveloped Land/Water Standby Assessment at \$15.00 per acre or portion thereof; and*
- 2. Agendize Public Hearing and authorize District staff to furnish Notice of Public Hearing on Proposed Fiscal Year 2021/2022 Undeveloped Land/Water Standby Assessments for the July 21, 2021, Regular Board Meeting.*

**FINANCIAL MATTERS**

---

**ITEM 10: DISCUSSION AND ACTION CONCERNING TRABUCO CANYON WATER DISTRICT PROPOSED FISCAL YEAR 2021-22 GENERAL FUND AND CAPITAL IMPROVEMENT PROJECT (CIP) BUDGET**

**RECOMMENDED ACTION:**

- 1. Adopt Resolution No. 2021 - 1293– Resolution of the Board of Directors of Trabuco Canyon Water District of the Trabuco Canyon Water District Approving the General Fund District Budget for Fiscal Year 2021/2022 for an amount of \$12,256,900.*
- 2. Adopt Resolution No. 2021 - 1294 - Resolution of the Board of Directors of Trabuco Canyon Water District of the Trabuco Canyon Water District Approving the Capital Improvement Project, Equipment, and Program Budgets for Fiscal Year 2021/2022 for an amount of \$4,817,500.*

**ITEM 11: DISCUSSION AND ACTION CONCERNING AN INCREASE IN THE SPENDING LIMIT TO AGREEMENT WITH SPECIAL COUNSEL**

**RECOMMENDED ACTION:**

*Authorize an increase in the spending limit to Agreement with Hanson Bridgett LLP for Special Counsel Legal Services in an amount of \$75,000 for a total not-to-exceed amount of \$125,000.*



**TRABUCO CANYON WATER DISTRICT  
REGULAR BOARD MEETING AGENDA | JUNE 16, 2021**

**ITEM 12: APPROVAL OF PROFESSIONAL SERVICES AGREEMENT WITH FIELDMAN ROLAPP & ASSOCIATES FOR FINANCIAL ADVISORY SERVICES**

**RECOMMENDED ACTION:**

*Authorize the General Manager to enter into a professional services agreement with Fieldman Rolapp and Associates for Financial Advisory Services in an amount not-to-exceed \$25,000.*

**ENGINEERING MATTERS**

---

**ITEM 13: DISCUSSION AND POSSIBLE ACTION(S) CONCERNING HERITAGE SEWER LIFT STATION IMPROVEMENTS**

**RECOMMENDED ACTION:**

*Authorize the General Manager to ratify a Contract with JIG Consultants for Engineering Services for Heritage Lift Station Bypass and Piping Improvements in the amount of \$43,440.*

**ITEM 14: DISCUSSION AND POSSIBLE ACTION(S) CONCERNING GOLF CLUB SEWER LIFT STATION IMPROVEMENTS**

**RECOMMENDED ACTION:**

*Authorize the General Manager to ratify a Contract with Hydrotech Electric for Golf Club Lift Station Motor Control Center Replacement in the amount of \$279,340 with a contingency of \$27,934, for a total not-to-exceed amount of \$307,274.*

**ITEM 15: PURCHASE RATIFICATION OF A CUMMINS EMERGENCY PORTABLE 275KW DIESEL GENERATOR**

**RECOMMENDED ACTION:**

*Ratify the purchase of one Cummins Emergency Portable 275KW Diesel Generator for equipment for \$173,981 plus approximately 10% as contingency for a total not-to-exceed amount of \$190,000.*

**ITEM 16: PURCHASE APPROVAL OF A TRAILER MOUNTED EMERGENCY BYPASS PUMP FOR WASTEWATER OPERATIONS**

**RECOMMENDED ACTION:**

*Approve the purchase of one Godwin NC150 Dri-Prime Pump from Xylem Dewatering Solutions for \$83,700 plus approximately 10% as contingency for a total not-to-exceed amount of \$92,070.*

**LEGISLATIVE AND OTHER MATTERS**

---

**ITEM 17: DISCUSSION AND ACTION CONCERNING CALIFORNIA SPECIAL DISTRICT'S ASSOCIATION (CSDA) 2021 BOARD OF DIRECTORS ELECTION – SOUTHERN NETWORK, SEAT A**

**RECOMMENDED ACTION(S):**

- 1. Review and discuss the candidates running for the CSDA Board of Directors, Southern Network, Seat A.*
- 2. Authorize District staff to cast the official election ballot on behalf of District's CSDA Delegate Director Acosta.*



**TRABUCO CANYON WATER DISTRICT  
REGULAR BOARD MEETING AGENDA | JUNE 16, 2021**

**ITEM 18: LOCAL GOVERNMENTAL AND LEGISLATIVE INFORMATIONAL MATTER(S)**

**RECOMMENDED ACTION(S):**

*Review and discuss local government and legislative informational matter(s) and take action(s) as deemed appropriate.*

**CLOSED SESSION(S):**

**CLOSED SESSION NO. 1: PUBLIC EMPLOYEE APPOINTMENT – Pursuant to Government Code Section 54957(b).**

Title: General Legal Counsel

**ITEM 19: REPORT OF ACTION(S) TAKEN IN CLOSED SESSION(S)**

**RECOMMENDED ACTION(S):**

*Provide announcement(s) of action(s) taken in Closed Session(s), if any.*

**ITEMS RECEIVED TOO LATE TO BE AGENDIZED**

---

**ITEM 20:** \_\_\_\_\_

**ITEM 21:** \_\_\_\_\_

**OTHER INFORMATION/MATTERS**

*Reports or comments from the General Manager and/or Staff*

**ADDITIONAL DIRECTORS' COMMENTS**

*Additional reports or comments from Directors*

**END ACTION CALENDAR & ADJOURNMENT**

**AVAILABILITY OF AGENDA MATERIALS**

*Agenda exhibits and other writings that are disclosable public records distributed to all or a majority of the members of the Trabuco Canyon Water District Board of Directors in connection with a matter subject to discussion or consideration at an open meeting of the Board of Directors are available for public inspection at the Trabuco Canyon Water District Administrative Facility, 32003 Dove Canyon Drive, Trabuco Canyon, California (District Administrative Facility) and will be posted online on the District's website located at [www.tcwd.ca.gov](http://www.tcwd.ca.gov). If such writings are distributed to members of the Board less than 72 hours prior to the meeting, they will be available online at [www.tcwd.ca.gov](http://www.tcwd.ca.gov) at the same time as they are distributed to the Board Members, except that, if such writings are distributed immediately prior to or during the meeting, they will be posted online on the District's website located at [www.tcwd.ca.gov](http://www.tcwd.ca.gov).*

**COMPLIANCE WITH THE REQUIREMENTS OF CALIFORNIA GOVERNMENT CODE SECTION 54954.2**

*In compliance with California law and the Americans with Disabilities Act, if you need special disability-related modifications or accommodations, including auxiliary aids or services in order to participate in the meeting, or if you need the agenda provided in an alternative format, please contact the District Secretary at (949) 858-0277, at least 48 hours in advance of the scheduled Board meeting. Notification at least 48 hours prior to the meeting will assist the District in making reasonable arrangements to accommodate your request. The Board Meeting Room is wheelchair accessible.*



**TRABUCO CANYON WATER DISTRICT  
REGULAR BOARD MEETING AGENDA | JUNE 16, 2021**

**FUTURE SCHEDULED REGULAR BOARD MEETINGS OF THE BOARD OF DIRECTORS**

*Upcoming Regular Meetings of the Board are expected to be held at the District Administrative Facility (Board Meeting Room) located at 32003 Dove Canyon Drive, Trabuco Canyon, California 92679 and are currently scheduled as follows:*

**July 21, 2021 | August 18, 2021 | September 15, 2021**

*The District may conduct future meetings via teleconferencing and/or video during the current ongoing emergency situation.*



**TRABUCO CANYON WATER DISTRICT  
REGULAR BOARD MEETING | JUNE 16, 2021**

**CONSENT CALENDAR**

**ITEM 1: APPROVAL OF MINUTES OF BOARD MEETING(S)**

---

**RECOMMENDED ACTION**

*Approve the minutes of the following Board Meetings:*

- 1. May 3, 2021 Special Board Meeting*
- 2. May 19, 2021 Regular Board Meeting*
- 3. May 24, 2021 Special Board Meeting – Budget Workshop*

**CONTACTS (staff responsible): PALUDI/PEREA/SANGI**



## **MINUTES OF THE SPECIAL BOARD MEETING OF THE BOARD OF DIRECTORS OF TRABUCO CANYON WATER DISTRICT | MAY 3, 2021**

The Special Meeting of the Board of Directors of the Trabuco Canyon Water District (TCWD or District) conducted on May 3, 2021 was called to order by President Don Chadd at 6:00 p.m., via conference call in the Board Room at the District Administrative Facility, located at 32003 Dove Canyon Drive, Trabuco Canyon, California. Mr. Michael Perea, District Secretary, transcribed the minutes thereof.

### **DIRECTORS PRESENT VIA CONFERENCE CALL**

President Don Chadd  
Vice President Stephen Dopudja  
Director Glenn Acosta  
Director Edward Mandich  
Director Michael Safranski

### **STAFF PRESENT**

Fernando Paludi, General Manager  
Michael Perea, Assistant General Manager  
Lorrie Lausten, District Engineer

### **DISTRICT CONSULTANTS PRESENT**

Rob Anslow, District General Legal Counsel (Atkinson, Andelson, Loya, Ruud & Romo)

### **PUBLIC PRESENT ON THE CONFERENCE CALL**

None

### **PLEDGE OF ALLEGIANCE**

Director Safranski led the Board of Directors, District staff, and audience in the Pledge of Allegiance.

### **VISITOR PARTICIPATION**

None

### **ORAL COMMUNICATION**

None

### **DIRECTOR'S COMMENTS**

None

### **REPORT FROM THE GENERAL MANAGER**

None

**ACTION CALENDAR**

**ITEM 1: DISCUSSION AND POSSIBLE ACTION(S) CONCERNING TRABUCO CANYON WATER DISTRICT’S WATER SHORTAGE CONTINGENCY PLAN, WATER CONSERVATION ORDINANCE, AND RELATED MATTERS**

Mr. Paludi introduced this matter for Board consideration, and he delivered a PowerPoint presentation which provided an overview of the Department of Water Resources (DWR) Water Shortage Contingency Plan (WSCP) requirements. Mr. Paludi reported that DWR is requiring water purveyors to adopt an updated WSCP in conjunction with the 2020 Urban Water Management Plan (UWMP) for the purpose of planning for reliable water supply to meet current and future demands and are to include six standard water shortage levels which correspond to progressive percentile ranges consistent with Water Code §10632.

Mr. Paludi provided a handout which included the DRAFT Proposed Shortage Response Actions as prepared by District staff for Board consideration. Discussion occurred concerning certain proposed actions and potential impacts of the proposed actions. Director Acosta recommended District staff contract with an independent, third-party public outreach firm to communicate this message to District customers. Mr. Paludi reviewed certain recommended best management practices that are included in the proposed action levels. President Chadd recommended District staff provide an update on this matter to the Community Associations of Rancho (CAR) group at a future meeting. Discussion occurred concerning maintaining a balanced approach to meeting the goals of proposed action levels and providing high quality services to District customers. Mr. Paludi reported that more information concerning this matter would be presented to the Engineering/Operational Committee in June.

**Action:** No action was taken. Direction was provided to the General Manager by the Board of Directors.

**ADJOURNMENT**

President Chadd adjourned the May 3, 2021 Special Board Meeting at 6:55 p.m.



## **MINUTES OF THE REGULAR BOARD MEETING OF THE BOARD OF DIRECTORS OF TRABUCO CANYON WATER DISTRICT | MAY 19, 2021**

The Regular Meeting of the Board of Directors of the Trabuco Canyon Water District (TCWD or District) conducted on May 19, 2021 was called to order by Vice President Dopudja at 7:00 p.m., via conference call in the Board Room at the District Administrative Facility, located at 32003 Dove Canyon Drive, Trabuco Canyon, California. Mr. Rob Anslow, Assistant District Secretary, transcribed the minutes thereof.

### **DIRECTORS PRESENT**

Vice President Stephen Dopudja  
Director Edward Mandich  
Director Michael Safranski

### **DIRECTORS PRESENT ON CONFERENCE CALL**

President Don Chadd

### **DIRECTORS ABSENT**

Director Glenn Acosta

### **STAFF PRESENT**

Fernando Paludi, General Manager  
Lorrie Lausten, District Engineer  
Karen Warner, Principal Accountant  
Lisa Marie Sangi, Executive Assistant

### **STAFF ABSENT**

Michael Perea

### **STAFF PRESENT ON CONFERENCE CALL**

None

### **DISTRICT CONSULTANTS PRESENT**

Rob Anslow, District General Legal Counsel (Atkinson, Andelson, Loya, Ruud & Romo - AALRR)

### **DISTRICT CONSULTANTS PRESENT ON CONFERENCE CALL**

None

### **PUBLIC PRESENT**

Dennis Erdman, Director, Metropolitan Water District of Southern California (MET)

### **PUBLIC PRESENT ON THE CONFERENCE CALL**

Beth Heard, Resident  
Harvey De La Torre, Municipal Water District Orange County

### **PLEDGE OF ALLEGIANCE**

Director Mandich led the Board of Directors, District staff, and audience in the Pledge of Allegiance.

**TRABUCO CANYON WATER DISTRICT  
REGULAR BOARD OF DIRECTORS MEETING MINUTES | MAY 19, 2021**

**ITEMS TOO LATE TO BE AGENDIZED**

None

**VISITOR PARTICIPATION VIA CONFERENCE CALL**

Beth Heard addressed the Board of Directors with regards to the new 180-day Ordinance for developments in the City of Rancho Santa Margarita (RSM) to be taken off the calendar.

A brief discussion occurred concerning challenges associated with residential home fire insurance premium increases and availability.

**ORAL COMMUNICATION**

Mr. Paludi introduced Director Erdman to the Board of Directors. Director Erdman provided a brief update concerning the current drought conditions throughout the State, environmental impacts at the Delta, and regional recycled water projects. Discussion occurred concerning the District's customers positive response and efforts during the 2015 statewide drought.

**DIRECTOR'S COMMENTS**

Director Safranski reported on his attendance at the City of RSM Council Meeting, he mentioned the 180-day closure of projects. The provision is not currently in place.

Director Mandich mentioned the site visit at the Districts Bell Canyon Sewer Lift Station. He was also in attendance at the South Orange County Integrated Regional Watershed Committee Meeting, and he mentioned the presentation on the Oso Creek project and the funds received from Prop 84.

Director Dopudja mentioned the SOCWA meeting he would be attending on Thursday, May 20, 2021. There was a brief discussion on the budget, JPA Agreement and how to work better for the Agencies.

Director Chadd had no comments.

**REPORT FROM THE GENERAL MANAGER**

Mr. Paludi provided the following District personnel updates to the Board:

- Mr. Robbie Barger, Wastewater Operator I had successfully passed his Operator II Certification Examination.
- Mr. Phil Serpas, Lead Water System Operator had successfully passed his Water Distribution 5 Certification Examination.
- Mr. Brent Monson Water Operator III had successfully passed his Water Distribution 4 Certification Examination.
- The District received seven applications for the Wastewater Superintendent recruitment, and an onsite second interview was scheduled for Friday, May 21, 2021.

Mr. Paludi reported the May 2021 On Tap Newsletter included updates on the District's past due balance charges billing policy, Orange County Mosquito and Vector Control District use of drones in the District's service area, and an update on the 2020 Urban Water Management Plan (UWMP). Mr. Paludi commended Mr. Michael Perea for his work preparing the newsletter.

**TRABUCO CANYON WATER DISTRICT  
REGULAR BOARD OF DIRECTORS MEETING MINUTES | MAY 19, 2021**

**CONSENT CALENDAR**

Vice President Dopudja indicated that all matters under the Consent Calendar would be approved by one motion unless a Board member or staff member requests a separate action on a specific item.

**Action:** A motion was made by Director Mandich and seconded by Director Safranski to approve the Consent Calendar.  
The motion was approved by a vote of 4 – 0 – 1 with Director Acosta absent.

**ADMINISTRATIVE MATTERS**

**ITEM 4: RATIFICATION OF DIRECTORS' FEES AND EXPENSES, AND TENTATIVE FUTURE MEETINGS/ ATTENDANCE**

Mr. Paludi presented this matter for Board consideration. There were no requests from the Directors to change or amend the Directors' Fees and Expenses Report.

**Action:** A motion was made by Director Safranski and seconded by Director Mandich to approve of the Consent Calendar.  
The motion was approved by a vote of 4 – 0 – 1 with Director Acosta absent.

**ITEM 5: DISCUSSION AND POSSIBLE ACTION(S) CONCERNING THE CORONAVIRUS, INCLUDING SAFETY OF DISTRICT SERVICES AND EMPLOYEES, AND IMPACT TO BOARD & COMMITTEE MEETINGS**

Mr. Paludi provided a brief update on COVID-19 related matters throughout the County, and he reported that Orange County is currently in the yellow tier. Mr. Paludi added that the Office of the Governor has indicated that the State is scheduled to open on June 15, 2021, and to eliminate the current tiered system with certain caveats. Mr. Paludi reported that District staff are currently targeting a reopening date of July 2021, pending any other new executive orders and/or mandates. Discussion occurred concerning potential Brown Act meeting requirements and Cal-OSHA workplace requirements.

**Action:** No action concerning this matter was taken.

**ITEM 6: DISCUSSION AND POSSIBLE ACTION(S) RELATED TO THE PROPOSED PALOMA SQUARE DEVELOPMENT (DOVE CANYON PLAZA) AND OTHER RELATED MATTERS**

Mr. Paludi reported that District staff has not had any contact with the developer or property owner concerning this proposed development since the prior Regular Board Meeting. Mr. Paludi mentioned that a District Property Ad Hoc Committee has been scheduled for the following week. Director Dopudja provided a brief update on certain matters reviewed at the Ad Hoc Committee meeting, and he recommended continuing to agendize this matter for the next few months.

**Action:** No action concerning this matter was taken.

**LEGISLATIVE, ADMINISTRATIVE AND OTHER MATTERS**

**ITEM 7: LOCAL GOVERNMENTAL AND LEGISLATIVE INFORMATIONAL MATTER(S)**

Mr. Paludi provided a brief update on the following items:

- Proposed Brown Act legislation – Mr. Paludi reported that the legislature is currently proposing certain changes to the Brown Act concerning video conferencing for public meetings, and he mentioned that District staff will keep the Board updated on this matter.

**TRABUCO CANYON WATER DISTRICT  
REGULAR BOARD OF DIRECTORS MEETING MINUTES | MAY 19, 2021**

- Statewide Drought Update: Mr. Paludi reported that the Governor has issued a proclamation concerning significant drought conditions in certain parts of the state and has established emergency funds for infrastructure improvements and public messaging.

**Action:** No action concerning this matter was taken.

*Director Chadd left the meeting at 7:49 p.m. Vice President Dopudja assumed the position of Chair.*

**CLOSED SESSION**

Director Mandich recused himself from the agendaized Closed Session. There was no Closed Session due to lack of quorum.

**ITEM 8: REPORT OF ACTION(S) TAKEN IN CLOSED SESSION**

---

There was no need for this agenda item.

**Action:** No announcement concerning this matter was taken.

**OTHER INFORMATION/MATTERS**

There were no other information or matters received.

**ADDITIONAL DIRECTORS' COMMENTS**

None

**ADDITIONAL GENERAL MANAGER COMMENTS**

None

**ADJOURNMENT**

Vice President Dopudja adjourned the May 19, 2021 Regular Board Meeting at 7:53 p.m.

DRAFT



## MINUTES OF THE SPECIAL BOARD MEETING OF THE BOARD OF DIRECTORS OF TRABUCO CANYON WATER DISTRICT | MAY 24, 2021

The Special Meeting of the Board of Directors of the Trabuco Canyon Water District (TCWD) was called to order by President Chadd at 6:00 p.m., in the Board Room at the District Administrative Facility, located at 32003 Dove Canyon Drive, Trabuco Canyon, California. Mr. Michael Perea, District Secretary, transcribed the minutes thereof.

### **DIRECTORS PRESENT**

President Don Chadd  
Vice President Stephen Dopudja  
Director Glenn Acosta  
Director Edward Mandich  
Director Michael Safranski

### **STAFF PRESENT**

Fernando Paludi, General Manager  
Michael Perea, Assistant General Manager  
Lorrie Lausten, Principal Engineer  
Karen Warner, Senior Accountant  
Lisa Sangi, Administrative Assistant

### **DISTRICT CONSULTANTS PRESENT:**

Cindy Byerrum, District Treasurer (Eide Bailly Consulting)

### **PUBLIC PRESENT**

None

### **PLEDGE OF ALLEGIANCE**

Director Acosta led the Board and District staff in the pledge of allegiance.

### **VISITOR PARTICIPATION**

No visitor participation was received.

### **ORAL COMMUNICATION**

No oral communication was received.

### **DIRECTOR'S COMMENTS**

Director Safranski expressed his appreciation for staff efforts to put together the proposed Fiscal Year 2021/2022 Budget materials and to provide to the Board well in advance of the meeting.

Director Acosta briefly reported on his attendance at the Water Advisory Commission of Orange County (WACO) meeting.

**TRABUCO CANYON WATER DISTRICT  
MINUTES OF THE SPECIAL BOARD OF DIRECTORS MEETING | MAY 24, 2021**

**REPORT FROM THE GENERAL MANAGER**

- Mr. Paludi expressed his appreciation to staff for their hard work on the budget materials preparation.
- Mr. Paludi recommended moving agenda item no. 2 to the front of the agenda.

**ACTION CALENDAR**

**ADMINISTRATIVE MATTERS**

**ITEM 2: DISCUSSION AND POSSIBLE ACTION CONCERNING ESTABLISHING A SECTION 115 PENSION TRUST AND FUNDING POLICY**

---

Mr. Paludi introduced this matter for Board consideration, and he reported that the District Treasurer has recommended the District participate in a pension trust for the purpose of reducing past and future pension unfunded actuarial liabilities. Ms. Byerrum reported that District staff requested proposals from and met virtually with two pension trust firms, and she recommended that District contract with CalPERS California Employers' Pension Prefunding Trust (CEPPT) Program. Discussion occurred concerning the most effective manner to fund the pension trust and potential investment liabilities.

**RECOMMENDED ACTION(S):**

A motion was made by Director Acosta and seconded by Director Mandich to:

- 1) Approve the California Employers' Pension Prefunding Trust Program Agreement with CalPERS.
- 2) Approve the Delegation of Authority, appointing the General Manager and Assistant General manager, to administer and request disbursements from the California Employer's Pension Prefunding Trust.
- 3) Approve the California Employers' Pension Prefunding Trust (CEPPT) Certification of Funding Policy.
- 4) Approve an initial funding investment of \$50,000 to develop the CEPPT account and evaluate future contributions in during the budget development process.
- 5) Approve an ADP in \$226,423 in FY 21/22 for the Classic plan to allow for a "Soft Fresh Start" to the 10-year amortization schedule to pay off the Classic plan's UAL.
- 6) Approve an ADP of \$12,978 in FY 21/22 for the PEPRA plan to entirely pay off the PEPRA plan's UAL.

The motion was approved by a vote of 5 – 0. There was no other action on this matter.

**ITEM 1: TRABUCO CANYON WATER DISTRICT FISCAL YEAR 2021/2022 BUDGET WORKSHOP**

---

Mr. Paludi presented this matter for Board consideration, and he delivered a PowerPoint presentation on the District's proposed Fiscal Year 2021/2022 Budget outlines and background supporting information. Mr. Perea provided an organizational update to the Board and highlighted the anticipated personnel changes due to retirement in FY 2021/2022. Director Dopudja recommended an opportunity for the Board of Directors to recognize the retiring employees during the year.

Ms. Lausten provided a comprehensive overview of the proposed Capital Improvement Projects (CIP) and Programmatic budgets for FY 2021/2022. Discussion occurred concerning certain project budgets, goals, and timelines for completion.

Discussion occurred concerning various budgetary considerations related to the presentations. The Board requested additional information be made available as part of further consideration of the proposed organizational changes and budgetary assumptions. Mr. Paludi reported that the proposed FY 2021/2022 General

**TRABUCO CANYON WATER DISTRICT  
MINUTES OF THE SPECIAL BOARD OF DIRECTORS MEETING | MAY 24, 2021**

Fund, CIP, Equipment, and Program budgets will be considered by the Board at the Regular Board meeting scheduled for June 16, 2021.

**RECOMMENDED ACTION(S):**

The Board of Directors received the information. No action was taken.

**END ACTION CALENDAR**

**ADJOURNMENT**

President Chadd adjourned the May 24, 2021 Special Board Meeting – Budget Workshop at 8:02 p.m.

DRAFT

**TRABUCO CANYON WATER DISTRICT  
REGULAR BOARD MEETING | JUNE 16, 2021**

**CONSENT CALENDAR**

**ITEM 2: TREASURER'S REPORT**

---

a. *FINANCE/AUDIT COMMITTEE MEETING*

**RECOMMENDED ACTION:**

*Receive and file the following Finance/Audit Committee Meeting Recap(s):*

1. *May 12, 2021*

b. *PRESENTATION OF FINANCIALS*

**RECOMMENDED ACTION:**

*Receive and file the preliminary statement(s) of revenues and expenses and preliminary unaudited financials for the following month(s):*

1. *April 2021*

c. *PAYMENT OF BILLS FOR CONSIDERATION*

**RECOMMENDED ACTION:**

*Ratify the payment of bills for consideration, Payroll and Payroll Taxes for May 2021.*

**EXHIBITS:**

1. Revenue Report – May 2021
2. Disbursement Report – May 2021
3. Summary of Disbursements – May 2021
4. General Fund Warrant Register – May 2021
5. General Fund Payroll Warrant Register – May 2021

**CONTACTS (staff responsible): PALUDI/PEREA/WARNER**



## TRABUCO CANYON WATER DISTRICT FINANCE/AUDIT COMMITTEE MEETING RECAP | MAY 12, 2021

---

### **DIRECTORS PRESENT VIA CONFERENCE CALL**

Director Don Chadd, Committee Chair  
Director Ed Mandich, Committee Member

### **STAFF PRESENT**

Michael Perea, Assistant General Manager/Board Secretary  
Lorrie Lausten, District Engineer  
Karen Warner, Principal Accountant  
Lisa Marie Sangi, Executive Assistant

### **PUBLIC PRESENT VIA CONFERENCE CALL**

None

### **CALL MEETING TO ORDER**

Director Chadd called the May 12, 2021 Finance/Audit Committee Meeting to order at 4:00 p.m.

### **VISITOR PARTICIPATION**

No visitor participation was received.

### **ORAL COMMUNICATION**

No oral communication was received.

### **COMMITTEE MEMBER COMMENTS**

There were no comments received.

### **REPORT FROM THE ASSISTANT GENERAL MANAGER**

Mr. Perea provided the following report to the Committee:

- Mr. Perea reported that Mr. Paludi was out of the office due to a schedule conflict.
- Mr. Perea updated the Committee that a Special Board Meeting – Budget Workshop has been scheduled for Monday, May 24, 2021 at 6:00 p.m.
- Mr. Perea provided a brief update on the Bureau of Labor Statistics Western Consumer Price Index (CPI) data summary.

### **ITEM 1: FINANCE/AUDIT COMMITTEE MEETING RECAP**

---

Mr. Perea presented the Finance/Audit Committee Meeting Recap for Committee review in accordance with the agenda.

### **RECOMMENDED ACTION:**

The Committee recommended that the Finance/Audit Committee Meeting Recap be forwarded to the Board of Directors for approval (Consent Calendar).

**TRABUCO CANYON WATER DISTRICT  
FINANCE AUDIT COMMITTEE MEETING RECAP | MAY 12, 2021**

**ITEM 2: RATIFICATION OF DIRECTORS' FEES AND EXPENSES, TENTATIVE FUTURE MEETINGS/ATTENDANCE**

---

Mr. Perea presented the Directors' Fees and Expenses Report and Tentative Future Meetings/Attendance Report for Committee consideration and review.

**RECOMMENDED ACTION:**

The Committee recommended that the Directors' Fees and Expenses Report for March 2021 and April 2021, and the Tentative Future Meetings/Attendance Report be forwarded to the Board of Directors for consideration (Action Calendar).

**ITEM 3: OTHER MATTERS**

---

Mr. Perea provided a brief report on the Dimension Water Treatment Plant (DWTP) Backwash Tank Replacement Project and the project timeline and impacts. Ms. Lausten provided additional project-related information, including the DWTP shutdown to accommodate the project work.

**RECOMMENDED ACTION:**

The information was received. No action was taken.

**ITEM 4: FINANCIAL REPORT**

---

Ms. Warner presented the preliminary unaudited financials for March 2021 for Committee consideration and reviewed the following items:

***STATEMENT OF REVENUES AND EXPENSES***

***Operating Revenue, Residential Water***

Ms. Warner reported that this line item was slightly higher than the prior month.

***Operating Revenue, Irrigation Water***

Ms. Warner reported that this line item was higher than the prior month due to less irrigation water usage.

***Operating Revenue, Baker Treatment Plant Water Sales***

Ms. Warner reported that this line item was lower than the prior month due to decreased water sales to the City of San Clemente. Mr. Perea added that the District will likely utilize its Baker Treatment Plant water production during the DWTP Backwash Tank Replacement Project period.

***Operating Expenses, Total Operating Expenses***

Ms. Warner reported that this line item was lower than the prior month due to overall lower expenses and was trending close to budget.

***BALANCE SHEET - COMPARATIVE***

***Utility Plant, at Cost***

Ms. Warner reported that this line item was higher than the prior month due to project costs associated with paving and slurry improvements on the Robinson Ranch Wastewater Treatment Plant access road.

***RESTRICTED ASSETS REPORT & INVESTMENT SCHEDULE***

Ms. Warner highlighted the Local Agency Interest Fund (LAIF) rate of return on District investments.

**TRABUCO CANYON WATER DISTRICT  
FINANCE AUDIT COMMITTEE MEETING RECAP | MAY 12, 2021**

**RECOMMENDED ACTION:**

The Committee signed the bills for consideration and the warrant register and recommended that the Board ratify payment of the bills for consideration for May 12, 2021 as presented (Consent Calendar).

**ADJOURNMENT**

Director Chadd adjourned the May 12, 2021 Finance/Audit Committee Meeting at 4:14 p.m.

DRAFT



# Trabuco Canyon Water District

## Statement of Revenues & Expenses

### FY 2020-21 (Unaudited)

	April 2021	March 2021	Current YTD	Annual Budget	83% YTD	Prior YTD
<b>1 Operating Revenue</b>						
2 Residential Water	\$ 241,523	\$ 226,013	\$ 3,063,984	\$ 3,497,400	88%	\$ 2,659,848
3 Business & Industrial Water	8,403	9,975	127,428	150,300	85%	106,491
4 Irrigation Water	42,581	47,927	784,165	823,400	95%	604,538
5 Stand-by	(5,684)	3,417	25,066	41,000	61%	47,820
6 Sanitation Revenue	151,525	149,500	1,457,729	1,859,400	78%	1,401,351
7 Recycled & Reclaimed Revenue	45,253	35,795	671,492	725,000	93%	591,430
8 Baker Treatment Plant Water Sales *	62,438	116,981	1,068,490	1,469,100	73%	1,055,711
9 Other Operating Revenue	320	281	4,264	164,600	3%	150,209
<b>10 Total Operating Revenue</b>	<b>546,359</b>	<b>589,888</b>	<b>7,202,619</b>	<b>8,730,200</b>	<b>83%</b>	<b>6,617,397</b>
<b>11 Non-Operating Revenue</b>						
12 Property Tax Unrestricted	553,761	142,283	1,834,311	1,707,400	107%	1,800,225
13 Interest Revenue	235	8,348	35,860	100,600	36%	93,285
14 Development Services	-	-	-	-	0%	100
15 Sale of Fixed Asset	-	-	46,158	50,000	92%	-
16 Other Non-Operating Revenue	33,969	2,729	79,708	70,600	113%	58,176
<b>17 Total Non-Operating Revenue</b>	<b>587,965</b>	<b>153,361</b>	<b>1,996,037</b>	<b>1,928,600</b>	<b>103%</b>	<b>1,951,786</b>
<b>18 Total Revenues</b>	<b>1,134,324</b>	<b>743,250</b>	<b>9,198,656</b>	<b>10,658,800</b>	<b>86%</b>	<b>8,569,183</b>
<b>19 Operating Expenses</b>						
20 Source of Supply	177,559	103,518	1,944,682	2,198,100	88%	1,722,211
21 Baker Treatment SOS Costs	-	116,674	888,566	1,155,300	77%	883,196
22 Water Related Expense	118,530	117,441	1,537,562	1,946,900	79%	1,440,254
23 Sanitation Expense	125,799	53,296	1,071,526	1,168,400	92%	1,102,048
24 Recycled Expense	20,137	12,808	187,403	225,300	83%	191,009
25 Reclaimed Expense	20,137	12,810	187,394	221,400	85%	171,126
26 Salaries & Benefits	309,447	324,499	3,016,556	3,684,700	82%	2,865,404
27 OPEB Trust Contributions & Paygo	9,194	9,194	77,503	91,000	85%	73,930
28 Board Expense	6,188	9,879	88,172	114,400	77%	91,571
<b>29 Total Operating Expenses</b>	<b>786,989</b>	<b>760,119</b>	<b>8,999,364</b>	<b>10,805,500</b>	<b>83%</b>	<b>8,540,748</b>
<b>30 Non-Operating Expenses</b>						
31 Principal and Interest Expense	19,198	19,198	191,984	230,300	83%	191,324
32 Non-Operating Expense	8,432	313	12,170	3,600	338%	12,525
<b>33 Total Non-Operating Expenses</b>	<b>27,631</b>	<b>19,511</b>	<b>204,153</b>	<b>233,900</b>	<b>87%</b>	<b>203,849</b>
<b>Net Income (Loss) Before OPEB,</b>						
<b>34 Depreciation &amp; Capital Contributions</b>	<b>319,704</b>	<b>(36,381)</b>	<b>(4,861)</b>	<b>(380,600)</b>	<b>1%</b>	<b>(175,414)</b>
35 WRES Fees for Capital	68,628	68,632	685,241	834,300	82%	697,199
36 Developer Impact Fees	-	19,900	19,900	-	0%	-
37 Other Capital Contributions	99,750	-	99,750	-	0%	1,400,052
<b>38 Total Capital Contributions</b>	<b>168,378</b>	<b>88,532</b>	<b>804,891</b>	<b>834,300</b>	<b>96%</b>	<b>2,097,251</b>
<b>39 Net Income</b>	<b>\$ 488,081</b>	<b>\$ 52,151</b>	<b>\$ 800,030</b>	<b>\$ 453,700</b>	<b>176%</b>	<b>\$ 1,921,837</b>

No assurance is provided on these financial statements. The financial statements do not include a statement of cash flows. Substantially all disclosures required by accounting principles generally accepted in the U.S. are not included.

\*Baker Treatment Plant O&M revenues and expenses are billed quarterly. As a result the % of budget may appear skewed until billing occurs.



## Trabuco Canyon Water District Balance Sheet - Comparative As of April 30, 2021 (Unaudited)

	April 2021	March 2021	April 2020
<b>1 Assets</b>			
<b>2 Current Assets</b>			
3 Cash	\$ 809,415	\$ 273,325	\$ 1,331,790
4 Accounts Receivable, Net	1,985,991	1,914,845	3,974,637
5 Property Tax Receivable	-	429,730	-
6 Prepaid Expenses	164,190	177,172	175,218
<b>7 Total Current Assets</b>	<b>2,959,596</b>	<b>2,795,072</b>	<b>5,481,645</b>
<b>8 Total Restricted Assets (see Schedule A)</b>	<b>7,177,066</b>	<b>7,369,106</b>	<b>4,602,770</b>
<b>9 Utility Plant</b>			
10 Utility Plant, at Cost	116,130,580	116,029,463	114,584,371
11 Accumulated Depreciation	(73,913,643)	(73,611,795)	(71,059,393)
12 Construction in Progress	4,731,056	4,228,893	2,930,830
<b>13 Total Utility Plant</b>	<b>46,947,993</b>	<b>46,646,561</b>	<b>46,455,808</b>
<b>14 Other Assets</b>			
15 Due from BTP	1,150,991	1,182,762	1,527,898
16 Deferred Outflow (Pension Related)	1,179,514	1,179,514	1,126,151
<b>17 Total Other Assets</b>	<b>2,330,505</b>	<b>2,362,276</b>	<b>2,654,049</b>
<b>18 Total Assets</b>	<b>\$ 59,415,159</b>	<b>\$ 59,173,015</b>	<b>\$ 59,194,272</b>
<b>19 Liabilities &amp; Retained Earnings</b>			
<b>20 Current Liabilities</b>			
21 Accounts Payable	\$ 1,289,536	\$ 783,626	\$ 2,234,199
22 Due to Internal Financing Fund	1,150,991	1,182,762	1,527,898
23 Accrued Expenses	467,872	434,568	386,919
24 Deferred Property Tax Revenue	-	437,100	-
<b>25 Total Current Liabilities</b>	<b>2,908,399</b>	<b>2,838,056</b>	<b>4,149,016</b>
<b>26 Liabilities to be Paid from Restricted Assets</b>			
27 Accrued Bond Interest	16,973	12,730	18,316
28 Current Portion-Long Term Debt	178,449	178,449	172,473
29 Refundable Deposits	11,500	9,500	9,500
30 Developer Deposits	74,608	77,108	121,509
<b>31 Total Liabilities to be Paid from Restricted Assets</b>	<b>281,529</b>	<b>277,786</b>	<b>321,799</b>

\*No assurance is provided on these financial statements. Substantially all disclosures required by accounting principles generally accepted in the U.S. are not included.



**Trabuco Canyon Water District**  
**Balance Sheet - Comparative**  
**As of April 30, 2021**  
**(Unaudited)**

32	<b>Long Term Debt</b>			
33	Accrued Post Employment Benefits	533,587	533,587	570,267
34	Accrued Pension Liability	3,301,860	3,301,860	3,089,532
35	State Revolving Fund Loan	2,140,052	2,140,052	2,320,470
36	<b>Total Long Term Debt</b>	<b>5,975,499</b>	<b>5,975,499</b>	<b>5,980,269</b>
37	<b>Total Liabilities</b>	<b>9,165,428</b>	<b>9,091,341</b>	<b>10,451,084</b>
38	<b>Fund Balance</b>			
39	Invested in Capital Net of Related Debt	44,612,519	44,315,331	43,944,549
40	Restricted for Debt Service	237,048	237,041	213,222
41	Legally Restricted	3,424,761	3,613,387	2,115,539
42	Designated by Board	3,402,609	3,402,609	1,296,500
43	Unrestricted	(1,427,205)	(1,486,695)	1,173,378
44	<b>Total Fund Balance</b>	<b>50,249,732</b>	<b>50,081,673</b>	<b>48,743,188</b>
45	<b>Total Liabilities and Fund Balance</b>	<b>\$ 59,415,159</b>	<b>\$ 59,173,015</b>	<b>\$ 59,194,272</b>

\*No assurance is provided on these financial statements. Substantially all disclosures required by accounting principles generally accepted in the U.S. are not included.



**Trabuco Canyon Water District**  
**Restricted Assets Report**  
**As of April 30, 2021**  
**(Unaudited)**

	April 2021	March 2021	April 2020
<b>1 LAIF Accounts (at Cost)</b>			
2 Internal Financing	\$ (1,604,266)	\$ (1,403,026)	\$ (3,154,151)
3 Capital Improvement Charges	-	-	-
4 Water Storage Facilities	1,051,427	1,051,427	1,051,427
5 Sanitation Capital Improvement	-	28,650	488,671
6 WRES - Rose Canyon/Lang Wells	1,282,862	1,246,836	1,090,497
7 WRES - Reservoir/Distribution Improvements	2,618,275	2,613,123	2,563,316
8 RD#5	76,463	76,378	75,779
9 Developer Deposits	-	-	(457,900)
10 LAIF Interim Sewage	112,648	116,068	114,305
11 Water Rate Stabilization Funds	684,080	684,080	607,500
12 Sewer Rate Stabilization Funds	726,160	726,160	265,000
13 Working Capital Funds	1,975,776	1,975,776	1,733,144
14 Market Value Over/(Under) Cost	16,593	16,593	11,960
<b>15 State Revolving Fund</b>			
16 Cash in CB&T Reserved for SRF Loan	237,048	237,041	213,222
<b>17 Total Restricted Assets</b>	<b>\$ 7,177,066</b>	<b>\$ 7,369,106</b>	<b>\$ 4,602,770</b>

\*No assurance is provided on these financial statements. Substantially all disclosures required by accounting principles generally accepted in the U.S. are not included.



**Trabuco Canyon Water District**  
**Investment Schedule**  
**As of April 30, 2021**  
**(Unaudited)**

DESCRIPTION	RATE	COST	MARKET	% OF TOTAL
<b>District Investments in the California Local Agency Investment Fund (LAIF)</b>				
1 Water Storage Fees	0.339%	\$ 1,051,427	\$ 1,052,485	15%
2 Trabuco Creek Wells	0.339%	1,282,862	1,284,153	19%
3 Reservoir/Distribution	0.339%	2,618,275	2,620,911	38%
4 RD#5	0.339%	76,463	76,540	1%
5 LAIF Interim Sewage	0.339%	112,648	112,761	2%
6 Water Rate Stabilization Funds	0.339%	684,080	684,769	10%
7 Sewer Rate Stabilization Funds	0.339%	726,160	726,891	10%
8 Working Capital Funds	0.339%	1,975,776	1,977,765	29%
9 Internal Financing	0.339%	(1,604,266)	(1,605,881)	-23%
<b>Total District Investments</b>		<b>\$ 6,923,425</b>	<b>\$ 6,930,396</b>	<b>100%</b>

*\* A negative number indicates the use of reserves to fund operations.*

*\*\* Market values are adjusted on a quarterly basis and recorded in the District's financials statements at the end of the fiscal year.*

**CERTIFICATION**

I certify that (1) all investment actions executed since the last report have been made in full compliance with the District's Investment Policy and, (2) the District will meet its expenditure obligations for the next six months as required by California Government Code Sections 53646(b)(2) and (3), respectively.

***Cindy Byerrum, CPA***

***Contract CPA and Treasurer***

\*No assurance is provided on these financial statements. Substantially all disclosures required by accounting principles generally accepted in the U.S. are not included.



**Trabuco Canyon Water District**  
**Checking Account Activity**  
**April 2021**  
**(Unaudited)**

<b>Inflows</b>	<b>Current Month</b>	<b>Year to Date</b>
Utility Billing Collections	\$ 544,427	\$ 6,886,281
Tax Receipts	532,274	1,870,946
Transfer From LAIF	200,000	2,000,000
FEMA Reimbursement	-	2,528,981
Miscellaneous	152,672	5,513,655
<b>Total Inflows</b>	<b>1,429,374</b>	<b>18,799,863</b>
<b>Outflows</b>		
Vouchers	401,262	8,561,270
Payroll	244,827	2,525,213
Transfer to LAIF	-	5,500,000
Transfer/payments for State Loan	-	121,191
Miscellaneous & Online Payments	156,386	2,204,005
<b>Total Outflows</b>	<b>802,475</b>	<b>18,911,679</b>
<b>Net Change in Checking Account</b>	626,899	(111,816)
<b>Beginning Checking Account</b>	316,703	1,055,418
<b>Ending Checking Account</b>	<b>\$ 943,602</b>	<b>\$ 943,602</b>

\*No assurance is provided on these financial statements. Substantially all disclosures required by accounting principles generally accepted in the U.S. are not included.



Trabuco Canyon Water District, CA

# Bank Transaction Report

## Transaction Detail

Issued Date Range: 05/01/2021 - 05/31/2021

Cleared Date Range: -

Issued Date	Cleared Date	Number	Description	Module	Status	Type	Amount
<b>Accounts Payable</b>							
<b>Bank Draft</b>							
05/03/2021		<a href="#">DFT0002043</a>	Cintas	Accounts Payable	Outstanding	Bank Draft	-149.12
05/03/2021		<a href="#">DFT0002044</a>	Cintas	Accounts Payable	Outstanding	Bank Draft	-654.81
05/03/2021		<a href="#">DFT0002045</a>	Cintas	Accounts Payable	Outstanding	Bank Draft	-315.00
05/03/2021		<a href="#">DFT0002049</a>	Guardian	Accounts Payable	Outstanding	Bank Draft	-4,470.72
05/03/2021		<a href="#">DFT0002050</a>	EPX	Accounts Payable	Outstanding	Bank Draft	-3,474.04
05/03/2021		<a href="#">DFT0002051</a>	CalPERS	Accounts Payable	Outstanding	Bank Draft	-5,266.36
05/03/2021		<a href="#">DFT0002052</a>	CalPERS	Accounts Payable	Outstanding	Bank Draft	-44,256.70
05/03/2021		<a href="#">DFT0002053</a>	VSP	Accounts Payable	Outstanding	Bank Draft	-906.08
05/03/2021		<a href="#">DFT0002055</a>	Santa Margarita Water District	Accounts Payable	Outstanding	Bank Draft	-1,400.45
05/03/2021		<a href="#">DFT0002058</a>	Santa Margarita Water District	Accounts Payable	Outstanding	Bank Draft	-1,202.20
05/04/2021		<a href="#">DFT0002046</a>	CalPERS	Accounts Payable	Outstanding	Bank Draft	-8,055.68
05/04/2021		<a href="#">DFT0002047</a>	CalPERS	Accounts Payable	Outstanding	Bank Draft	-14,226.35
05/04/2021		<a href="#">DFT0002048</a>	CalPERS	Accounts Payable	Outstanding	Bank Draft	-4,087.21
05/04/2021		<a href="#">DFT0002054</a>	ADP	Accounts Payable	Outstanding	Bank Draft	-97,076.20
05/06/2021		<a href="#">DFT0002056</a>	Verizon Wireless	Accounts Payable	Outstanding	Bank Draft	-1,095.23
05/07/2021		<a href="#">DFT0002059</a>	Lowe's	Accounts Payable	Outstanding	Bank Draft	-108.39
05/07/2021		<a href="#">DFT0002060</a>	Home Depot	Accounts Payable	Outstanding	Bank Draft	-823.64
05/10/2021		<a href="#">DFT0002061</a>	Cox Communications	Accounts Payable	Outstanding	Bank Draft	-2,381.01
05/10/2021		<a href="#">DFT0002062</a>	ADP	Accounts Payable	Outstanding	Bank Draft	-1,882.61
05/10/2021		<a href="#">DFT0002063</a>	The Toll Roads	Accounts Payable	Outstanding	Bank Draft	-140.00
05/11/2021		<a href="#">DFT0002064</a>	South Coast AQMD	Accounts Payable	Outstanding	Bank Draft	-137.63
05/11/2021		<a href="#">DFT0002065</a>	South Coast AQMD	Accounts Payable	Outstanding	Bank Draft	-137.63
05/11/2021		<a href="#">DFT0002066</a>	Exxon/Mobil	Accounts Payable	Outstanding	Bank Draft	-3,532.10
05/11/2021		<a href="#">DFT0002067</a>	Shell Fleet Plus	Accounts Payable	Outstanding	Bank Draft	-1,293.68
05/11/2021		<a href="#">DFT0002068</a>	Shred-it USA LLC	Accounts Payable	Outstanding	Bank Draft	-108.00
05/11/2021		<a href="#">DFT0002069</a>	Umpqua Bank	Accounts Payable	Outstanding	Bank Draft	-11,727.93
05/11/2021		<a href="#">DFT0002070</a>	Home Depot	Accounts Payable	Outstanding	Bank Draft	-816.97
05/11/2021		<a href="#">DFT0002071</a>	Cox Communications	Accounts Payable	Outstanding	Bank Draft	-1,723.84
05/12/2021		<a href="#">DFT0002072</a>	South Coast AQMD	Accounts Payable	Outstanding	Bank Draft	-137.63
05/12/2021		<a href="#">DFT0002073</a>	South Coast AQMD	Accounts Payable	Outstanding	Bank Draft	-137.63
05/12/2021		<a href="#">DFT0002074</a>	South Coast AQMD	Accounts Payable	Outstanding	Bank Draft	-137.63
05/12/2021		<a href="#">DFT0002075</a>	South Coast AQMD	Accounts Payable	Outstanding	Bank Draft	-137.63
05/12/2021		<a href="#">DFT0002076</a>	South Coast AQMD	Accounts Payable	Outstanding	Bank Draft	-137.63
05/12/2021		<a href="#">DFT0002077</a>	South Coast AQMD	Accounts Payable	Outstanding	Bank Draft	-137.63
05/12/2021		<a href="#">DFT0002078</a>	Xerox Corporation	Accounts Payable	Outstanding	Bank Draft	-205.24

**Bank Transaction Report**

Issued Date Range: -

Issued Date	Cleared Date	Number	Description	Module	Status	Type	Amount
05/17/2021		<a href="#">DFT0002079</a>	Cox Communications	Accounts Payable	Outstanding	Bank Draft	-134.82
05/18/2021		<a href="#">DFT0002080</a>	ADP	Accounts Payable	Outstanding	Bank Draft	-310.91
05/19/2021		<a href="#">DFT0002081</a>	ADP	Accounts Payable	Outstanding	Bank Draft	-94,942.14
05/19/2021		<a href="#">DFT0002082</a>	CalPERS	Accounts Payable	Outstanding	Bank Draft	-8,055.68
05/19/2021		<a href="#">DFT0002083</a>	CalPERS	Accounts Payable	Outstanding	Bank Draft	-14,226.35
05/19/2021		<a href="#">DFT0002084</a>	CalPERS	Accounts Payable	Outstanding	Bank Draft	-4,004.15
05/19/2021		<a href="#">DFT0002085</a>	The Toll Roads	Accounts Payable	Outstanding	Bank Draft	-140.00
05/20/2021		<a href="#">DFT0002086</a>	Cox Communications	Accounts Payable	Outstanding	Bank Draft	-689.96
05/20/2021		<a href="#">DFT0002087</a>	AT&T Mobility	Accounts Payable	Outstanding	Bank Draft	-36,118.97
05/25/2021		<a href="#">DFT0002089</a>	ADP	Accounts Payable	Outstanding	Bank Draft	-74.71
05/26/2021		<a href="#">DFT0002088</a>	Southern California Edison	Accounts Payable	Outstanding	Bank Draft	-26,911.70
05/27/2021		<a href="#">DFT0002090</a>	Stanley Security Solutions	Accounts Payable	Outstanding	Bank Draft	-1,899.21
05/28/2021		<a href="#">DFT0002091</a>	ADP	Accounts Payable	Outstanding	Bank Draft	-120.00
<b>Bank Draft Total: (48)</b>							<b>-400,109.20</b>
<b>Bank Draft Reversal</b>							
05/03/2021		<a href="#">DFT0002055</a>	Santa Margarita Water District Reversal	Accounts Payable	Outstanding	Bank Draft Reversal	1,400.45
<b>Bank Draft Reversal Total: (1)</b>							<b>1,400.45</b>
<b>Check</b>							
05/07/2021		<a href="#">10081</a>	ALS - Truesdail Laboratories	Accounts Payable	Outstanding	Check	-1,873.00
05/07/2021		<a href="#">10082</a>	ARC	Accounts Payable	Outstanding	Check	-1,120.29
05/07/2021		<a href="#">10083</a>	Butier Engineering, Inc.	Accounts Payable	Outstanding	Check	-8,150.00
05/07/2021		<a href="#">10084</a>	Chemtrade Chemicals US LLC	Accounts Payable	Outstanding	Check	-4,558.30
05/07/2021		<a href="#">10085</a>	Department of Water Resources	Accounts Payable	Outstanding	Check	-38,097.00
05/07/2021		<a href="#">10086</a>	Dove Canyon Masters Association	Accounts Payable	Outstanding	Check	-678.00
05/07/2021		<a href="#">10087</a>	Ferreira Construction Company	Accounts Payable	Outstanding	Check	-24,221.65
05/07/2021		<a href="#">10088</a>	Harrington Industrial Plastics	Accounts Payable	Outstanding	Check	-207.29
05/07/2021		<a href="#">10089</a>	JIG Consultants	Accounts Payable	Outstanding	Check	-3,680.00
05/07/2021		<a href="#">10090</a>	Michael K. Nunley & Associates	Accounts Payable	Outstanding	Check	-4,491.57
05/07/2021		<a href="#">10091</a>	Olin Chemicals	Accounts Payable	Outstanding	Check	-4,240.32
05/07/2021		<a href="#">10092</a>	Orange County Pumping, Inc.	Accounts Payable	Outstanding	Check	-2,485.00
05/07/2021		<a href="#">10093</a>	O'Reilly Automotive, Inc.	Accounts Payable	Outstanding	Check	-91.91
05/07/2021		<a href="#">10094</a>	Project Partners, Inc.	Accounts Payable	Outstanding	Check	-4,420.00
05/07/2021		<a href="#">10095</a>	S & J Supply Company	Accounts Payable	Outstanding	Check	-292.39
05/07/2021		<a href="#">10096</a>	Sierra Springs	Accounts Payable	Outstanding	Check	-90.75
05/07/2021		<a href="#">10097</a>	USABlueBook	Accounts Payable	Outstanding	Check	-390.77
05/07/2021		<a href="#">10098</a>	Weck Laboratories, Inc.	Accounts Payable	Outstanding	Check	-110.80
05/10/2021		<a href="#">10099</a>	Premier Mail Marketing	Accounts Payable	Outstanding	Check	-923.28
05/11/2021		<a href="#">10100</a>	BAVCO Backflow Apparatus & Valve Co.	Accounts Payable	Outstanding	Check	-26.28
05/11/2021		<a href="#">10101</a>	Comoso	Accounts Payable	Outstanding	Check	-2,486.89
05/11/2021		<a href="#">10102</a>	Dunn-Edwards Corporation	Accounts Payable	Outstanding	Check	-150.35
05/11/2021		<a href="#">10103</a>	Duthie Electric Service Corporation	Accounts Payable	Outstanding	Check	-5,275.00
05/11/2021		<a href="#">10104</a>	Eagle Communications	Accounts Payable	Outstanding	Check	-1,086.48

**Bank Transaction Report**

**Issued Date Range: -**

Issued Date	Cleared Date	Number	Description	Module	Status	Type	Amount
05/11/2021		<a href="#">10105</a>	Ferreira Construction Company	Accounts Payable	Outstanding	Check	-467,746.50
05/11/2021		<a href="#">10106</a>	Hydrotech Electric	Accounts Payable	Outstanding	Check	-13,927.53
05/11/2021		<a href="#">10107</a>	Irvine Ranch Water District	Accounts Payable	Outstanding	Check	-18,484.71
05/11/2021		<a href="#">10108</a>	JRT ROOFING AND WATERPROOFING	Accounts Payable	Outstanding	Check	-32,390.00
05/11/2021		<a href="#">10109</a>	Material Specialties Corp.	Accounts Payable	Outstanding	Check	-2,071.04
05/11/2021		<a href="#">10110</a>	McFadden-Dale Industrial Hardware	Accounts Payable	Outstanding	Check	-398.04
05/11/2021		<a href="#">10111</a>	Michael K. Nunley & Associates	Accounts Payable	Outstanding	Check	-2,522.98
05/11/2021		<a href="#">10112</a>	Napa Auto Parts	Accounts Payable	Outstanding	Check	-938.46
05/11/2021		<a href="#">10113</a>	Olin Chemicals	Accounts Payable	Outstanding	Check	-2,133.90
05/11/2021		<a href="#">10114</a>	Orange County Pumping, Inc.	Accounts Payable	Outstanding	Check	-1,065.00
05/11/2021		<a href="#">10115</a>	Quinn Company	Accounts Payable	Outstanding	Check	-1,461.08
05/11/2021		<a href="#">10116</a>	Santa Margarita Water District	Accounts Payable	Outstanding	Check	-660.00
05/11/2021		<a href="#">10117</a>	Shelton Fire Protection Co., Inc.	Accounts Payable	Outstanding	Check	-3,010.00
05/11/2021		<a href="#">10118</a>	Stadia Realty, Inc	Accounts Payable	Outstanding	Check	-6,400.00
05/11/2021		<a href="#">10119</a>	Tekdraulics	Accounts Payable	Outstanding	Check	-1,379.20
05/11/2021		<a href="#">10120</a>	Touch Tel Mobile	Accounts Payable	Outstanding	Check	-625.00
05/11/2021		<a href="#">10121</a>	TrucParCo	Accounts Payable	Outstanding	Check	-817.52
05/11/2021		<a href="#">10122</a>	Underground Service Alert/SC	Accounts Payable	Outstanding	Check	-128.74
05/11/2021		<a href="#">10123</a>	United Pumping Service, Inc.	Accounts Payable	Outstanding	Check	-6,631.35
05/11/2021		<a href="#">10124</a>	USA Express Tire & Service	Accounts Payable	Outstanding	Check	-127.00
05/11/2021		<a href="#">10125</a>	USABlueBook	Accounts Payable	Outstanding	Check	-180.98
05/11/2021		<a href="#">10126</a>	Vituity - Urgent Care Services	Accounts Payable	Outstanding	Check	-588.00
05/11/2021		<a href="#">10127</a>	West Marine Products Inc.	Accounts Payable	Outstanding	Check	-158.37
05/25/2021		<a href="#">10128</a>	State Water Resources Control Board	Accounts Payable	Outstanding	Check	-170.00
05/25/2021		<a href="#">10129</a>	Tuttle-Click Ford	Accounts Payable	Outstanding	Check	-40,338.69
						<b>Check Total: (49)</b>	<b>-713,501.41</b>
<b>EFT</b>							
05/07/2021		<a href="#">45</a>	MWDOC	Accounts Payable	Outstanding	EFT	-81,436.06
05/07/2021		<a href="#">46</a>	United Water Works, Inc.	Accounts Payable	Outstanding	EFT	-152.11
05/11/2021		<a href="#">47</a>	Synoptek, LLC	Accounts Payable	Outstanding	EFT	-551.00
05/11/2021		<a href="#">48</a>	United Water Works, Inc.	Accounts Payable	Outstanding	EFT	-126.59
						<b>EFT Total: (4)</b>	<b>-82,265.76</b>
						<b>Accounts Payable Total: (102)</b>	<b>-1,194,475.92</b>

**General Ledger**

<b>Deposit</b>							
Issued Date	Cleared Date	Number	Description	Module	Status	Type	Amount
05/06/2021		<a href="#">DEP0013378</a>	Receipts - Rutter - Ridgeline BPS	General Ledger	Outstanding	Deposit	506,805.00
05/06/2021		<a href="#">DEP0013379</a>	Receipts - City of SC - BTP Qtrly	General Ledger	Outstanding	Deposit	117,243.52
05/06/2021		<a href="#">DEP0013380</a>	Receipts - Rias - Reimburse TCWD	General Ledger	Outstanding	Deposit	3.99
05/06/2021		<a href="#">DEP0013381</a>	Receipts - County of Orange - Property Taxes	General Ledger	Outstanding	Deposit	2,787.58
05/13/2021		<a href="#">DEP0013440</a>	Receipts - County of Orange - Property Taxes	General Ledger	Outstanding	Deposit	5,874.50
05/19/2021		<a href="#">DEP0013553</a>	Receipts - County of Orange - Sewer Services	General Ledger	Outstanding	Deposit	4,270.00
05/19/2021		<a href="#">DEP0013554</a>	Receipts - T-Mobile - Cell site rent	General Ledger	Outstanding	Deposit	2,069.63

**Bank Transaction Report**

**Issued Date Range: -**

Issued Date	Cleared Date	Number	Description	Module	Status	Type	Amount
05/19/2021		<a href="#">DEP0013555</a>	Receipts - Monson - PERS Loan Repayment	General Ledger	Outstanding	Deposit	286.98
05/19/2021		<a href="#">DEP0013556</a>	Receipts - Wholesale Plumbing - Settlement Agreement	General Ledger	Outstanding	Deposit	67.85
05/20/2021		<a href="#">DEP0013557</a>	Receipts - County of Orange - Property Taxes	General Ledger	Outstanding	Deposit	43,280.99
05/21/2021		<a href="#">DEP0013565</a>	Receipts - County of Orange - Property Taxes	General Ledger	Outstanding	Deposit	10,532.53
05/27/2021		<a href="#">DEP0013638</a>	Receipts - 1st Commercial Realty - Trabuco Marketplace	General Ledger	Outstanding	Deposit	2,000.00
05/27/2021		<a href="#">DEP0013644</a>	Receipts - County of Orange - Property Taxes	General Ledger	Outstanding	Deposit	118,056.41
<b>Deposit Total: (13)</b>							<b>813,278.98</b>
<b>General Ledger Total: (13)</b>							<b>813,278.98</b>

**Utility Billing**

Check	Number	Description	Module	Status	Type	Amount
05/27/2021	<a href="#">10130</a>	ISABEL TEJERAS	Utility Billing	Outstanding	Check	-36.33
05/27/2021	<a href="#">10131</a>	RJ NOBLE	Utility Billing	Outstanding	Check	-868.51
05/27/2021	<a href="#">10132</a>	JOSHUA GRADING & EXCAVATING	Utility Billing	Outstanding	Check	-1,883.56
<b>Check Total: (3)</b>						<b>-2,788.40</b>

**Deposit**

05/01/2021	<a href="#">DEP0013329</a>	Utility Payment Packet UBPKT05685	Utility Billing	Outstanding	Deposit	1,590.19
05/02/2021	<a href="#">DEP0013331</a>	Utility Payment Packet UBPKT05686	Utility Billing	Outstanding	Deposit	1,297.85
05/03/2021	<a href="#">DEP0013333</a>	Utility Payment Packet UBPKT05688	Utility Billing	Outstanding	Deposit	2,883.19
05/03/2021	<a href="#">DEP0013335</a>	Utility Payment Packet UBPKT05687	Utility Billing	Outstanding	Deposit	1,519.82
05/03/2021	<a href="#">DEP0013338</a>	Utility Payment Packet UBPKT05689	Utility Billing	Outstanding	Deposit	5,274.19
05/04/2021	<a href="#">DEP0013342</a>	Utility Payment Packet UBPKT05691	Utility Billing	Outstanding	Deposit	2,733.62
05/04/2021	<a href="#">DEP0013344</a>	Utility Payment Packet UBPKT05690	Utility Billing	Outstanding	Deposit	2,326.91
05/04/2021	<a href="#">DEP0013350</a>	Utility Payment Packet UBPKT05692	Utility Billing	Outstanding	Deposit	4,006.29
05/04/2021	<a href="#">DEP0013352</a>	Utility Payment Packet UBPKT05693	Utility Billing	Outstanding	Deposit	3,802.97
05/04/2021	<a href="#">DEP0013354</a>	Utility Payment Packet UBPKT05694	Utility Billing	Outstanding	Deposit	4,164.88
05/04/2021	<a href="#">DEP0013356</a>	Utility Payment Packet UBPKT05695	Utility Billing	Outstanding	Deposit	4,341.64
05/04/2021	<a href="#">DEP0013359</a>	Utility Payment Packet UBPKT05697	Utility Billing	Outstanding	Deposit	2,470.53
05/05/2021	<a href="#">DEP0013363</a>	Utility Payment Packet UBPKT05699	Utility Billing	Outstanding	Deposit	1,987.81
05/05/2021	<a href="#">DEP0013365</a>	Utility Payment Packet UBPKT05698	Utility Billing	Outstanding	Deposit	4,829.14
05/05/2021	<a href="#">DEP0013368</a>	Utility Payment Packet UBPKT05700	Utility Billing	Outstanding	Deposit	2,446.89
05/06/2021	<a href="#">DEP0013372</a>	Utility Payment Packet UBPKT05702	Utility Billing	Outstanding	Deposit	1,554.30
05/06/2021	<a href="#">DEP0013374</a>	Utility Payment Packet UBPKT05701	Utility Billing	Outstanding	Deposit	4,127.37
05/06/2021	<a href="#">DEP0013377</a>	Utility Reverse Payment Packet UBPKT05705	Utility Billing	Outstanding	Deposit	-96.88
05/06/2021	<a href="#">DEP0013384</a>	Utility Payment Packet UBPKT05706	Utility Billing	Outstanding	Deposit	6,253.71
05/07/2021	<a href="#">DEP0013388</a>	Utility Payment Packet UBPKT05708	Utility Billing	Outstanding	Deposit	3,900.64
05/07/2021	<a href="#">DEP0013390</a>	Utility Payment Packet UBPKT05707	Utility Billing	Outstanding	Deposit	1,721.26
05/07/2021	<a href="#">DEP0013393</a>	Utility Payment Packet UBPKT05709	Utility Billing	Outstanding	Deposit	3,104.51
05/08/2021	<a href="#">DEP0013403</a>	Utility Payment Packet UBPKT05710	Utility Billing	Outstanding	Deposit	2,175.58
05/09/2021	<a href="#">DEP0013405</a>	Utility Payment Packet UBPKT05711	Utility Billing	Outstanding	Deposit	780.19
05/10/2021	<a href="#">DEP0013399</a>	Utility Payment Packet UBPKT05713	Utility Billing	Outstanding	Deposit	2,527.48
05/10/2021	<a href="#">DEP0013401</a>	Utility Payment Packet UBPKT05712	Utility Billing	Outstanding	Deposit	2,421.79
05/10/2021	<a href="#">DEP0013408</a>	Utility Payment Packet UBPKT05714	Utility Billing	Outstanding	Deposit	6,925.32

**Bank Transaction Report**

**Issued Date Range: -**

Issued Date	Cleared Date	Number	Description	Module	Status	Type	Amount
05/11/2021		<a href="#">DEP0013417</a>	Utility Payment Packet UBPKT05716	Utility Billing	Outstanding	Deposit	2,152.56
05/11/2021		<a href="#">DEP0013419</a>	Utility Payment Packet UBPKT05715	Utility Billing	Outstanding	Deposit	2,065.37
05/11/2021		<a href="#">DEP0013421</a>	Utility Payment Packet UBPKT05717	Utility Billing	Outstanding	Deposit	3,685.08
05/11/2021		<a href="#">DEP0013423</a>	Utility Payment Packet UBPKT05718	Utility Billing	Outstanding	Deposit	3,507.46
05/11/2021		<a href="#">DEP0013425</a>	Utility Payment Packet UBPKT05719	Utility Billing	Outstanding	Deposit	2,242.19
05/11/2021		<a href="#">DEP0013427</a>	Utility Payment Packet UBPKT05720	Utility Billing	Outstanding	Deposit	2,379.99
05/11/2021		<a href="#">DEP0013429</a>	Utility Payment Packet UBPKT05721	Utility Billing	Outstanding	Deposit	2,000.78
05/11/2021		<a href="#">DEP0013433</a>	Utility Payment Packet UBPKT05722	Utility Billing	Outstanding	Deposit	98,918.25
05/12/2021		<a href="#">DEP0013437</a>	Utility Payment Packet UBPKT05724	Utility Billing	Outstanding	Deposit	4,715.17
05/12/2021		<a href="#">DEP0013439</a>	Utility Payment Packet UBPKT05723	Utility Billing	Outstanding	Deposit	4,025.18
05/12/2021		<a href="#">DEP0013443</a>	Utility Payment Packet UBPKT05725	Utility Billing	Outstanding	Deposit	5,857.18
05/13/2021		<a href="#">DEP0013447</a>	Utility Payment Packet UBPKT05727	Utility Billing	Outstanding	Deposit	2,267.82
05/13/2021		<a href="#">DEP0013449</a>	Utility Payment Packet UBPKT05726	Utility Billing	Outstanding	Deposit	3,171.95
05/13/2021		<a href="#">DEP0013452</a>	Utility Payment Packet UBPKT05728	Utility Billing	Outstanding	Deposit	2,673.38
05/13/2021		<a href="#">DEP0013457</a>	Utility Payment Packet UBPKT05730	Utility Billing	Outstanding	Deposit	3,134.30
05/13/2021		<a href="#">DEP0013459</a>	Utility Payment Packet UBPKT05731	Utility Billing	Outstanding	Deposit	10,292.60
05/13/2021		<a href="#">DEP0013461</a>	Utility Payment Packet UBPKT05732	Utility Billing	Outstanding	Deposit	1,253.89
05/13/2021		<a href="#">DEP0013464</a>	Utility Payment Packet UBPKT05733	Utility Billing	Outstanding	Deposit	7,974.83
05/14/2021		<a href="#">DEP0013468</a>	Utility Payment Packet UBPKT05735	Utility Billing	Outstanding	Deposit	9,149.18
05/14/2021		<a href="#">DEP0013470</a>	Utility Payment Packet UBPKT05734	Utility Billing	Outstanding	Deposit	4,123.54
05/14/2021		<a href="#">DEP0013474</a>	Utility Reverse Payment Packet UBPKT05739	Utility Billing	Outstanding	Deposit	-24.47
05/14/2021		<a href="#">DEP0013476</a>	ACH Draft Packet UBPKT05610	Utility Billing	Outstanding	Deposit	84,716.37
05/14/2021		<a href="#">DEP0013479</a>	Utility Payment Packet UBPKT05767	Utility Billing	Outstanding	Deposit	18,127.83
05/15/2021		<a href="#">DEP0013488</a>	Utility Payment Packet UBPKT05768	Utility Billing	Outstanding	Deposit	1,654.39
05/16/2021		<a href="#">DEP0013490</a>	Utility Payment Packet UBPKT05769	Utility Billing	Outstanding	Deposit	1,217.68
05/17/2021		<a href="#">DEP0013492</a>	Utility Payment Packet UBPKT05770	Utility Billing	Outstanding	Deposit	4,199.96
05/17/2021		<a href="#">DEP0013494</a>	Utility Payment Packet UBPKT05771	Utility Billing	Outstanding	Deposit	560.86
05/17/2021		<a href="#">DEP0013496</a>	Utility Payment Packet UBPKT05772	Utility Billing	Outstanding	Deposit	1,915.86
05/17/2021		<a href="#">DEP0013498</a>	Utility Payment Packet UBPKT05773	Utility Billing	Outstanding	Deposit	684.00
05/17/2021		<a href="#">DEP0013500</a>	Utility Payment Packet UBPKT05774	Utility Billing	Outstanding	Deposit	1,075.01
05/17/2021		<a href="#">DEP0013504</a>	Utility Payment Packet UBPKT05781	Utility Billing	Outstanding	Deposit	1,877.14
05/18/2021		<a href="#">DEP0013507</a>	Utility Payment Packet UBPKT05782	Utility Billing	Outstanding	Deposit	791.79
05/18/2021		<a href="#">DEP0013510</a>	Utility Payment Packet UBPKT05784	Utility Billing	Outstanding	Deposit	2,574.62
05/19/2021		<a href="#">DEP0013514</a>	Utility Payment Packet UBPKT05786	Utility Billing	Outstanding	Deposit	394.11
05/19/2021		<a href="#">DEP0013516</a>	Utility Payment Packet UBPKT05785	Utility Billing	Outstanding	Deposit	1,193.27
05/19/2021		<a href="#">DEP0013520</a>	Utility Payment Packet UBPKT05787	Utility Billing	Outstanding	Deposit	1,465.61
05/19/2021		<a href="#">DEP0013522</a>	Utility Payment Packet UBPKT05788	Utility Billing	Outstanding	Deposit	1,260.61
05/19/2021		<a href="#">DEP0013534</a>	Utility Payment Packet UBPKT05795	Utility Billing	Outstanding	Deposit	1,021.89
05/20/2021		<a href="#">DEP0013538</a>	Utility Payment Packet UBPKT05797	Utility Billing	Outstanding	Deposit	125.00
05/20/2021		<a href="#">DEP0013540</a>	Utility Payment Packet UBPKT05796	Utility Billing	Outstanding	Deposit	322.54
05/20/2021		<a href="#">DEP0013543</a>	Utility Payment Packet UBPKT05801	Utility Billing	Outstanding	Deposit	14,786.24
05/21/2021		<a href="#">DEP0013547</a>	Utility Payment Packet UBPKT05803	Utility Billing	Outstanding	Deposit	748.92
05/21/2021		<a href="#">DEP0013549</a>	Utility Payment Packet UBPKT05802	Utility Billing	Outstanding	Deposit	216.70

**Bank Transaction Report**

**Issued Date Range: -**

Issued Date	Cleared Date	Number	Description	Module	Status	Type	Amount
05/21/2021		<a href="#">DEP0013552</a>	Utility Reverse Payment Packet UBPKT05804	Utility Billing	Outstanding	Deposit	-38.51
05/21/2021		<a href="#">DEP0013560</a>	Utility Payment Packet UBPKT05808	Utility Billing	Outstanding	Deposit	6,172.38
05/22/2021		<a href="#">DEP0013567</a>	Utility Payment Packet UBPKT05809	Utility Billing	Outstanding	Deposit	3,173.45
05/23/2021		<a href="#">DEP0013569</a>	Utility Payment Packet UBPKT05810	Utility Billing	Outstanding	Deposit	1,133.78
05/24/2021		<a href="#">DEP0013571</a>	Utility Payment Packet UBPKT05811	Utility Billing	Outstanding	Deposit	189.44
05/24/2021		<a href="#">DEP0013573</a>	Utility Payment Packet UBPKT05812	Utility Billing	Outstanding	Deposit	2,566.59
05/24/2021		<a href="#">DEP0013578</a>	Utility Payment Packet UBPKT05816	Utility Billing	Outstanding	Deposit	3,823.13
05/24/2021		<a href="#">DEP0013580</a>	Utility Payment Packet UBPKT05817	Utility Billing	Outstanding	Deposit	1,558.07
05/24/2021		<a href="#">DEP0013582</a>	Utility Payment Packet UBPKT05818	Utility Billing	Outstanding	Deposit	4,846.87
05/24/2021		<a href="#">DEP0013585</a>	Utility Payment Packet UBPKT05819	Utility Billing	Outstanding	Deposit	3,082.50
05/25/2021		<a href="#">DEP0013589</a>	Utility Payment Packet UBPKT05821	Utility Billing	Outstanding	Deposit	7,805.54
05/25/2021		<a href="#">DEP0013591</a>	Utility Payment Packet UBPKT05820	Utility Billing	Outstanding	Deposit	2,493.09
05/25/2021		<a href="#">DEP0013594</a>	Utility Reverse Payment Packet UBPKT05822	Utility Billing	Outstanding	Deposit	-121.07
05/25/2021		<a href="#">DEP0013597</a>	Utility Payment Packet UBPKT05823	Utility Billing	Outstanding	Deposit	1,939.21
05/26/2021		<a href="#">DEP0013601</a>	Utility Payment Packet UBPKT05825	Utility Billing	Outstanding	Deposit	2,880.82
05/26/2021		<a href="#">DEP0013603</a>	Utility Payment Packet UBPKT05824	Utility Billing	Outstanding	Deposit	7,469.97
05/26/2021		<a href="#">DEP0013608</a>	Utility Payment Packet UBPKT05828	Utility Billing	Outstanding	Deposit	5,487.72
05/26/2021		<a href="#">DEP0013610</a>	Utility Payment Packet UBPKT05829	Utility Billing	Outstanding	Deposit	2,968.45
05/26/2021		<a href="#">DEP0013612</a>	Utility Payment Packet UBPKT05830	Utility Billing	Outstanding	Deposit	2,188.91
05/26/2021		<a href="#">DEP0013618</a>	Utility Payment Packet UBPKT05835	Utility Billing	Outstanding	Deposit	2,054.05
05/27/2021		<a href="#">DEP0013622</a>	Utility Payment Packet UBPKT05837	Utility Billing	Outstanding	Deposit	1,646.10
05/27/2021		<a href="#">DEP0013624</a>	Utility Payment Packet UBPKT05836	Utility Billing	Outstanding	Deposit	7,040.70
05/27/2021		<a href="#">DEP0013629</a>	Utility Payment Packet UBPKT05838	Utility Billing	Outstanding	Deposit	2,541.24
05/27/2021		<a href="#">DEP0013631</a>	Utility Payment Packet UBPKT05839	Utility Billing	Outstanding	Deposit	2,133.83
05/27/2021		<a href="#">DEP0013633</a>	Utility Payment Packet UBPKT05840	Utility Billing	Outstanding	Deposit	2,894.33
05/27/2021		<a href="#">DEP0013636</a>	Utility Payment Packet UBPKT05841	Utility Billing	Outstanding	Deposit	11,429.37
05/28/2021		<a href="#">DEP0013641</a>	Utility Payment Packet UBPKT05843	Utility Billing	Outstanding	Deposit	2,796.90
05/28/2021		<a href="#">DEP0013643</a>	Utility Payment Packet UBPKT05842	Utility Billing	Outstanding	Deposit	2,863.14
05/28/2021		<a href="#">DEP0013647</a>	Utility Payment Packet UBPKT05844	Utility Billing	Outstanding	Deposit	9,298.43
05/29/2021		<a href="#">DEP0013650</a>	Utility Payment Packet UBPKT05845	Utility Billing	Outstanding	Deposit	1,570.93
05/30/2021		<a href="#">DEP0013653</a>	Utility Payment Packet UBPKT05846	Utility Billing	Outstanding	Deposit	1,228.80
05/31/2021		<a href="#">DEP0013656</a>	Utility Payment Packet UBPKT05847	Utility Billing	Outstanding	Deposit	1,262.36
<b>Deposit Total: (102)</b>							<b>505,948.34</b>
<b>Utility Billing Total: (105)</b>							<b>503,159.94</b>
<b>Report Total: (220)</b>							<b>121,963.00</b>

**Summary**

Bank Account	Count	Amount
<a href="#">030866939 Bank of the West Checking</a>	220	121,963.00
<b>Report Total:</b>	<b>220</b>	<b>121,963.00</b>

Cash Account	Count	Amount
<a href="#">99 99-000-1004 Bank of the West Checking (Pooled Cash)</a>	220	121,963.00
<b>Report Total:</b>	<b>220</b>	<b>121,963.00</b>

Transaction Type	Count	Amount
Bank Draft	48	-400,109.20
Bank Draft Reversal	1	1,400.45
Check	52	-716,289.81
Deposit	115	1,319,227.32
EFT	4	-82,265.76
<b>Report Total:</b>	<b>220</b>	<b>121,963.00</b>



Trabuco Canyon Water District  
General Fund Warrant Register  
5/12/2021

**Summary of Disbursements**

Computer Checks	1,009,554.95
UB Refund Checks	11,356.29
Bank Drafts	354,164.44
Bank EFTs	108,080.04
Voided Checks	(394.00)
<b>Total Disbursements</b>	<b>1,482,761.72</b>

I hereby certify that the claims or demands covered by the above listed warrants have been audited as to accuracy and the availability of funds for payment thereof; and that the said claims or demands are accurate and that the funds are available.

\_\_\_\_\_  
General Manager / Assistant General Manager

This is to certify that claims or demands covered by the above listed warrants have been audited by the Finance/Audit Committee of the Trabuco Canyon Water District and that all of the said warrants are approved for payment.

Donald S. Chadd  
Donald S. Chadd (May 13, 2021 16:44 PDT)

\_\_\_\_\_  
By: \_\_\_\_\_ Date: \_\_\_\_\_

Ed Mandich  
Ed Mandich (May 13, 2021 17:26 PDT)

\_\_\_\_\_  
By: \_\_\_\_\_ Date: \_\_\_\_\_



Trabuco Canyon Water District, CA

# Check Report

By Check Number

Date Range: 04/14/2021 - 05/12/2021

Vendor Number	Vendor Name	Payment Date	Payment Type	Discount Amount	Payment Amount	Number
<b>Bank Code: APBNK-APBNK</b>						
ACWA0002	ACWA/JPIA	04/20/2021	EFT	0.00	712.61	39
SYNO0001	Synoptek, LLC	04/20/2021	EFT	0.00	4,798.35	40
UNIT0001	United Water Works, Inc.	04/20/2021	EFT	0.00	516.45	41
ACWA0002	ACWA/JPIA	04/26/2021	EFT	0.00	13,877.86	42
EIDE0001	Eide Bailly	04/26/2021	EFT	0.00	5,240.00	43
UNIT0001	United Water Works, Inc.	04/26/2021	EFT	0.00	669.01	44
MWDO0001	MWDOC	05/07/2021	EFT	0.00	81,436.06	45
UNIT0001	United Water Works, Inc.	05/07/2021	EFT	0.00	152.11	46
SYNO0001	Synoptek, LLC	05/11/2021	EFT	0.00	551.00	47
UNIT0001	United Water Works, Inc.	05/11/2021	EFT	0.00	126.59	48
RUED0001	Ana C. Noriega Rueda	04/30/2021	Regular	0.00	-394.00	9691
TUTT0001	Tuttle-Click Ford	04/14/2021	Regular	0.00	38,351.59	10023
TUTT0001	Tuttle-Click Ford	04/14/2021	Regular	0.00	38,631.74	10024
TRUE0001	ALS - Truesdail Laboratories	04/20/2021	Regular	0.00	1,486.50	10025
BAVCO001	BAVCO Backflow Apparatus & Valve Co.	04/20/2021	Regular	0.00	642.63	10026
BLAC0001	Black Knight Financial Services, LLC	04/20/2021	Regular	0.00	4.50	10027
CMCR0001	CM Crane & Training Services	04/20/2021	Regular	0.00	16,620.00	10028
CUST0002	Custom Lock & Key	04/20/2021	Regular	0.00	118.12	10029
DCFR0001	DC Frost Associates, Inc.	04/20/2021	Regular	0.00	4,217.69	10030
DUTH0001	Duthie Electric Service Corporation	04/20/2021	Regular	0.00	215.21	10031
FERR0002	Ferreira Construction Company	04/20/2021	Regular	0.00	20,860.73	10032
FLEE0001	Fleet Services, Inc. - Anaheim	04/20/2021	Regular	0.00	1,940.52	10033
HARR0001	Harrington Industrial Plastics	04/20/2021	Regular	0.00	1,313.03	10034
INDU0002	Industrial Metal Supply Company	04/20/2021	Regular	0.00	628.09	10035
INFO0001	InfoSend, Inc.	04/20/2021	Regular	0.00	2,429.57	10036
IRVI0002	Irvine Pipe Supply	04/20/2021	Regular	0.00	516.44	10037
IRVI0001	Irvine Ranch Water District	04/20/2021	Regular	0.00	17,635.51	10038
MISS0001	Mission Paving and Sealing, Inc.	04/20/2021	Regular	0.00	17,400.00	10039
OCSU0001	OC Superior Cleaning Services	04/20/2021	Regular	0.00	735.00	10040
OLIN0001	Olin Chemicals	04/20/2021	Regular	0.00	1,292.03	10041
ORAN0004	Orange County Pumping, Inc.	04/20/2021	Regular	0.00	1,420.00	10042
PRAX0001	Praxair Distribution Inc	04/20/2021	Regular	0.00	105.95	10043
S&JS0001	S & J Supply Company	04/20/2021	Regular	0.00	898.81	10044
SANT0003	Santa Margarita Water District	04/20/2021	Regular	0.00	3,168.00	10045
SIER0001	Sierra Springs	04/20/2021	Regular	0.00	28.75	10046
SOUT0009	SouthWest Hydro Tech ACV Systems	04/20/2021	Regular	0.00	540.00	10047
STAT0001	State Water Resources Control Board	04/20/2021	Regular	0.00	110.00	10048
TABA0001	TAB AnswerNetwork	04/20/2021	Regular	0.00	157.14	10049
Trab0002	Trabuco Highlands Community Assoc.	04/20/2021	Regular	0.00	1,826.50	10050
TRUC0001	TrucParCo	04/20/2021	Regular	0.00	1,447.14	10051
TYLE0001	Tyler Technologies, Inc.	04/20/2021	Regular	0.00	37.40	10052
UNDE0001	Underground Service Alert/SC	04/20/2021	Regular	0.00	169.99	10053
USAB0001	USABlueBook	04/20/2021	Regular	0.00	1,794.69	10054
	**Void**	04/20/2021	Regular	0.00	0.00	10055
VITU0001	Vituity - Urgent Care Services	04/20/2021	Regular	0.00	50.00	10056
WECK0001	Weck Laboratories, Inc.	04/20/2021	Regular	0.00	443.20	10057
ARC0001	ARC	04/26/2021	Regular	0.00	690.01	10058
AT&T0001	AT&T	04/26/2021	Regular	0.00	48.78	10059
ATKI0001	Atkinson, Andelson, Loya, Ruud & Romo	04/26/2021	Regular	0.00	14,481.00	10060
COUN0001	County of Orange	04/26/2021	Regular	0.00	63.00	10061
DIRE0001	DirectTV LLC	04/26/2021	Regular	0.00	99.99	10062
DUTH0001	Duthie Electric Service Corporation	04/26/2021	Regular	0.00	4,764.96	10063
FEDE0001	FedEx	04/26/2021	Regular	0.00	38.16	10064
GRAI0001	Grainger	04/26/2021	Regular	0.00	3,159.54	10065

Check Report

Date Range: 04/14/2021 - 05/12/2021

Vendor Number	Vendor Name	Payment Date	Payment Type	Discount Amount	Payment Amount	Number
HYDR0002	Hydrotech Electric	04/26/2021	Regular	0.00	18,728.13	10066
INDU0002	Industrial Metal Supply Company	04/26/2021	Regular	0.00	260.44	10067
IRVI0001	Irvine Ranch Water District	04/26/2021	Regular	0.00	69,441.74	10068
JLRA0001	J.L. Ray Company, Inc.	04/26/2021	Regular	0.00	2,166.05	10069
JRTR0001	JRT ROOFING AND WATERPROOFING	04/26/2021	Regular	0.00	26,300.00	10070
OCSU0001	OC Superior Cleaning Services	04/26/2021	Regular	0.00	1,225.00	10071
OCWA0001	OC Waste & Recycling	04/26/2021	Regular	0.00	2,963.83	10072
OLIN0001	Olin Chemicals	04/26/2021	Regular	0.00	1,310.99	10073
OSCA0001	Oscar Ulloa	04/26/2021	Regular	0.00	290.00	10074
ROBE0001	Robertson's Ready Mix LTD	04/26/2021	Regular	0.00	613.10	10075
S&JS0001	S & J Supply Company	04/26/2021	Regular	0.00	1,424.73	10076
TEKD0001	Tekdraulics	04/26/2021	Regular	0.00	3,484.61	10077
TRUC0001	TrucParCo	04/26/2021	Regular	0.00	91.57	10078
VAUG0001	Vaughan's Industrial Repair Co., Inc.	04/26/2021	Regular	0.00	7,680.13	10079
TRUE0001	ALS - Truesdail Laboratories	05/07/2021	Regular	0.00	1,873.00	10081
ARC0001	ARC	05/07/2021	Regular	0.00	1,120.29	10082
BUTI0001	Butier Engineering, Inc.	05/07/2021	Regular	0.00	8,150.00	10083
CHEM0001	Chemtrade Chemicals US LLC	05/07/2021	Regular	0.00	4,558.30	10084
DEPT0005	Department of Water Resources	05/07/2021	Regular	0.00	38,097.00	10085
DOVE0002	Dove Canyon Masters Association	05/07/2021	Regular	0.00	678.00	10086
FERR0002	Ferreira Construction Company	05/07/2021	Regular	0.00	24,221.65	10087
HARR0001	Harrington Industrial Plastics	05/07/2021	Regular	0.00	207.29	10088
JIGC0001	JIG Consultants	05/07/2021	Regular	0.00	3,680.00	10089
MKN0001	Michael K. Nunley & Associates	05/07/2021	Regular	0.00	4,491.57	10090
OLIN0001	Olin Chemicals	05/07/2021	Regular	0.00	4,240.32	10091
ORAN0004	Orange County Pumping, Inc.	05/07/2021	Regular	0.00	2,485.00	10092
O'RE0001	O'Reilly Automotive, Inc.	05/07/2021	Regular	0.00	91.91	10093
PROJ0001	Project Partners, Inc.	05/07/2021	Regular	0.00	4,420.00	10094
S&JS0001	S & J Supply Company	05/07/2021	Regular	0.00	292.39	10095
SIER0001	Sierra Springs	05/07/2021	Regular	0.00	90.75	10096
USAB0001	USABlueBook	05/07/2021	Regular	0.00	390.77	10097
WECK0001	Weck Laboratories, Inc.	05/07/2021	Regular	0.00	110.80	10098
PREM0001	Premier Mail Marketing	05/10/2021	Regular	0.00	923.28	10099
BAVC0001	BAVCO Backflow Apparatus & Valve Co.	05/11/2021	Regular	0.00	26.28	10100
COMO0001	Comoso	05/11/2021	Regular	0.00	2,486.89	10101
DUNN0001	Dunn-Edwards Corporation	05/11/2021	Regular	0.00	150.35	10102
DUTH0001	Duthie Electric Service Corporation	05/11/2021	Regular	0.00	5,275.00	10103
EAGL0001	Eagle Communications	05/11/2021	Regular	0.00	1,086.48	10104
FERR0002	Ferreira Construction Company	05/11/2021	Regular	0.00	467,746.50	10105
HYDR0002	Hydrotech Electric	05/11/2021	Regular	0.00	13,927.53	10106
IRVI0001	Irvine Ranch Water District	05/11/2021	Regular	0.00	18,484.71	10107
JRTR0001	JRT ROOFING AND WATERPROOFING	05/11/2021	Regular	0.00	32,390.00	10108
MATE0002	Material Specialties Corp.	05/11/2021	Regular	0.00	2,071.04	10109
MCFA0001	McFadden-Dale Industrial Hardware	05/11/2021	Regular	0.00	398.04	10110
MKN0001	Michael K. Nunley & Associates	05/11/2021	Regular	0.00	2,522.98	10111
NAPA0001	Napa Auto Parts	05/11/2021	Regular	0.00	938.46	10112
OLIN0001	Olin Chemicals	05/11/2021	Regular	0.00	2,133.90	10113
ORAN0004	Orange County Pumping, Inc.	05/11/2021	Regular	0.00	1,065.00	10114
QUIN0001	Quinn Company	05/11/2021	Regular	0.00	1,461.08	10115
SANT0003	Santa Margarita Water District	05/11/2021	Regular	0.00	660.00	10116
SHEL0002	Shelton Fire Protection Co., Inc.	05/11/2021	Regular	0.00	3,010.00	10117
Stad0001	Stadia Realty, Inc	05/11/2021	Regular	0.00	6,400.00	10118
TEKD0001	Tekdraulics	05/11/2021	Regular	0.00	1,379.20	10119
TOUC0001	Touch Tel Mobile	05/11/2021	Regular	0.00	625.00	10120
TRUC0001	TrucParCo	05/11/2021	Regular	0.00	817.52	10121
UNDE0001	Underground Service Alert/SC	05/11/2021	Regular	0.00	128.74	10122
UNIT0004	United Pumping Service, Inc.	05/11/2021	Regular	0.00	6,631.35	10123
USAE0001	USA Express Tire & Service	05/11/2021	Regular	0.00	127.00	10124
USAB0001	USABlueBook	05/11/2021	Regular	0.00	180.98	10125
VITU0001	Vituity - Urgent Care Services	05/11/2021	Regular	0.00	588.00	10126
West0006	West Marine Products Inc.	05/11/2021	Regular	0.00	158.37	10127

Check Report

Date Range: 04/14/2021 - 05/12/2021

Vendor Number	Vendor Name	Payment Date	Payment Type	Discount Amount	Payment Amount	Number
ADP0001	ADP	04/14/2021	Bank Draft	0.00	75.00	DFT0002022
SHRE0001	Shred-it USA LLC	04/14/2021	Bank Draft	0.00	150.00	DFT0002023
SOUT0002	Southern California Edison	04/14/2021	Bank Draft	0.00	30.97	DFT0002024
COXC0001	Cox Communications	04/15/2021	Bank Draft	0.00	96.45	DFT0002025
CALP0001	CalPERS	04/16/2021	Bank Draft	0.00	8,055.68	DFT0002026
CALP0001	CalPERS	04/16/2021	Bank Draft	0.00	14,226.35	DFT0002027
CALP0001	CalPERS	04/16/2021	Bank Draft	0.00	4,403.97	DFT0002028
UMPQ0001	Umpqua Bank	04/16/2021	Bank Draft	0.00	13,198.70	DFT0002029
ADP0001	ADP	04/19/2021	Bank Draft	0.00	-100,993.75	DFT0002030
ADP0001	ADP	04/19/2021	Bank Draft	0.00	100,993.75	DFT0002030
COXC0001	Cox Communications	04/19/2021	Bank Draft	0.00	689.96	DFT0002031
TOLL0001	The Toll Roads	04/19/2021	Bank Draft	0.00	140.00	DFT0002032
HOME0001	Home Depot	04/20/2021	Bank Draft	0.00	419.38	DFT0002033
LOWE0001	Lowe's	04/20/2021	Bank Draft	0.00	216.06	DFT0002034
ADP0001	ADP	04/20/2021	Bank Draft	0.00	66.38	DFT0002035
ADP0001	ADP	04/22/2021	Bank Draft	0.00	61.50	DFT0002036
ADP0001	ADP	04/30/2021	Bank Draft	0.00	120.00	DFT0002037
TOLL0001	The Toll Roads	04/30/2021	Bank Draft	0.00	140.00	DFT0002038
ADP0001	ADP	04/19/2021	Bank Draft	0.00	100,993.89	DFT0002042
CINT0001	Cintas	05/03/2021	Bank Draft	0.00	149.12	DFT0002043
CINT0001	Cintas	05/03/2021	Bank Draft	0.00	654.81	DFT0002044
CINT0001	Cintas	05/03/2021	Bank Draft	0.00	315.00	DFT0002045
CALP0001	CalPERS	05/04/2021	Bank Draft	0.00	8,055.68	DFT0002046
CALP0001	CalPERS	05/04/2021	Bank Draft	0.00	14,226.35	DFT0002047
CALP0001	CalPERS	05/04/2021	Bank Draft	0.00	4,087.21	DFT0002048
GUAR0001	Guardian	05/03/2021	Bank Draft	0.00	4,470.72	DFT0002049
EPX0001	EPX	05/03/2021	Bank Draft	0.00	3,474.04	DFT0002050
CALP0001	CalPERS	05/03/2021	Bank Draft	0.00	5,266.36	DFT0002051
CALP0001	CalPERS	05/03/2021	Bank Draft	0.00	44,256.70	DFT0002052
VSP0001	VSP	05/03/2021	Bank Draft	0.00	906.08	DFT0002053
ADP0001	ADP	05/04/2021	Bank Draft	0.00	97,076.20	DFT0002054
SANT0003	Santa Margarita Water District	05/03/2021	Bank Draft	0.00	1,400.45	DFT0002055
SANT0003	Santa Margarita Water District	05/03/2021	Bank Draft	0.00	-1,400.45	DFT0002055
VERI0001	Verizon Wireless	05/06/2021	Bank Draft	0.00	1,095.23	DFT0002056
SANT0003	Santa Margarita Water District	05/03/2021	Bank Draft	0.00	1,202.20	DFT0002058
LOWE0001	Lowe's	05/07/2021	Bank Draft	0.00	108.39	DFT0002059
HOME0001	Home Depot	05/07/2021	Bank Draft	0.00	823.64	DFT0002060
COXC0001	Cox Communications	05/10/2021	Bank Draft	0.00	2,381.01	DFT0002061
ADP0001	ADP	05/10/2021	Bank Draft	0.00	1,882.61	DFT0002062
TOLL0001	The Toll Roads	05/10/2021	Bank Draft	0.00	140.00	DFT0002063
SOUT0001	South Coast AQMD	05/11/2021	Bank Draft	0.00	137.63	DFT0002064
SOUT0001	South Coast AQMD	05/11/2021	Bank Draft	0.00	137.63	DFT0002065
EXXO0001	Exxon/Mobil	05/11/2021	Bank Draft	0.00	3,532.10	DFT0002066
SHEL0001	Shell Fleet Plus	05/11/2021	Bank Draft	0.00	1,293.68	DFT0002067
SHRE0001	Shred-it USA LLC	05/11/2021	Bank Draft	0.00	108.00	DFT0002068
UMPQ0001	Umpqua Bank	05/11/2021	Bank Draft	0.00	11,727.93	DFT0002069
HOME0001	Home Depot	05/11/2021	Bank Draft	0.00	816.97	DFT0002070
COXC0001	Cox Communications	05/11/2021	Bank Draft	0.00	1,723.84	DFT0002071
SOUT0001	South Coast AQMD	05/12/2021	Bank Draft	0.00	137.63	DFT0002072
SOUT0001	South Coast AQMD	05/12/2021	Bank Draft	0.00	137.63	DFT0002073
SOUT0001	South Coast AQMD	05/12/2021	Bank Draft	0.00	137.63	DFT0002074
SOUT0001	South Coast AQMD	05/12/2021	Bank Draft	0.00	137.63	DFT0002075
SOUT0001	South Coast AQMD	05/12/2021	Bank Draft	0.00	137.63	DFT0002076
SOUT0001	South Coast AQMD	05/12/2021	Bank Draft	0.00	137.63	DFT0002077

Check Report

Date Range: 04/14/2021 - 05/12/2021

<b>Vendor Number</b>	<b>Vendor Name</b>	<b>Payment Date</b>	<b>Payment Type</b>	<b>Discount Amount</b>	<b>Payment Amount</b>	<b>Number</b>
XERO0001	Xerox Corporation	05/12/2021	Bank Draft	0.00	205.24	DFT0002078

Bank Code APBNK Summary

Payment Type	Payable	Payment	Discount	Payment
	Count	Count		
Regular Checks	186	103	0.00	1,009,554.95
Manual Checks	0	0	0.00	0.00
Voided Checks	0	2	0.00	-394.00
Bank Drafts	212	55	0.00	354,164.44
EFT's	15	10	0.00	108,080.04
	<b>413</b>	<b>170</b>	<b>0.00</b>	<b>1,471,405.43</b>

### All Bank Codes Check Summary

Payment Type	Payable Count	Payment Count	Discount	Payment
Regular Checks	186	103	0.00	1,009,554.95
Manual Checks	0	0	0.00	0.00
Voided Checks	0	2	0.00	-394.00
Bank Drafts	212	55	0.00	354,164.44
EFT's	15	10	0.00	108,080.04
	<b>413</b>	<b>170</b>	<b>0.00</b>	<b>1,471,405.43</b>

### Fund Summary

Fund	Name	Period	Amount
99	Pooled Cash	4/2021	505,066.80
99	Pooled Cash	5/2021	966,338.63
			<b>1,471,405.43</b>



Trabuco Canyon Water District, CA

# Refund Check Register

## Refund Check Detail

UBPKT05670 - Refund customer payment error

Account	Name	Date	Check #	Amount	Code	Receipt	Amount	Type
100-1242-001	BARTLETT, ROBERT	4/28/2021	10080	11,356.29			11356.29	Deposit
<b>Total Refunded Amount:</b>				11,356.29				

## Revenue Code Summary

Revenue Code	Amount
996 - UNAPPLIED CREDITS	11356.29
<b>Revenue Total:</b>	11356.29

## General Ledger Distribution

Posting Date: 04/28/2021

Fund:	Account Number	Account Name	Posting Amount	IFT
10 - Water Fund	10-000-1010	Claim on Cash	-11,356.29	Yes
	10-000-2501	Customer Credit	11,356.29	
<b>10 Total:</b>			0.00	
99 - Pooled Cash	99-000-1004	Bank of the West Checking (Pooled Cash)	-11,356.29	
	99-000-2120	Due to Other Fund	11,356.29	Yes
<b>99 Total:</b>			0.00	
<b>Distribution Total:</b>			0.00	

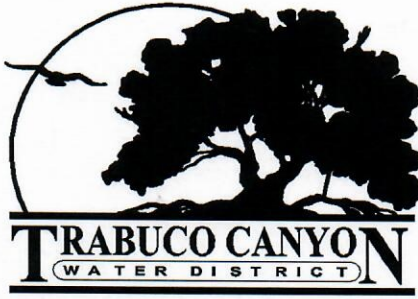

Warrant Registry  
Trabuco Canyon Water District  
County of Orange  
State of California

GENERAL FUND PAYROLL WARRANT REGISTER

For the Month of: May 2021

\$ 205,653.91

I hereby certify that the claims or demands covered by the above listed warrants have been audited as to accuracy and the availability of funds for payment thereof; and that the said claims or demands are accurate and that the funds are available.

This is to certify that claims or demands covered by the above listed warrants have been audited by the Finance/Audit Committee of the Trabuco Canyon Water District and that all of the said warrants are approved for payment.

[Signature] 6/9/21  
General Manager / Assistant General Manager

By [Signature] Date 6/9/21

By [Signature] Date 6/9/21



# Statistical Summary Detail

## TRABUCO CANYON WATER

Region Name : GKN  
Company Code : ADP RESOURCE

Batch : 1544  
Quarter Number : 2  
Service Center : 580

Period Ending : 05/15/2021  
Pay Date : 05/20/2021  
Current Date : 05/18/2021

Week 20  
Page 2

Net Pay	Checks	1,862.37	
	Direct Deposits	61,523.52	
	Subtotal Net Pay	63,385.89	

Adjustments		.00	
Total Net Pay Liability (Net Cash)		63,385.89	

Taxes

You are responsible for Amount debited  
Depositing these amounts from your account

Federal	Agency	Rate	EE withheld	ER contrib.	EE withheld	ER contrib.
	Federal Income Tax		10,579.68			
	Earned Income Credit Advances					
	Social Security		6,067.55		6,067.55	

	Medicare	1,419.01	1,419.02
	Medicare Surtax		
	Federal Unemployment Tax		

Subtotal Federal	18,066.24	7,486.57	25,552.81
FMLA-PSL Payments Credit			

FMLA-PSL ER FICA Credit			
FMLA-PSL Health Care Premium Credit			
Employee Retention Qualified Payments Cre			

Employee Retention Qualified Health Care			
Cobra Premium Assistance Payments			

Total Federal	18,066.24	7,486.57	25,552.81
---------------	-----------	----------	-----------

CA State Income Tax	4,812.14		
CA State Unemployment Insurance-ER 0000	19.42		
CA State Disability Insurance-EE	1,171.88		

Subtotal CA	5,984.02	19.42	6,003.44
Total Taxes	.00	.00	7,505.99
			31,556.25

Amount ADP Debited From AccountXXXX6939	Tran/ABA XXXXXXXXXX	31,556.25	Excludes Taxes That Are Your Responsibility
-----------------------------------------	---------------------	-----------	---------------------------------------------

Other	ADP Direct Deposit	61,523.52	25 Employee Transactions
-------	--------------------	-----------	--------------------------

Transfers	ADP Check	1,862.37	
	Amount ADP Debited From AccountXXXX6939	Tran/ABA XXXXXXXXXX	63,385.89

Total Amount ADP Debited From Your Accounts	94,942.14
---------------------------------------------	-----------



# Statistical Summary Detail

**TRABUCO CANYON WATER**  
Region Name : **GKN**  
Company Code : **ADP RESOURCE**

Batch : **2689**  
Quarter Number : **2**  
Service Center : **580**

Period Ending : **05/31/2021**  
Pay Date : **06/04/2021**  
Current Date : **06/01/2021**

Week **22**  
Page **2**

Net Pay	Checks	2,569.60	
	Direct Deposits	70,342.61	
	Subtotal Net Pay		72,912.21
	Adjustments	.00	
	Total Net Pay Liability (Net Cash)		72,912.21

Taxes

You are responsible for Amount debited  
 Depositing these amounts from your account

Federal	Agency	Rate	EE withheld	ER contrib.	ER contrib.
	Federal Income Tax		13,648.91		
	Earned Income Credit Advances		6,984.44	6,984.44	
	Social Security		1,633.46	1,633.46	
	Medicare		22,266.81	8,617.90	30,884.71
	Medicare Surtax				
	Federal Unemployment Tax				

Subtotal Federal	FMLA-PSL Payments Credit	30,884.71
FMLA-PSL ER FICA Credit		
FMLA-PSL Health Care Premium Credit		
Employee Retention Qualified Payments Cre		
Employee Retention Qualified Health Care		
Cobra Premium Assistance Payments		
Total Federal		8,617.90 30,884.71

State	CA State Income Tax	5,606.86
	CA State Unemployment Insurance-ER 0000	33.75
	CA State Disability Insurance-EE	1,274.24
	Subtotal CA	6,881.10 33.75 6,914.85

Total Taxes	.00 .00 29,147.91 8,651.65 37,799.56	
Amount ADP Debited From AccountXXXX6939	Tran/ABA XXXXXXXXXX	37,799.56

Other

ADP Direct Deposit 70,342.61

Transfers	ADP Check	2,569.60	
	Amount ADP Debited From AccountXXXX6939	Tran/ABA XXXXXXXXXX	72,912.21

Total Amount ADP Debited From Your Accounts 110,711.77

37,799.56 Excludes Taxes That Are Your Responsibility

29 Employee Transactions

**TRABUCO CANYON WATER DISTRICT  
REGULAR BOARD MEETING | JUNE 16, 2021**

**CONSENT CALENDAR**

**ITEM 3: ENGINEERING/OPERATIONAL COMMITTEE MEETING**

---

**RECOMMENDED ACTION:**

*Receive and file the following Engineering/Operational Committee Meeting Recap(s):*

1. *May 5, 2021*

**CONTACTS (staff responsible): PALUDI/PEREA/SANGI**



## TRABUCO CANYON WATER DISTRICT ENGINEERING/OPERATIONAL COMMITTEE MEETING RECAP | MAY 5, 2021

---

### **DIRECTORS PRESENT**

Ed Mandich, Committee Chair  
Stephen Dopudja, Committee Member

### **STAFF PRESENT**

Fernando Paludi, General Manager  
Michael Perea, Assistant General Manager  
Lorrie Lausten, District Engineer  
Karen Warner, Principal Accountant  
Gary Kessler, Water Department Superintendent  
Jason Stroud, Maintenance Superintendent  
Lisa Marie Sangi, Executive Assistant

### **PUBLIC PRESENT VIA CONFERNECE CALL**

None

### **CALL MEETING TO ORDER**

Director Mandich called the May 5, 2021 Engineering/Operational Committee Meeting to order at 7:05 AM. Public access to the meeting was made available by video broadcast.

### **VISITOR PARTICIPATION**

No comments were received.

### **ORAL COMMUNICATION**

No comments were received.

### **COMMITTEE MEMBER COMMENTS**

No comments were received.

### **REPORT FROM THE GENERAL MANAGER**

No comments were received.

### **ITEM 1: ENGINEERING/OPERATIONAL COMMITTEE MEETING RECAP**

Mr. Paludi presented the Engineering/Operational Committee Meeting Recap for Committee review in accordance with the agenda.

### **RECOMMENDED ACTION**

The Committee recommended that the Engineering/Operational Committee Meeting Recap(s) be forwarded to the Board of Directors for approval (Consent Calendar).

Director Dopudja and Mr. Perea recommended the Special Engineering Committee Recap to be forwarded the Board of Directors for approval (Consent Calendar).

**TRABUCO CANYON WATER DISTRICT  
ENGINEERING/OPERATIONAL COMMITTEE MEETING RECAP | MAY 5, 2021**

**ITEM 2: DISCUSSION AND POSSIBLE ACTION(S) CONCERNING BELL CANYON SEWER LIFT STATION REHABILITATION PROJECT**

---

Ms. Lausten provided a project status to the Committee, and she reported that the project tentative completion date is July 5, 2021. Ms. Lausten added that certain project-related items have been delayed due to schedule delays by Southern California Edison (SCE) outside of District control. Ms. Lausten reported that GMU Geotechnical had completed the onsite vibration monitoring and reported no adverse impacts. Discussion occurred concerning the project timeline for completion. Ms. Lausten reported that two of the three new pumps were damaged in transit, and that District staff is meeting with the pump vendor to discuss a plan to remediate the damages.

**RECOMMENDED ACTION:**

The Committee received the status update.

**ITEM 3: OTHER ENGINEERING AND OPERATIONS PROJECTS**

---

**1. 2020 Urban Water Management Plan (UWMP) and Water Shortage Contingency Plan (WSCP) Update**

Mr. Paludi introduced this matter for Committee consideration, and he reported that a Special Board Meeting has been scheduled to review the 2020 Urban Water Management Plan (UWMP) Update and the Water Shortage Contingency Plan (WSCP) requirement. Mr. Paludi added that District General Legal Counsel has been involved in the preparation of the WSCP and will attend the Special Board Meeting. Ms. Lausten provided a brief review of UWMP update requirements in comparison to the 2015 UWMP, and she reviewed the public notification and adoption schedule.

**2. Saddle Crest Development**

Ms. Lausten provided an update on this matter to the Committee, she reported that developer has advised the District that a portion of the parcels have been sold to another developer for construction. Mr. Paludi provided an update on his recent discussion with the developer. Discussion occurred concerning certain terms of the Settlement Agreement and future development needs

**3. Other Projects**

Ms. Lausten provided a brief project update on the District SCADA upgrade project for following fiscal year.

**RECOMMENDED ACTION**

The Committee received the status update. There was no action taken.

**ITEM 4: WATER SYSTEM UPDATES**

---

Mr. Kessler reviewed the projects and repairs for April 2021, and he provided the additional highlights:

1. Water Operations staff assisted Ferreira Construction with the completion of the 16- inch leak repair on the El Toro Bike Trail, which was caused by the County of Orange personnel.
2. Water Operations staff assisted Ferreira Construction with the install of the 16-inch isolation valve, main distribution line on the El Toro Bike Trail.
3. Water Operations staff converted the three (3) Dry Barrel Hydrants to Wet Barrel Hydrants in the Robinson Ranch Community, Hamilton Trail and O'Neil Park Shopping Center in the Canyon Community.
4. Water Operations staff replaced two Air Vacs at Regency Park in Lake Forest, and the Upper Falcon Zone in the Canyon Community.
5. Water Operations staff repaired a 6-inch hydrant valve on Morningside Drive in the Trabuco Highlands Community.

**TRABUCO CANYON WATER DISTRICT  
ENGINEERING/OPERATIONAL COMMITTEE MEETING RECAP | MAY 5, 2021**

6. Water Operations staff conducted seven (7) fire flow test for the Developer on Hamilton Trail in the Canyon Community.

Mr. Kessler reviewed the Monthly Water System Operations Summary with the Committee. Discussion occurred concerning dry barrel hydrant replacement in the District's service area.

**RECOMMENDED ACTION**

The Committee received the status update. There was no action taken.

**ITEM 5: WASTEWATER SYSTEM UPDATES**

---

Mr. Perea reviewed the projects and repairs for April 2021, and he reported that Wastewater Operations staff had completed the following tasks:

1. Performed routine maintenance on the Robinson Ranch Wastewater Treatment Plant (WWTP) Filtration System by replenishing the anthracite coal media and cleaned the filter backwash tank.
2. Worked with Maintenance Department staff to clean the WWTP Chlorine Contact Chamber.
3. Prepared the spare filter tank at the WWTP for removal and disposal.
4. Worked with Maintenance Department staff to add a new Equalization Basin sump pump panel.
5. Hosted a tour of the WWTP for a local Robinson Ranch Girl Scout Troop on Friday, April 30<sup>th</sup>.

Mr. Perea reviewed the Monthly Wastewater System Operations Summary with the Committee, and he reported that non-domestic water demand has increased by approximately five percent from the same month in the prior year.

**RECOMMENDED ACTION**

The Committee received the status update. There was no action taken.

**ITEM: 6 MAINTENANCE DEPARTMENT UPDATES**

---

Mr. Stroud reviewed the projects and repairs for April 2021, and he provided the additional highlights:

1. Maintenance Department staff began assembly for the newly purchased vehicles for District Operations staff.
2. Maintenance Department staff installed a new pump/motor for the Tick Creek Dry Season Recovery Booster Station.
3. Maintenance Department staff continued the electrical upgrades and repairs at the Robinson Ranch Wastewater Treatment Plant.
4. Maintenance Department staff worked with Sanitation Operations to re-pack multimedia filters at the Robinson Ranch Wastewater Treatment Plant.
5. Maintenance Department staff has completed the EMASS program with TESCO Controls.

**RECOMMENDED ACTION**

The Committee received the status update. There was no action taken.

**TRABUCO CANYON WATER DISTRICT  
ENGINEERING/OPERATIONAL COMMITTEE MEETING RECAP | MAY 5, 2021**

**ITEM 7: OTHER MATTERS/REPORTS**

---

Discussion occurred concerning the potential impacts of Senate Bill (SB) 9.

**RECOMMENDED ACTION**

There was no action taken.

**ADJOURNMENT**

Director Mandich adjourned the May 5, 2021 Engineering/Operational Committee Meeting at 7:25AM.

DRAFT

**TRABUCO CANYON WATER DISTRICT  
REGULAR BOARD MEETING | JUNE 16, 2021**

**CONSENT CALENDAR**

**ITEM 4: EXECUTIVE COMMITTEE MEETING**

---

**RECOMMENDED ACTION:**

*Receive and file the following Executive Committee Meeting Recap(s):*

- 1. March 23, 2021*

**CONTACTS (staff responsible): PALUDI/PEREA**



## TRABUCO CANYON WATER DISTRICT EXECUTIVE COMMITTEE MEETING RECAP | MARCH 23, 2021

---

### **DIRECTORS PRESENT**

Vice President Stephen Dopudja, Committee Chair  
President Don Chadd, Committee Member

### **STAFF PRESENT**

Fernando Paludi, General Manager  
Michael Perea, Assistant General Manager

### **CONSULTANTS PRESENT VIA TELECONFERENCE**

Rob Anslow, District General Legal Counsel (Atkinson, Andelson, Loya, Ruud, & Romo)

### **PUBLIC PRESENT**

There were no members of the public present

### **CALL MEETING TO ORDER**

Vice President Dopudja called the March 23, 2021 Executive Committee Meeting to order at 5:00 PM.

### **VISITOR PARTICIPATION**

No visitor participation was received.

### **ORAL COMMUNICATION**

No oral communication was received.

### **COMMITTEE MEMBER COMMENTS**

Vice President Dopudja had no comments.

President Chadd had no comments.

### **REPORT FROM THE INTERIM GENERAL MANAGER**

Mr. Paludi had no comments.

### **BOARD AGENDA MATTERS**

#### **ITEM 1: EXECUTIVE COMMITTEE MEETING RECAP**

---

Mr. Paludi presented the Executive Committee Meeting Recap for Committee review in accordance with the agenda.

#### **Recommended Action:**

The Committee recommended that the meeting recap be forwarded to the Board of Directors for approval (Consent Calendar).

**TRABUCO CANYON WATER DISTRICT  
EXECUTIVE COMMITTEE MEETING RECAP | MARCH 23, 2021**

**DISCUSSION MATTERS**

**ITEM 2: DISCUSSION CONCERNING DOMESTIC WATER STORAGE CAPACITY**

---

There was no discussion on this matter.

**Recommended Action:**

There was no action taken by the Committee.

**CLOSED SESSION**

*The Committee entered Closed Session at 5:03 p.m.*

**CLOSED SESSION NO. 1: CONFERENCE WITH LEGAL COUNSEL - ANTICIPATED LITIGATION**

---

The Committee met in Closed Session regarding significant exposure to legal proceedings and/or litigation pursuant to Government Code Sections 54956.9(d)(2) and 54954.5(c) - Number of Potential Cases: 1

The District's General Manager, Assistant General Manager, and General Legal Counsel participated in the closed session.

*The Board of Directors reconvened in Open Session at 5:27 p.m.*

**ITEM 3: REPORT OF ACTION(S) TAKEN IN CLOSED SESSION**

---

**Action:** No announcement concerning action(s) taken in closed session was made.

**OTHER MATTERS**

**ITEM 4: OTHER MATTERS OR COMMENTS FROM INTERIM GENERAL MANAGER AND/OR STAFF**

---

There was no discussion on this matter.

**Recommended Action:**

There was no action taken by the Committee.

**ADJOURNMENT**

Vice President Dopudja adjourned the March 23, 2021 Executive Committee Meeting at 5:29 PM.

**TRABUCO CANYON WATER DISTRICT  
REGULAR BOARD MEETING | JUNE 16, 2021**

**ACTION CALENDAR**

**ADMINISTRATIVE MATTERS**

**ITEM 5: RATIFICATION OF DIRECTORS' FEES AND EXPENSES, AND TENTATIVE FUTURE MEETINGS/  
ATTENDANCE**

---

***FEES AND EXPENSES***

Consistent with Board policy, Directors are reimbursed for expenses incurred while serving in their capacity as Directors. Additionally, Directors earn a per diem stipend for attendance at meetings or functions in a Director capacity. The attached spreadsheet provides a recap of the meetings, seminars, conferences attended by Directors along with expenses recorded to date.

***TENTATIVE FUTURE MEETINGS***

The attached spreadsheet provides a schedule of the tentative future meetings and attendance items.

**FUNDING SOURCE:**

General Fund

**FISCAL IMPACT**

FY 2020/2021 Budgeted Board Expenses: \$39,600

**ENVIRONMENTAL COMPLIANCE:**

Not applicable

**COMMITTEE STATUS:**

This matter was reviewed with the Finance/Audit Committee.

**RECOMMENDED ACTIONS:**

*Approve the tentative future meetings/attendance items and ratify the Directors' expenses and fees from the following period(s):*

1. *May 2021*

**EXHIBIT(S):**

1. Directors Fees and Expenses Monthly Report for May 2021
2. Directors Future/Tentative Meeting/Attendance Schedule for Calendar Year 2021

**CONTACTS (staff responsible): PALUDI/PEREA/SANGI**

**TRABUCO CANYON WATER DISTRICT  
DIRECTORS' FEES AND EXPENSES MONTHLY REPORT | MAY 2021**

<b>MEETING DESCRIPTION</b>	<b>ACOSTA</b>	<b>CHADD</b>	<b>DOPUDJA</b>	<b>MANDICH</b>	<b>SAFRANSKI</b>
<b>DISTRICT MEETINGS</b>					
Special Board Meeting	05/03/21	05/03/21	05/03/21	05/03/21	05/03/21
Engineering/Operational Committee Meeting			05/05/21	05/05/21	
Finance/Audit Committee Meeting		05/12/21		05/12/21	
Bell Canyon Lift Station Site Visit				05/13/21	05/13/21
District Property Ad Hoc Committee Meeting			05/17/21		05/17/21
Individual Meeting with General Manager	05/11/21	05/18/21		05/17/21	
Regular Board Meeting		05/19/21	05/19/21	05/19/21	05/19/21
Special Board Meeting - Budget Workshop	05/24/21	05/24/21	05/24/21	05/24/21	05/24/21
<b>REPRESENTATIVE MEETINGS</b>					
City of Rancho Santa Margarita Council Meeting	05/12/21				
City of Rancho Santa Margarita Council Meeting					05/26/21
City of Rancho Santa Margarita City Planning Commission Meeting	05/05/21				
Independent Special Districts of Orange County Meeting					
South Orange County Water Agencies Group Meeting					05/27/21
South Orange County Wastewater Authority (SOCWA) Regular Board Meeting			05/06/21		
South Orange County Integrated Regional Watershed Management Executive Committee				05/06/21	
Water Advisory Committee of Orange County Meeting (WACO)	05/07/21				
<b>NUMBER OF MEETINGS ATTENDED</b>	<b>6</b>	<b>5</b>	<b>6</b>	<b>8</b>	<b>7</b>
<b>FEES (\$125 per each meeting*)</b>	<b>\$750.00</b>	<b>\$625.00</b>	<b>\$750.00</b>	<b>\$1,000.00</b>	<b>\$875.00</b>
<b>DIRECT REIMBURSABLE EXPENSES</b>					
<b>DIRECT REIMBURSABLE EXPENSES TOTALS</b>	<b>\$0.00</b>	<b>\$0.00</b>	<b>\$0.00</b>	<b>\$0.00</b>	<b>\$0.00</b>
<b>INDIRECT REIMBURSABLE EXPENSES</b>					
<b>INDIRECT REIMBURSABLE EXPENSES TOTALS</b>					
<b>TOTAL</b>	<b>\$750.00</b>	<b>\$625.00</b>	<b>\$750.00</b>	<b>\$1,000.00</b>	<b>\$875.00</b>
<i>* Maximum per diem per day is one; maximum per diems per month is 10</i>					

**DIRECTOR SIGNATURE**

**TRABUCO CANYON WATER DISTRICT | 2021 PUBLIC MEETING AND CONFERENCE CALENDAR**

2021													
LINE ITEM	MEETING DESCRIPTION	JAN	FEB	MAR	APR	MAY	JUN	JUL	AUG	SEP	OCT	NOV	DEC
<b>DISTRICT PUBLIC MEETINGS</b>													
1	Executive Committee Meeting	TBD			TBD			TBD			TBD		
2	Engineering/Operational Committee Meeting	01/06/21	02/03/21	03/03/21	04/07/21	05/05/21	06/02/21	07/07/21	08/04/21	09/01/21	10/06/21	11/03/21	12/01/21
3	Finance/Audit Committee Meeting	01/13/21	02/10/21	03/10/21	04/14/21	05/12/21	06/09/21	07/14/21	08/11/21	09/08/21	10/13/21	11/10/20	12/08/21
4	Regular Board Meeting	01/20/21	02/17/21	03/17/21	04/21/21	05/19/21	06/16/21	07/21/21	08/18/21	09/15/21	10/20/21	11/17/21	12/15/21
5	District Properties Ad Hoc Committee Meeting	-	-	-	-	-	-	-	-	-	-	-	-
<b>PUBLIC MEETINGS</b>													
6	City of RSM City Council Meeting - Meeting No. 1	01/13/21	02/10/21	03/10/21	04/14/21	05/12/21	06/09/21	07/14/21	08/11/21	09/08/21	10/13/21	11/10/21	12/08/21
7	City of RSM City Council Meeting - Meeting No. 2	01/27/21	02/24/21	03/24/21	04/28/21	05/26/21	06/23/21	07/28/21	08/25/21	09/22/21	10/27/21	11/24/21	12/22/21
8	Independent Special Districts of Orange County Meeting	01/05/21	02/02/21	03/02/21	04/06/21	05/04/21	06/01/21	07/06/21	08/03/21	09/07/21	10/05/21	11/02/21	12/07/21
9	Independent Special Districts of Orange County Meeting	01/28/21	-	-	04/29/21	-	-	07/29/21	-	-	10/28/21	-	-
10	Orange County Local Agency Formation Commission (OC LAFCO)	01/13/21	02/10/21	03/10/21	04/14/21	05/12/21	06/09/21	07/14/21	08/11/21	09/08/21	10/13/21	11/10/21	12/08/21
11	Santiago Aqueduct Commission Meeting	-	-	03/18/21	-	-	06/17/21	-	-	09/16/21	-	-	12/16/21
12	South Orange County Integrated Regional Watershed Management Executive Committee	-	-	03/04/21	-	05/06/21	-	-	08/05/21	-	-	11/04/21	-
13	South Orange County Water Agencies Group Meeting*	01/28/21	-	03/25/21	-	05/27/21	-	07/22/21	-	09/23/21	-	11/25/21	-
14	South Orange County Wastewater Authority Regular Board Meeting	01/07/21	02/04/21	03/04/21	04/07/21	05/06/21	06/03/21	07/01/21	08/05/21	09/02/21	10/07/21	11/04/21	12/02/21
15	Water Advisory Committee of Orange County	01/01/21	02/05/21	03/05/21	04/02/21	05/07/21	06/04/21	07/02/21	08/07/21	09/03/21	10/01/21	11/06/21	12/04/21
<b>CONFERENCES</b>													
16	ACWA Spring Conference - Monterey, CA					5/11 - 5/14							
17	ACWA Fall Conference - Pasadena, CA											11/30 12/3	
18	CSDA Annual Conference -Monterey, CA								8/3 - 9/2				
19	CSDA GM Leadership Summit - Olympic Valley, CA						6/27 - 6/29						
20	CSDA SDLA Conference - Lake Tahoe, CA									9/26 - 9/29			

**LEGEND**  
 District Observed Holiday - Reschedule Meeting  
 \*4th Tuesday of the Odd Numbered Month

**TRABUCO CANYON WATER DISTRICT  
REGULAR BOARD MEETING | JUNE 16, 2021**

**ACTION CALENDAR**

**ADMINISTRATIVE MATTERS**

**ITEM 6: PUBLIC HEARING AND ADOPTION OF TRABUCO CANYON WATER DISTRICT'S 2020 URBAN WATER MANAGEMENT PLAN (UWMP) UPDATE, WATER SHORTAGE CONTINGENCY PLAN, AND 2015 UWMP ADDENDUM**

---

The Urban Water Management Plan (WMP) is a long-term planning document required by the State of California to be prepared by water suppliers every five years with the 2020 submittal due July 1, 2021. For this latest update to the UWMP, Trabuco Canyon Water District (District) will involve four separate actions:

1. Adopt the 2020 UWMP by Resolution
2. Adopt an Addendum to the 2015 UWMP by Resolution
3. Adopt a Water Shortage Contingency Plan by Resolution
4. Update the District's Water Conservation Ordinance (this will be adopted separately from the first three actions, in July or August 2021)

The purpose of the Addendum to TCWD's 2015 UWMP is to demonstrate consistency with the Delta Plan Policy WR P1 to "Reduce Reliance on the Delta Through Improved Regional Water Self-Reliance". Adoption of the Addendum is being encouraged by the California Department of Water Resources and Delta Stewardship Council pursuant to Sacramento-San Joaquin Delta Reform Act, the Delta Plan, and Water Code Section 85021, which declares that the State's policy is to "reduce reliance on the Delta in meeting California's future water needs through a statewide strategy of investing in imported regional supplies, conservation, and water use efficiency."

The Water Shortage Contingency Plan (WSCP) has been a required component within the UWMP for decades but pursuant to recently adopted legislation AB 1668 and SB 606, commonly referred to as "Making Water Conservation a California Way of Life", the WSCP is required to be a stand-alone document created separately but that can also be reference in the UWMP.

The purpose of the WSCP document is to serve as a roadmap for suppliers to follow when water shortages occur due to natural disasters such as drought or earthquakes, system failures, or regulatory actions. Unlike the UWMP, the WSCP is a short-term planning tool to be revisited annually to account for changing conditions. Historically, Trabuco Canyon Water District (TCWD) used its Conservation Ordinance as the water shortage planning document. To comply with the new requirements, the District will now adopt the WSCP and revise its Conservation Ordinance to be consistent with, and provide the means to enforce, the actions within the WSCP.

The WSCP applies to potable or domestic water and recycled or non-domestic water as determined by the District in the event of shortage or emergency. Uniform application of the requirements is not required. For example, in the event of a drought impacting domestic water, the District will likely not implement the contingencies on recycled water use. One significant change to note in the WSCP is the District revising the number of water shortage stages from four (4) in the existing ordinance to six (6) in the WSCP. The State has established six (6) stages of water shortage that progressively escalate in ten percent increments (10, 20, 30, 40, 50, and >50% supply shortages). The District's proposed increase to six water shortage states is to align with the State's requirement while establishing regional consistency and messaging with Metropolitan Water District and Municipal Water District of Orange County.

The WSCP also establishes locally appropriate "shortage response actions" for each shortage level, with a corresponding estimate of the extent the action will address the gap between supplies and demands. The District's response actions comply with the State's requirements that mandate water suppliers demonstrate categories of

**TRABUCO CANYON WATER DISTRICT  
REGULAR BOARD MEETING | JUNE 16, 2021**

response actions, along with their estimated savings potential, that either reduce demand, augment supplies, demonstrate operational changes, or invoke additional mandatory prohibitions on specific water uses. The District's actions are summarized in the attached response matrix which provides an overview of the proposed strategic approach on how the District can mitigate a given water supply shortage condition.

Consistent with the adoption notification process, the District published a Notice of Public Hearing in the Orange County Register once a week for two consecutive weeks no less than five days apart on June 1<sup>st</sup> and 8<sup>th</sup> (Exhibit 2).

**FUNDING SOURCE:**

General Fund.

**FISCAL IMPACT:**

None

**ENVIRONMENTAL COMPLIANCE:**

Not applicable.

**COMMITTEE STATUS:**

This matter was reviewed with the Finance/Audit Committee.

**RECOMMENDED ACTION:**

*Recommend the Board of Directors take the following actions:*

- 1. Conduct a Public Hearing to receive public comments related to the approval and adoption of the 2020 Urban Water Management Plan (UWMP) Update, Water Shortage Contingency Plan (WSCP), and 2015 UWMP Addendum*
- 2. Adopt Resolution No. 2021- 1290 - Resolution of the Board of Directors of Trabuco Canyon Water District Adopting An Addendum to the Trabuco Canyon Water District 2015 Urban Water Management Plan to Add Appendix K – Reduced Delta Reliance Reporting (Appendix C of 2020 UWMP) -*
- 3. Adopt Resolution No. 2021-1291 – Resolution of the Board of Directors of the Trabuco Canyon Water District Adopting the Trabuco Canyon Water District Revised Water Shortage Contingency Plan*
- 4. Adopt Resolution No. 2021-1292 – Resolution of the Board of Directors of the Trabuco Canyon Water District Adopting the Trabuco Canyon Water District 2020 Urban Water Management Plan Update*

**EXHIBIT(S):**

1. Summary of Shortage Response Actions
2. Orange County Register Affidavit of Publication
3. DRAFT Resolution No. 2021- 1290 - Resolution of the Board of Directors of Trabuco Canyon Water District Adopting the District's Addendum to the 2015 UWMP to Add Appendix K (Appendix C of 2020 UWMP)
4. DRAFT Resolution No. 2021-1291 – Resolution of the Board of Directors of the Trabuco Canyon Water District Adopting the Trabuco Canyon Water District Revised Water Shortage Contingency Plan
5. DRAFT Resolution No. 2021-1292 – Resolution of the Board of Directors of the Trabuco Canyon Water District Adopting the Trabuco Canyon Water District 2020 Urban Water Management Plan Update

**CONTACTS (staff responsible): PALUDI/PEREA/LAUSTEN**

**TCWD Water Shortage Contingency Plan  
Summary of Shortage Response Actions**

<b>Water Shortage Stage</b>	<b>Shortage Response Actions</b>	<b>Response Action Type</b>	<b>% Gap Reduced</b>
<b>Stage 1:</b> Up to 10% Shortage	Increase public awareness of water supply situation	DR	3%
	Encourage voluntary outdoor water use efficiency	DR	3%
	Promote Rebates for Indoor and Outdoor Water Use Efficiency	DR	2%
	Require customers to fix leaks within 72 hours	MP	1%
	Reinforce permanent conservation measures	MP	1%
<b>Stage 2:</b> Up to 20% Shortage	Expand public awareness of shortage situation and leverage regional outreach and marketing efforts by MWDOC and MET	DR	5%
	Targeted outreach to dedicated irrigation customers using drinking water	DR	2%
	Voluntary limits to landscape watering with drinking water: 3 days per week April through October and 1 day per week November through March; allowances for Fuel Modification Zones (FMZ)	DR	3%
	Require customers to fix leaks within 48 hours	MP	1%
	Targeted Outreach to Commercial Agriculture and Nurseries	DR	1%
	Encourage customers with recreational water features to implement BMPs for pools and spas	DR	1%
	Water at restaurants only upon request	DR	1%
<b>Stage 3:</b> Up to 30% Shortage	Targeted outreach and assistance to high use customers	DR	5%
	Enhanced water conservation activities, marketing, and incentives	DR	2%
	Limit landscape watering with drinking water to 3 days per week April through October and 1 day per week November through March; allowances for FMZs	MP	5%
	Limit commercial nurseries using drinking water for irrigation by 30% monthly based on 5-yr average use	DR	3%
	Requirement for customers to fix leaks within 24 hours	MP	1%
	Limits on use of potable water for construction	OC	1%
	Limit street sweeping to use of recycled water only	OC	1%
	Reduce frequency of line cleaning and flushing	OC	1%
<b>Stage 4:</b> Up to 40% Shortage	Limit landscape watering with drinking water to 2 days per week April through October and 1 day per week November through March; allowances for FMZs	MP	5%
	Limit commercial nurseries using drinking water for irrigation by 40% monthly based on 5-yr average use	DR	2%
	Prohibition on filling and refilling of decorative water features	MP	1%
	No new potable water services except under certain circumstances	OC	2%

## TCWD Water Shortage Contingency Plan Summary of Shortage Response Actions

<b>Stage 5:</b> Up to 50% Shortage	Expand enforcement and outreach to high water users	DR	5%
	Require installation of flow restrictors on high water users that are non-responsive to outreach	DR	1%
	Prohibit all irrigation of turf with drinking water, except for school and HOA-owned sports fields as required to stay alive	MP	2%
	Limit non-turf landscape watering with drinking water to 1 day per week all months; allowances for FMZs	MP	3%
	Limit commercial nurseries using drinking water for irrigation by 50% monthly based on 5-yr average use	MP	2%
	Prohibit filling of all recreational water features, such as pools and spas, that do not follow BMPs	MP	2%
<b>Stage 6:</b> Over 50% Shortage	Conduct emergency public outreach	DR	5%
	Allocate water supply as deemed necessary under an emergency supply condition	DR	As necessary
	Prohibit all landscape watering with drinking water; allowances for FMZs	MP	3%
	Prohibit commercial nurseries from all irrigation using drinking water	MP	5%
	Prohibit all vehicle washing, including commercial car washes	MP	1%
	Other water response shortage actions, as needed	MP	5%

DR = Demand Reduction  
MP = Mandatory Prohibition  
OC = Operational Change

**PROOF OF PUBLICATION**

**AFFIDAVIT OF PUBLICATION**

STATE OF CALIFORNIA, )

) ss.

County of Orange )

I am a citizen of the United States and a resident of the County aforesaid; I am over the age of eighteen years, and not a party to or interested in the above entitled matter. I am the principal clerk of **The Orange County Register**, a newspaper of general circulation, published in the city of Santa Ana, County of Orange, and which news-paper has been adjudged to be a newspaper of general circulation by the Superior Court of the County of Orange, State of California, under the date of November 19, 1905, Case No. A-21046, that the notice, of which the annexed is a true printed copy, has been published in each regular and entire issue of said newspaper and not in any supplement thereof on the following dates, to wit:

June 1, 8, 2021

"I certify (or declare) under the penalty of perjury under the laws of the State of California that the foregoing is true and correct":

Executed at Santa Ana, Orange County, California, on

Date: June 8, 2021



Signature

**The Orange County Register  
2190 S. Towne Centre Pl.  
Anaheim, CA 92806**



**T TRABUCO CANYON WATER DISTRICT  
NOTICE OF PUBLIC HEARING  
2020 URBAN WATER MANAGEMENT PLAN  
UPDATE AND  
WATER SHORTAGE CONTINGENCY PLAN**

NOTICE IS HEREBY GIVEN that the Board of Directors of the Trabuco Canyon Water District (TCWD or District) will hold a public hearing on **Wednesday, June 16, 2021 at 7:00 p.m.**, or as soon thereafter as the Agenda permits, in the District's Administrative Facility located at 32003 Dove Canyon Drive, Trabuco Canyon, CA 92679, to consider the District's proposed 2020 Urban Water Management Plan ("UWMP"), 2020 Water Shortage Contingency Plan ("WSCP"), and Appendix C as an Addendum to its 2015 UWMP in advance of their proposed adoption.

The public hearing is being held in accordance with the Urban Water Management Planning Act (California Water Code Sections 10610 through 10656; herein referred to as the "Act"). The Act requires every urban water supplier providing water for municipal purposes to more than 3,000 customers or supplying more than 3,000 acre-feet of water annually" to prepare, adopt, and file a UWMP with the California Department of Water Resources and review and update its UWMP every five years. The purpose of the public hearing will be to solicit public comment prior to adoption of the proposed updated UWMP and WSCP.

Copies of the proposed 2020 UWMP, 2020 WSCP, and Appendix C as an Addendum to its 2015 UWMP are available for public inspection at the District's Administration Facility, which is located at 32003 Dove Canyon Drive, Trabuco Canyon, CA 92679, during normal business hours of 7:00 a.m. to 4:00 p.m. It will also be available on the District's website at [www.tcwd.ca.gov](http://www.tcwd.ca.gov)

TCWD's public hearing is scheduled for **Wednesday, June 16, 2021 at 7:00 p.m.**, and as a result of the COVID-19 emergency and the Governor's Executive Orders to protect public health by limiting public gatherings and requiring social distancing, at this time, the meeting is scheduled to occur via the following virtual meeting application. Instructions for joining the meeting are as follows:

**COMPUTER AUDIO:** <https://zoom.us/j/91386811652>

**TELEPHONE AUDIO:** 1 (669) 900-6833

**MEETING ID:** 913 8681 1652

For more information, or if you would like assistance in presenting your comments to the Board of Directors at the public hearing, please contact Michael Perea, District Secretary at (949) 858-0277 or via email at [mperea@tcwd.ca.gov](mailto:mperea@tcwd.ca.gov).

Published: Orange County Register

**RESOLUTION NO. 2021-1290**

**RESOLUTION OF THE BOARD OF DIRECTORS  
OF TRABUCO CANYON WATER DISTRICT  
ADOPTING AN ADDENDUM TO THE TRABUCO CANYON WATER DISTRICT  
2015 URBAN WATER MANAGEMENT PLAN  
TO ADD APPENDIX K – REDUCED DELTA RELIANCE REPORTING  
(APPENDIX C OF 2020 UWMP)**

---

**WHEREAS**, the Trabuco Canyon Water District ("District") is a county water district organized and operating pursuant to the provisions of California Water Code ("Water Code") Sections 30000 and following; and

**WHEREAS**, Water Code Sections 10610 through 10656 of the Urban Water Management Planning Act ("Act") require that every urban water supplier providing water for municipal purposes to more than 3,000 customers or supplying more than 3,000 acre feet of water annually to prepare, adopt, and file with the Department of Water Resources("DWR") every five years in the years ending in zero and five;

**WHEREAS**, the District is an urban supplier of water which is subject to the provisions and requirements of the Act; and

**WHEREAS**, the District previously prepared, considered, reviewed and adopted its Urban Water Management Plan ("Plan") and the District's 2015 Urban Water Management Plan Update pursuant to the provisions of the Act; and

**WHEREAS**, the District submitted the Trabuco Canyon Water District 2015 Urban Water Management Plan Update to the DWR as provided for pursuant to the Act;

**WHEREAS**, The Delta Plan was adopted in 2013 by the Delta Stewardship Council;

**WHEREAS**, Delta Plan Policy WR P1 ("WR P1") is one of fourteen regulatory policies included in the Delta Plan;

**WHEREAS**, WR P1 identifies Urban Water Management Plans as the tool to demonstrate consistency with State of California policy to reduce reliance on the Delta for a Supplier (as defined in the Delta Plan) that anticipates receiving water supply benefits from the Delta;

**WHEREAS**, WR P1 states that, commencing in 2015, Suppliers that have: (A) completed an Urban Water Management Plan; (B) implemented the efficiency measures in that Urban Water Management Plan; and (C) shown a measurable reduction in Delta reliance and improvement in regional self-reliance in their Urban Water Management Plan, are contributing to reduced reliance on the Delta consistent with WR P1;

**WHEREAS**, There was no mention of the Delta Plan Policy in the DWR 2015 Urban Water Management Plan Guidebook;

**WHEREAS**, DWR 2020 Urban Water Management Plan Guidebook (Appendix C) recommends that Suppliers prepare and submit the above-referenced information as an appendix to their Urban Water Management Plan; and

**WHEREAS**, the District is amending its 2015 Urban Water Management Plan Update through the addition of Appendix C – Reduced Delta Reliance Reporting (“Amendment”); and

**WHEREAS**, members of the District’s Board of Directors (“Board’) have been provided with a copy of the Amendment; and

**WHEREAS**, the Board has determined that it is appropriate, and in the best interests of the District, to adopt the Amendment at this time.

**NOW, THEREFORE, THE BOARD OF DIRECTORS OF THE TRABUCO CANYON WATER DISTRICT DOES HEREBY RESOLVE, DETERMINE, AND ORDER AS FOLLOWS:**

**Section 1.** The foregoing recitals are true and correct and are incorporated herein by this reference.

**Section 2.** The Board of Directors hereby adopts the Amendment, which is incorporated herein by this reference, and will implement the Amendment in accordance with the terms set forth therein.

**Section 3.** The District Secretary is hereby directed to submit the Amendment to the California Department of Water Resources, the California State Library, and any city or county within which the District provides water supplies, no later than 30 days from the date of adoption of this Resolution, as provided for under California Water Code Section 10644(a)(1).

**Section 4.** The General Manager, District Secretary and other District staff and consultants are authorized and directed to take all other and further actions necessary or desirable to carry out the directives of this Resolution.

**ADOPTED, SIGNED AND APPROVED this 16<sup>th</sup> day of June, 2021.**

**TRABUCO CANYON WATER DISTRICT**

By: \_\_\_\_\_  
President/Vice President

By: \_\_\_\_\_  
District Secretary

STATE OF CALIFORNIA            )  
                                                  ) ss.  
COUNTY OF ORANGE            )

I, Michael Perea, District Secretary of the Trabuco Canyon Water District, do hereby certify that the foregoing resolution was duly adopted by the Board of said District at a regular meeting of such Board held on the 16<sup>th</sup> day of June, 2021 of which meeting all of the members of the Board had due notice and at which a quorum thereof were present and acting throughout and for which notice and an agenda was prepared and posted as required by law and that at said meeting such resolution was adopted by the following vote:

AYES:

NOES:

ABSTAIN:

ABSENT:

\_\_\_\_\_  
District Secretary,  
Trabuco Canyon Water District

DRAFT

STATE OF CALIFORNIA            )  
                                                  ) ss.  
COUNTY OF ORANGE            )

I, Michael Perea, District Secretary of the Trabuco Canyon Water District, do hereby certify that the foregoing is a full, true, and correct copy of Resolution No. 2021-1290 of such Board and that the same has not been amended, rescinded or repealed.

Dated this 16<sup>th</sup> day of June, 2021.

\_\_\_\_\_  
District Secretary,  
Trabuco Canyon Water District

DRAFT

**RESOLUTION NO. 2021-1291**

**RESOLUTION OF THE BOARD OF DIRECTORS  
OF THE TRABUCO CANYON WATER DISTRICT  
ADOPTING THE TRABUCO CANYON WATER DISTRICT  
REVISED WATER SHORTAGE CONTINGENCY PLAN**

---

**WHEREAS**, the Trabuco Canyon Water District (“District” or “TCWD”) is a county water district organized and operating pursuant to California Water Code (“Water Code”) Sections 30000 and following; and

**WHEREAS**, the California Legislature enacted Assembly Bill 797 (Water Code Section 10610 *et seq.*, known as the Urban Water Management Planning Act, as amended (“Act”)) during the 1983-1984 Regular Session, which mandates that every supplier providing water for municipal purposes to more than 3,000 customers or supplying more than 3,000 acre feet of water annually, must prepare an Urban Water Management Plan and Water Shortage Contingency Plan (“Contingency Plan”), the primary objective of which is to ensure the appropriate level of reliability in the supplier’s water service to meet the needs of its customers during normal, dry and multiple dry years, and to ensure for the conservation and efficient use of water; and

**WHEREAS**, following the end of the most recent drought, the California Legislature modified the Act in 2018 to include additional water shortage planning requirements; and

**WHEREAS**, significant amendments to the Water Code, specifically Water Code Section 10632, now mandate new elements to Urban Water Management Plans, including Contingency Plans, which must include an annual drought risk assessment, evaluation of State Water Shortage Levels and Statewide water use prohibitions; and

**WHEREAS**, TCWD is an urban water supplier which is subject to the provisions and requirements of the Act; and

**WHEREAS**, Section 375 *et seq.* of the Water Code permits public entities which supply water at retail or wholesale to adopt and enforce a water conservation program to reduce the quantity of water used by the people therein for the purpose of conserving the water supplies of such public entity; and

**WHEREAS**, Section 350 *et seq.* of the Water Code permits the governing body of a distributor of a public water supply to declare a water shortage emergency condition to prevail within the area served by such distributor whenever it finds and determines that the ordinary demands and requirements of water consumers cannot be satisfied without depleting the water supply of the distributor to the extent there would be insufficient water for human consumption, sanitation and fire protection; and

**WHEREAS**, pursuant to Section 31000 *et seq.* of the Water Code, the District has the authority to adopt rules and regulations necessary to furnish sufficient water for any present or future beneficial use; and

**WHEREAS**, TCWD’s Urban Water Management Plan (“Plan”) is required to be periodically reviewed at least once every five years and TCWD shall make amendments or changes to the Plan which are indicated by the review; and

**WHEREAS**, the Plan must be updated, adopted, and submitted to the California Department of Water Resources (“DWR”) not later than July 1, 2021; and

**WHEREAS**, the Plan must be submitted to the California State Library, and the cities and county within which TCWD provides water, shall be provided with a copy of the Trabuco Canyon Water District Urban Water Management Plan Update (“2020 UWMP”), including the TCWD Water Shortage Contingency Plan, no later than 30 days after adoption thereof; and

**WHEREAS**, TCWD prepared for public review a draft TCWD Water Shortage Contingency Plan (“TCWD Contingency Plan”) as part of the Plan and held a properly noticed public hearing on June 21, 2021, with respect to the , including the Contingency Plan included therein, during which TCWD received community input on the Plan and the Contingency Plan, and considered the economic impacts of the 2020 UWMP and the Contingency Plan, including a method for determining TCWD’s urban water use target; and

**WHEREAS**, the Board of Directors (“Board”) of TCWD were furnished with copies of the Contingency Plan as part of their consideration of such 2020 UWMP; and

**WHEREAS, the Board has determined that the adoption of the Contingency Plan, as part of the 2020 UWMP, as provided for under Water Code Section 10632, at this time, is appropriate.**

**NOW, THEREFORE, THE BOARD OF DIRECTORS OF THE TRABUCO CANYON WATER DISTRICT DOES HEREBY RESOLVE, DETERMINE, AND ORDER AS FOLLOWS:**

**Section 1.** The foregoing recitals are true and correct and are incorporated herein by this reference.

**Section 2.** The Board of Directors hereby adopts the Contingency Plan, as part of the 2020 UWMP, which Contingency Plan is incorporated herein by this reference, and will implement the Contingency Plan in accordance with the terms set forth therein.

**Section 3.** The District Secretary of TCWD is hereby directed to submit the Contingency Plan, as a component of the 2020 UWMP, to the California Department of Water Resources, the California State Library, and any city or county within which TCWD provides water service, no later than 30 days from the date of adoption of this Resolution, as provided for under Water Code Section 10644(a)(1).

**Section 4.** The General Manager, the District Secretary, and the District’s staff and consultants, are authorized to take any and all other and further actions necessary or desirable to implement the directives and intention of this Resolution or to otherwise comply with the provisions of the Act.

[Remainder of this page intentionally left blank]

**ADOPTED, SIGNED AND APPROVED this 16<sup>th</sup> day of June, 2021.**

**TRABUCO CANYON WATER DISTRICT**

By: \_\_\_\_\_  
President/Vice President

By: \_\_\_\_\_  
District Secretary

DRAFT

STATE OF CALIFORNIA        )  
                                          ) ss.  
COUNTY OF ORANGE        )

I, Michael Perea, District Secretary of the Trabuco Canyon Water District, do hereby certify that the foregoing resolution was duly adopted by the Board of said District at a regular meeting of such Board held on the 16<sup>th</sup> day of June, 2021 of which meeting all of the members of the Board had due notice and at which a quorum thereof were present and acting throughout and for which notice and an agenda was prepared and posted as required by law and that at said meeting such resolution was adopted by the following vote:

AYES:

NOES:

ABSTAIN:

ABSENT:

\_\_\_\_\_  
District Secretary,  
Trabuco Canyon Water District

DRAFT

STATE OF CALIFORNIA        )  
                                          ) ss.  
COUNTY OF ORANGE        )

I, Michael Perea, District Secretary of the Trabuco Canyon Water District, do hereby certify that the foregoing is a full, true, and correct copy of Resolution No. 2021-1291 of such Board and that the same has not been amended, rescinded or repealed.

Dated this 16<sup>th</sup> day of June, 2021.

\_\_\_\_\_  
District Secretary,  
Trabuco Canyon Water District

DRAFT

**RESOLUTION NO. 2021-1292**

**RESOLUTION OF THE BOARD OF DIRECTORS  
OF THE TRABUCO CANYON WATER DISTRICT  
ADOPTING THE TRABUCO CANYON WATER DISTRICT  
2020 URBAN WATER MANAGEMENT PLAN UPDATE**

---

**WHEREAS**, the Trabuco Canyon Water District ("District") is a county water district organized and operating pursuant to the provisions of California Water Code ("Water Code") Sections 30000 and following; and

**WHEREAS**, the California Legislature enacted Assembly Bill 797 during the 1983-84 Regular Session of the California Legislature (enacting Water Code Sections 10610, *et. seq.*, and as amended subsequently, known as the "Urban Water Management Planning Act" hereinafter the "Act"), which mandates that every supplier providing water for municipal purposes to more than 3,000 customers, or supplying more than 3,000 acre-feet of water annually, prepare an Urban Water Management Plan, the primary objective of which is to plan for the conservation and efficient use of water; and

**WHEREAS**, the District is an urban supplier of water which is subject to the provisions and requirements of the Act; and

**WHEREAS**, the conservation and efficient use of urban water supplies are matters of Statewide concern; however, the planning for that use and the implementation of water supply management and use can best be accomplished at the local level; and

**WHEREAS**, the District previously prepared, considered, reviewed and adopted its Urban Water Management Plan ("Plan") and the District's 2015 Urban Water Management Plan Update pursuant to the provisions of the Act; and

**WHEREAS**, the Act requires that an urban water suppliers' Urban Water Management Plan be periodically reviewed at least once every five years and that the urban water supplier shall make any amendments or changes to such Urban Water Management Plan which are indicated by such review(s); and

**WHEREAS**, the District has caused to be prepared the District's 2020 Urban Water Management Plan Update ("2020 UWMP") consistent with the provisions of the Act; and

**WHEREAS**, the 2020 UWMP must be adopted by the Board of Directors ("Board") of the District not later than July 1, 2021, following public review and completion of a public hearing, and that the adopted 2020 UWMP thereafter filed with the California Department of Water Resources ("DWR") within thirty (30) days following its adoption; and

**WHEREAS**, the District has therefore prepared and circulated for public review and inspection a draft of the 2020 UWMP for review and comment, including, but not limited to, provision of notice thereof on the District's website; and

**WHEREAS**, the District previously provided notice to various other public agencies that the District was in the process of preparing the 2020 UWMP, and concerning the public hearing thereon, consistent with the requirements of the Act, and invited consultation and comment on the 2020 UWMP; and

**WHEREAS**, the District conducted a properly noticed a public hearing regarding the consideration of the 2020 UWMP on June 16, 2021, at which time a full and fair hearing on such matter was held and completed; and

**WHEREAS**, the 2020 UWMP is a general information document that is intended to provide an analysis of the current and alternative water demand and supplies and conservation activities of the District, including effects of and measures for coping with short-term and chronic water shortages which may occur within the District's boundaries; and

**WHEREAS**, the Board, having considered the Plan and, the 2020 UWMP thereto, desires to approve of the 2020 UWMP, direct its filing with the DWR and take related actions.

**NOW, THEREFORE, THE BOARD OF DIRECTORS OF TRABUCO CANYON WATER DISTRICT DOES HEREBY RESOLVE, DETERMINE AND ORDER AS FOLLOWS:**

**Section 1.** The foregoing recitals are true and correct and are incorporated herein by this reference.

**Section 2.** The 2020 UWMP, attached hereto and incorporated herein by this reference, is hereby adopted as the 2020 Urban Water Management Plan Update of the District pursuant to the requirements and provisions of the Act.

**Section 3.** The Secretary of the District is authorized and directed to file copies of the 2020 UWMP with the DWR and the California State Library pursuant to the provisions of Water Code Section 10644 within thirty (30) days after adoption of this Resolution. Copies of the 2020 UWMP shall be available for public review during normal business hours at the District's administrative offices consistent with the provisions of the Act.

**Section 4.** The General Manager, the District Secretary, and the District's staff and consultants are authorized to take any and all other and further actions necessary or desirable to implement the directives and intention of this Resolution or to otherwise comply with the provisions of the Act.

[Remainder of this page intentionally left blank]

ADOPTED, SIGNED AND APPROVED this 16<sup>th</sup> day of June, 2021.

**TRABUCO CANYON WATER DISTRICT**

By: \_\_\_\_\_  
President/Vice President

By: \_\_\_\_\_  
District Secretary

DRAFT

STATE OF CALIFORNIA            )  
                                                  ) ss.  
COUNTY OF ORANGE            )

I, Michael Perea, District Secretary of the Trabuco Canyon Water District, do hereby certify that the foregoing resolution was duly adopted by the Board of said District at a regular meeting of such Board held on the 16<sup>th</sup> day of June, 2021 of which meeting all of the members of the Board had due notice and at which a quorum thereof were present and acting throughout and for which notice and an agenda was prepared and posted as required by law and that at said meeting such resolution was adopted by the following vote:

AYES:

NOES:

ABSTAIN:

ABSENT:

\_\_\_\_\_  
District Secretary,  
Trabuco Canyon Water District

DRAFT

STATE OF CALIFORNIA            )  
                                                  ) ss.  
COUNTY OF ORANGE            )

I, Michael Perea, District Secretary of the Trabuco Canyon Water District, do hereby certify that the foregoing is a full, true, and correct copy of Resolution No. 2021-1292 of such Board and that the same has not been amended, rescinded or repealed.

Dated this 16<sup>th</sup> day of June, 2021.

\_\_\_\_\_  
District Secretary,  
Trabuco Canyon Water District

DRAFT

**ATTACHMENT**

**COPY OF 2020 URBAN WATER MANAGEMENT PLAN UPDATE**

DRAFT

**TRABUCO CANYON WATER DISTRICT  
REGULAR BOARD MEETING | JUNE 16, 2021**

**ACTION CALENDAR**

**ADMINISTRATIVE MATTERS**

**ITEM 7: DISCUSSION AND POSSIBLE ACTION(S) CONCERNING THE CORONAVIRUS, INCLUDING SAFETY OF DISTRICT SERVICES AND EMPLOYEES, AND IMPACT TO BOARD & COMMITTEE MEETINGS**

---

**DISTRICT RESPONSE EFFORTS**

On June 15, 2021, the state will transition to “Beyond the Blueprint” where all industry and business sectors listed in the current Blueprint system may return to usual operations with no capacity limits or physical distancing requirements, with limited exceptions for mega events. However, this is for the general public and the workplace setting is still governed by Cal/OSHA’s COVID-19 Emergency Temporary Standards (ETS). The ETS currently in effect will most likely be revised on June 17 to align better with new State Health Department mask guidelines effective June 15.

The Governor did announce that the Executive Order modifying the Brown Act to allow public meetings to be held remotely will continue for the time being. The Governor will provide notice of the termination of the Executive Order with enough notice so that public entities can make the transition back to in-person only meetings.

The District’s offices remain closed to the public and community groups and staff recommends the Board reassess public accessibility no earlier than the July regular board meeting to account for the adaptation to the June 15 reopening.

**FUNDING SOURCE:**

Unknown at this time.

**FISCAL IMPACT**

Unknown at this time.

**ENVIRONMENTAL COMPLIANCE:**

Not applicable.

**COMMITTEE STATUS:**

This matter was not reviewed at the Committee level.

**RECOMMENDED ACTIONS:**

*Receive information at the time of the Board meeting and take action(s) as deemed appropriate.*

**EXHIBIT(S):**

None

**CONTACTS (staff responsible): PALUDI/PEREA**

**TRABUCO CANYON WATER DISTRICT  
REGULAR BOARD MEETING | JUNE 16, 2021**

**ACTION CALENDAR**

**ADMINISTRATIVE MATTERS**

**ITEM 8: DISCUSSION AND POSSIBLE ACTION(S) RELATED TO THE PROPOSED PALOMA SQUARE DEVELOPMENT (DOVE CANYON PLAZA) AND OTHER RELATED MATTERS**

---

Trabuco Canyon Water District (TCWD or District) owns the Administration Facility and the property upon which it resides; the property is adjacent to the Dove Canyon Plaza commercial center. On July 24, 2019, Dove Canyon Recovery Acquisition, LLC (DCRA), the owner of Dove Canyon Plaza, with their consultant William Lyon Homes (now Taylor Morrison) submitted a proposal to the City of Rancho Santa Margarita (City) for a change in use from commercial to residential. The proposed project is titled "Paloma Square." The initial submittal to the City, and all subsequent submittals, project information, and correspondence between City and William Lyon Homes/Taylor Morrison related to Paloma Square are available on the City's website. The District's website, under the "Community" tab, also includes information and correspondence regarding proposed project.

**FUNDING SOURCE:**

General Fund.

**FISCAL IMPACT:**

None

**ENVIRONMENTAL COMPLIANCE:**

Not applicable.

**COMMITTEE STATUS:**

This matter was reviewed with the Engineering/Operational Committee.

**RECOMMENDED ACTIONS:**

*Receive information at the time of the Board meeting and take action(s) as deemed appropriate.*

**EXHIBIT(S):**

None

**CONTACTS (staff responsible): PALUDI/PEREA/LAUSTEN**

**TRABUCO CANYON WATER DISTRICT  
REGULAR BOARD MEETING | JUNE 16, 2021**

**ACTION CALENDAR**

**ADMINISTRATIVE MATTERS**

**ITEM 9: AUTHORIZE ACTIONS FOR TRABUCO CANYON WATER DISTRICT’S FISCAL YEAR 2021/2022 UNDEVELOPED LAND/WATER STANDBY CHARGES (ASSESSMENT) AND SET PUBLIC HEARING**

**BACKGROUND**

The Trabuco Canyon Water District (District) annually levies an Undeveloped Land/Water Standby Charge (Standby Charge), currently set at \$15.00 per acre or portion thereof, for undeveloped land within the District’s boundaries. The standby charge is levied to cover the fixed costs of the existing District water system to make water available, when requested, to serve currently undeveloped land.

At the March 18, 1997, Regular Board Meeting, District general legal counsel addressed the standby charge as it related to Proposition 218 (adopted in November, 1996), noting that the District can continue to levy the standby charge if the amount of the charge is not increased over the previously existing rate (\$15.00) and if the standby charge was levied using the same methodology. Under the provisions of Proposition 218, the water standby charges are considered to be “assessments.” Provided that the amount of water standby charges (Assessments) do not increase, they are “grandfathered” under Proposition 218 and do not have to comply with the more extensive assessment proceedings and voting process required for new assessments under Proposition 218.

The procedure for the adoption of the water standby charge (assessment) for Fiscal Year 2021/2022 is shown below:

DATE	DESCRIPTION OF ACTION
June 16, 2021	At the Regular Board Meeting, the Board directs District staff to prepare the required written Water Standby Charge (Assessment) Report (“Report”). The Report contains a description of each parcel of real property and the amount of the Water Standby Charges (Assessments) for each parcel for the year. The Board directs District staff to agendize a Public Hearing concerning the proposed Water Standby Charges (Assessments) Report to be held at the July 16, 2021 Regular Board Meeting.
Late June 2021	The Notice to Property Owners (“Notice”) is published in conformance with the statutory requirements, once a week for two successive weeks in the Orange County Register newspaper. The Notice is mailed <b>not less than fifteen (15) days prior</b> to the public hearing (July 21, 2021) to each effected property owner within the District. The form of the Notice to Property Owners is attached. At the time the Notice is mailed, the Report must be made available for public review upon request.
July 21, 2021	A Public Hearing is held for public comments concerning the proposed Fiscal Year 2021/2022 Water Standby Charges (Assessments). Following the conclusion of the Public Hearing, the Board considers a Resolution to set and collect the Water Standby Charges (Assessments) for Fiscal Year 2021/2022.

**FUNDING SOURCE:**

Levy and collection of the annual water standby charges results in an estimated \$45,000 annual credit to the District’s General Fund.

**TRABUCO CANYON WATER DISTRICT  
REGULAR BOARD MEETING | JUNE 16, 2021**

**FISCAL IMPACT**

The cost of completing the report, publication and mailing of the Notice - *Approximately \$3,500*

**ENVIRONMENTAL COMPLIANCE:**

Not applicable

**ENVIRONMENTAL COMPLIANCE:**

Not applicable

**COMMITTEE STATUS:**

This matter was not reviewed at the Committee level.

**RECOMMENDED ACTION(S):**

1. *Authorize District staff to proceed with actions for setting the Fiscal Year 2021/2022 Undeveloped Land/Water Standby Assessment at \$15.00 per acre or portion thereof; and*
2. *Agendize Public Hearing and authorize District staff to furnish Notice of Public Hearing on Proposed Fiscal Year 2021/2022 Undeveloped Land/Water Standby Assessments for the July 21, 2021 Regular Board*

**EXHIBIT(S):**

1. DRAFT Trabuco Canyon Water District Notice of Fiscal Year 2021/2022 Undeveloped Land/Water Standby Assessment to Property Owners

**CONTACTS (staff responsible): PALUDI/PEREA**



## **NOTICE TO PROPERTY OWNERS WITHIN THE TRABUCO CANYON WATER DISTRICT SERVICE AREA**

---

Dear Property Owner:

The Trabuco Canyon Water District (*formerly named the Santa Ana Mountains County Water District*) plans to fix a water standby or availability assessment on all undeveloped land within the District for the fiscal year 2021/2022. This assessment will remain at \$15.00 per acre for undeveloped developable parcels over one acre or \$15.00 for each undeveloped parcel of less than one acre, per year.

This assessment or charge is being imposed by the District because the Board of Directors has determined that this is an equitable means of raising funds necessary to make water available to your property.

A report has been prepared and filed with the District that lists all undeveloped parcels of land and the assessment on each. This report is available for public inspection at the District Administration Facility during normal business hours. The District Administration Facility is located at:

**32003 Dove Canyon Drive  
Trabuco Canyon, California 92679  
(949) 858-0277**

The Board of Directors will hear and consider all public comments to this report at a public hearing to be held on **July 21, 2021** at **7:00 p.m.**, or as soon thereafter as the agenda permits, at the District Administration Facility at the above-stated address.

**TRABUCO CANYON WATER DISTRICT**

By: \_\_\_\_\_

Michael Perea

Secretary to the Board of Directors

**TRABUCO CANYON WATER DISTRICT  
REGULAR BOARD MEETING | JUNE 16, 2021**

**ACTION CALENDAR  
FINANCIAL MATTERS**

**ITEM 10: DISCUSSION AND ACTION CONCERNING TRABUCO CANYON WATER DISTRICT PROPOSED FISCAL YEAR 2021-22 GENERAL FUND AND CAPITAL IMPROVEMENT PROJECT (CIP) BUDGET**

The District fiscal year runs from each July 1 through each June 30. During the last quarter of each fiscal year, District staff reviews financial information and performs analyses relating to projected costs for the upcoming fiscal year in order to recommend a budget to the Board of Directors.

**PROPOSED GENERAL FUND BUDGET ASSUMPTIONS**

For FY 2021/2022, District staff has prepared the General Fund Budget with the following budgetary assumptions based on nine months of financial data in FY 2020/2021:

<b>FY2021/2022 BUDGETARY ASSUMPTIONS</b>	
<b>DESCRIPTION</b>	<b>% ADJUSTMENT</b>
TCWD Water Sales/Consumption	2.0%
MET Treated Rate	3.5%
MET Untreated Rate	2.8%
MWDOC Capacity Charges	12.0%
MWDOC Readiness to Serve Charge	(12.0%)
MWDOC Water Loss Control Program	Pending
MWDOC Water Education Program	(27.0%)
MWDOC Water Use Efficiency Programs	No Change
<b>Health Benefits</b>	
Health Benefits	7.0%
Dental Benefits	2.0%
Vision Benefits	2.0%
Life Insurance Benefits	2.0%
<b>Utilities</b>	
Electricity	4.0%
Chemicals	2.0%
Fuel	2.0%
Inflation	2.0%
Property Taxes	2.0%

*\*Actual increase of \$7,744 for the year; based on the District's overall MET rebate activity from year to year*

Total revenues proposed for the FY 2021/2022 budget equal \$12,039,300, a 9.3% increase compared to the projected results of the current FY 2020/2021. Total proposed expenses are \$12,256,900, an 7.8% increase compared to current fiscal year projected results. Overall, when capital contributions and debt service are accounted for, the proposed budget results in a net income of \$503,300. The District's total reserve balance will increase by \$503,300 in net income and an estimated \$4,680,000 in borrowing as planned in the 2019 rate study to help fund the CIP program. Total reserves ending balance is projected to be \$9,352,502.

**PROPOSED CAPITAL IMPROVEMENT PROJECTS, EQUIPMENT, & PROGRAM BUDGETS**

District staff prepares a list of proposed projects for the upcoming fiscal year in order to recommend a CIP budget to the Board of Directors. The FY 2021/2022 CIP budget is \$4,817,500 and includes 22 projects. Additional information may be provided at the time of the meeting.

**TRABUCO CANYON WATER DISTRICT  
REGULAR BOARD MEETING | JUNE 16, 2021**

**FUNDING SOURCE:**

General Fund

**FISCAL IMPACT:**

Proposed Fiscal Year 2021/2022 General Fund Budget:	\$ 12,256,900
Proposed Fiscal Year 2021/2022 Capital Improvement Projects, Equipment, and Program Budgets:	\$ 4,817,500

**ENVIRONMENTAL COMPLIANCE:**

Not applicable.

**COMMITTEE STATUS:**

This matter has been reviewed at the Committee level.

**RECOMMENDED ACTION:**

1. *Adopt Resolution No. 2021 - 1293– Resolution of the Board of Directors of Trabuco Canyon Water District of the Trabuco Canyon Water District Approving the General Fund District Budget for Fiscal Year 2021/2022 for an amount of \$12,256,900.*
2. *Adopt Resolution No. 2021 - 1294 - Resolution of the Board of Directors of Trabuco Canyon Water District of the Trabuco Canyon Water District Approving the Capital Improvement Project, Equipment, and Program Budgets for Fiscal Year 2021/2022 for an amount of \$4,817,500.*

**EXHIBIT(S):**

1. Proposed DRAFT Fiscal Year 2021/2022 Budget
  - a. Schedule A – Budget Summary
  - b. Schedule B – Operating Budget
  - c. Schedule C – Capital Improvement Program Budget
  - d. Schedule D – Projected Reserve Funds
2. DRAFT Resolution No. 2021 - 1293– Resolution of the Board of Directors of Trabuco Canyon Water District of the Trabuco Canyon Water District Approving the General Fund District Budget for Fiscal Year 2021/2022
3. DRAFT Resolution No. 2021 - 1294 - Resolution of the Board of Directors of Trabuco Canyon Water District of the Trabuco Canyon Water District Approving the Capital Improvement Project, Equipment, and Program Budgets for Fiscal Year 2021/2022

**CONTACTS (staff responsible): PALUDI/PEREA/LAUSTEN/WARNER**



**TCWD**  
**Proposed Budget Summary**  
**FY 2021/22**

*Schedule A*

	<b>A</b>		<b>B</b>		<b>C</b>
	<b>FY 20/21</b>		<b>FY 20/21</b>		<b>FY 21/22</b>
	<b>Adopted Budget</b>		<b>Projected Results</b>		<b>Proposed Budget</b>
<b>1 GENERAL FUND</b>					
2 Sources of Funds from Operating Budget (Revenues)	\$ 10,658,800	\$	11,014,300	\$	12,039,300
3 Uses of Funds from Budget* (Expenses)	(11,027,200)		(11,374,200)		(12,256,900)
<b>4 Surplus / (Deficit) Available to Fund CIP &amp; Debt Service</b>	<b>(368,400)</b>		<b>(359,900)</b>		<b>(217,600)</b>

*General Fund Cash Flow includes sources and uses of funds to operate the District's water, wastewater, recycled and reclaimed systems. General Fund Cash Flow does not include non-cash expenses such as depreciation, amortization, capital restricted revenues/expenses, or WRES (SRF) assessment revenues/expenses, all of which are not available to fund general operations. It does include Series C debt service, paid by General Fund.*

*\*Includes Series C principal payments, and major repairs in the CIP budget.*

<b>5 RESTRICTED CAPITAL CONSTRUCTION REVENUES - EXCLUDES DEVELOPER FEES &amp; GRANT REIMBURSEMENTS</b>					
<b>6 Water Reliability and Emergency Storage Fees (WRES)</b>					
7 WRES - Baker Treatment Plant	<i>a.</i>	\$ 373,400	\$	377,900	\$ 377,900
8 WRES - Reservoir/Distribution Funding	<i>b.</i>	\$ 54,100	\$	30,700	\$ 30,700
9 WRES - Wells Facilities	<i>c.</i>	\$ 406,800	\$	413,600	\$ 413,600

*a. Dedicated for the District's share of costs for the construction of the Baker Treatment Plant.*

*b. Dedicated for constructing a new reservoir and/or distribution improvements.*

*c. Dedicated for repayment of the State Revolving Fund (SRF) loan, which funded the construction of the Trabuco Creek Wells Facility.*



# TCWD Proposed Budget Detail FY 2021/22

*Schedule B*

	FY 2019/20 Actual Results	FY 2020/21 Adopted Budget	FY 2020/21 Projected Results	FY 2021/22 Proposed Budget	\$ Change	% Change
<b>1 Operating Revenue</b>						
2 Residential Water Revenues	\$ 3,244,641	\$ 3,497,400	\$ 3,710,000	\$ 4,116,200	\$ 406,200	10.9%
3 Business & Industrial Water Revenues	123,985	150,300	150,100	165,600	15,500	10.3%
4 Irrigation Water Revenues	763,726	823,400	964,300	1,075,200	110,900	11.5%
5 Stand-By Revenue	65,930	41,000	41,000	41,800	800	2.0%
6 Sanitation Revenue	1,918,114	1,859,400	1,830,900	1,964,200	133,300	7.3%
7 Recycled & Reclaimed Revenue	723,088	725,000	827,300	999,000	171,700	20.8%
8 Baker Treatment Plant Water Sales	1,210,433	1,469,100	1,344,100	1,383,500	39,400	2.9%
9 Other Operating Revenue	151,158	164,600	5,100	179,600	174,500	3421.6%
<b>10 Total Operating Revenue</b>	<b>8,201,075</b>	<b>8,730,200</b>	<b>8,872,800</b>	<b>9,925,100</b>	<b>1,052,300</b>	<b>11.9%</b>
<b>11 Non-Operating Revenue</b>						
12 Property Tax Unrestricted	1,936,412	1,707,400	1,966,200	2,006,200	40,000	2.0%
13 Interest Revenue	109,736	100,600	47,400	35,600	(11,800)	-24.9%
14 Development Services	-	-	-	-	-	-
15 Sale of Fixed Assets	9,584	50,000	46,100	-	(46,100)	-100.0%
16 Other Non-Operating Revenue	67,227	70,600	81,800	72,400	(9,400)	-11.5%
<b>17 Total Non-Operating Revenue</b>	<b>2,122,959</b>	<b>1,928,600</b>	<b>2,141,500</b>	<b>2,114,200</b>	<b>(27,300)</b>	<b>-1.3%</b>
<b>18 Total Revenues</b>	<b>10,324,034</b>	<b>10,658,800</b>	<b>11,014,300</b>	<b>12,039,300</b>	<b>1,025,000</b>	<b>9.3%</b>
<b>19 Operating Expenses</b>						
20 Source of Supply	2,103,788	2,198,100	2,271,800	2,262,400	(9,400)	-0.4%
21 Baker Treatment SOS Costs	1,046,475	1,155,300	1,201,700	1,287,700	86,000	7.2%
22 Water Related Direct Expenses	1,808,832	1,946,900	1,963,400	2,032,100	68,700	3.5%
23 Sanitation Direct Expenses	1,364,825	1,168,400	1,355,100	1,359,200	4,100	0.3%
24 Reclaimed & Recycled Expenses	454,442	446,700	458,800	468,300	9,500	2.1%
25 Salaries & Benefits	3,320,139	3,462,600	3,483,700	3,923,000	439,300	12.6%
26 CalPERS UAL & Pension Trust Contributions	452,254	222,100	216,200	590,500	374,300	173.1%
27 OPEB Trust Contributions & Paygo OPEB	112,319	309,100	309,300	206,100	(103,200)	-33.4%
28 Board Expenses	108,957	114,400	109,200	122,600	13,400	12.3%
<b>29 Total Operating Expenses</b>	<b>10,772,032</b>	<b>11,023,600</b>	<b>11,369,200</b>	<b>12,251,900</b>	<b>882,700</b>	<b>7.8%</b>
<b>30 Non-Operating Expenses</b>						
31 Other Non-Operating Expense	12,696	3,600	5,000	5,000	-	0.0%
<b>32 Total Non-Operating Expenses</b>	<b>12,696</b>	<b>3,600</b>	<b>5,000</b>	<b>5,000</b>	<b>-</b>	<b>0.0%</b>
<b>33 Total Expenses</b>	<b>10,784,728</b>	<b>11,027,200</b>	<b>11,374,200</b>	<b>12,256,900</b>	<b>882,700</b>	<b>7.8%</b>
<b>Net Income/(Loss) Before Capital</b>						
<b>34 Contributions &amp; Debt Service</b>	<b>(460,694)</b>	<b>(368,400)</b>	<b>(359,900)</b>	<b>(217,600)</b>	<b>142,300</b>	
<b>35 Capital Contributions &amp; Debt Service</b>						
36 WRES	833,511	834,300	822,200	822,200	-	
37 Developer Impact Fees	-	-	19,900	-	(19,900)	
38 Capital Contributions & Grants Proceeds	5,926,052	-	99,700	344,000	244,300	
39 Debt Principal, Interest & Issuance Costs	(230,381)	(230,300)	(230,300)	(445,300)	(215,000)	
<b>40 Total Capital Contributions &amp; Debt Service</b>	<b>6,529,182</b>	<b>604,000</b>	<b>711,500</b>	<b>720,900</b>	<b>9,400</b>	
<b>41 Net Income</b>	<b>\$ 6,068,488</b>	<b>\$ 235,600</b>	<b>\$ 351,600</b>	<b>\$ 503,300</b>	<b>\$ 151,700</b>	



**TCWD**  
**Proposed CIP Detail**  
**FY 2021/2022**

*Schedule C*

Item #	Project	Project Basis	Proposed
<b>WATER</b>			
1	PRV Improvements	Reliability	\$ 55,000
2	Valve Replacement Program	End of Service Life	37,500
3	DWTP Chlorine Building Improvement - Doors & Roof	Safety; End of Service Life	35,000
4	DWTP Office & Storage	Safety; End of Service Life	200,000
5	Live Oak Transmission Main Upgrade	Reliability	900,000
<b>WATER SUBTOTAL</b>			<b>1,227,500</b>
<b>DISTRICT-WIDE</b>			
6	SCADA System Upgrades	Reliability; End of Service Life	1,000,000
7	Meter Replacement Program	Water Use Efficiency	35,000
8	AMI/AMR System Implementation - USBR Grant Funded	Water Use Efficiency	600,000
9	District Facility Security Improvements	Security	100,000
10	Skiploader - AQMD Tier 1 Compliant	End of Life	100,000
11	Pump Replacement Program	End of Life	100,000
12	Generators (Grant - spend by Nov21)	Reliability	300,000
13	Master Plan and Condition Assessment Study	Reliability; Safety	600,000
14	Field Office Remediation (Excavation, French Drain, Retaining Wall)	Safety	20,000
<b>DISTRICT-WIDE SUBTOTAL</b>			<b>2,855,000</b>
<b>WASTEWATER / RECLAIMED / RECYCLED</b>			
15	Wet Well Recoating Program - Via Allegre, Barneburg, Bell Canyon - Sewer	General Maintenance	25,000
16	Manhole Recoating Program - Sewer	General Maintenance	20,000
17	PRV Vault Improvements Program - Reclaimed	General Maintenance	45,000
18	SLS Surge Tank Improvements/Rehabilitation Program (Barneburg & Bell Canyon) - Sewer	General Maintenance	25,000
19	Heritage SLS Improvements - Security, Asphalt, Piping, Bypass, Electrical	End of Service Life	240,000
20	Golf Club SLS Bypass Construction - Sewer ByPass, MCC, Wet Well Rehab	End of Service Life	150,000
21	WWTP Headworks Climber Screen - Sewer	End of Service Life	110,000
22	RW PS Header, Filters, Pump	End of Service Life	120,000
<b>WASTEWATER / RECLAIMED / RECYCLED SUBTOTAL</b>			<b>735,000</b>
<b>TOTAL PROPOSED CIP</b>			<b>\$ 4,817,500</b>

*\*The District is projected to issue \$6.4M in debt per the most recent Rate Study to fund current and future capital projects.*



**TCWD**  
**Projected Reserve Balances**  
**FY 2021/22**

*Schedule D*

	Beginning Balance	Net Cash Changes from P&L	WRES	Capital Contributions / New Debt	CIP / Fixed Assets	Adjustments	Projected Ending Balance
<b>Unrestricted</b>							
1100 Internal Financing	\$ (553,464)	\$ 503,300	\$ (615,819)	\$ 6,744,000	\$ (4,641,817)	\$ 85,522	\$ 1,521,722
1102 CIC DIF	-	-	-	-	-	-	-
1103 Water Storage DIF	1,051,427	-	-	-	-	-	1,051,427
1104 Sanitation DIF	(1,363,632)	-	-	-	(38,183)	-	(1,401,815)
<b>Total Unrestricted</b>	<b>(865,670)</b>	<b>503,300</b>	<b>(615,819)</b>	<b>6,744,000</b>	<b>(4,680,000)</b>	<b>85,522</b>	<b>1,171,334</b>
<b>Restricted</b>							
1105 WRES - Wells	1,226,621	-	183,219	-	-	-	1,409,840
1106 WRES - Treatment	-	-	377,900	-	-	-	377,900
1107 WRES - Res/Dist	2,600,440	-	30,700	-	-	-	2,631,140
1108 RD#5	75,779	-	-	-	-	-	75,779
1109 Goren Deposit	118,850	-	-	-	-	-	118,850
1111 Developer Deposit	-	-	-	-	-	-	-
1112 District Capital Projects	-	-	-	-	-	-	-
1009 SRF Loan	243,165	-	24,000	-	-	-	267,165
<b>Total Restricted</b>	<b>4,264,856</b>	<b>-</b>	<b>615,819</b>	<b>-</b>	<b>-</b>	<b>-</b>	<b>4,880,675</b>
<b>Target</b>							
1114 Water Rate Stab.	684,080	-	-	-	-	108,750	792,830
1115 Sewer Rate Stab.	726,160	-	-	-	-	(178,800)	547,360
1116 Working Capital	1,975,776	-	-	-	-	(15,472)	1,960,304
<b>Total Target</b>	<b>3,386,016</b>	<b>-</b>	<b>-</b>	<b>-</b>	<b>-</b>	<b>(85,522)</b>	<b>3,300,494</b>
<b>Grand Total</b>	<b>\$ 6,785,202</b>	<b>\$ 503,300</b>	<b>\$ -</b>	<b>\$ 6,744,000</b>	<b>\$ (4,680,000)</b>	<b>\$ -</b>	<b>\$ 9,352,502</b>

**RESOLUTION NO. 2021-1293  
RESOLUTION OF THE BOARD OF DIRECTORS  
OF THE TRABUCO CANYON WATER DISTRICT  
APPROVING THE GENERAL FUND DISTRICT BUDGET  
FOR FISCAL YEAR 2021/2022**

---

**WHEREAS**, the Board of Directors of the Trabuco Canyon Water District ("TCWD") has reviewed the financial affairs of the District and has reviewed the proposed budget for the fiscal year 2021/2022; and

**WHEREAS**, the Board of Directors desires at this time to approve the General Fund District Budget for the fiscal year 2021/2022.

**NOW, THEREFORE, THE BOARD OF DIRECTORS OF TCWD DOES HEREBY RESOLVE, DETERMINE AND ORDER AS FOLLOWS:**

**Section 1.** That the General Fund District Budget, including the components thereof, for the fiscal year 2021/2022 be and the same hereby is approved by this Board of Directors. Said budget in the amount of **\$12,256,900** including operational and maintenance expenses and excluding depreciation expense, and the employee classifications and pay table referenced and contained therein, shall be placed on file with the Treasurer of TCWD and is by this reference incorporated herein.

**Section 2.** That the Treasurer or Secretary of TCWD be and the same is hereby authorized to file copies of said budget with such other public agencies as may be necessary.

**Section 3.** Certification is hereby made that the tax rates of TCWD are levied in accordance with Sections 93(a) and Section 97.65 of the Revenue and Taxation Code.

ADOPTED, SIGNED AND APPROVED this 16<sup>th</sup> day of June 2021.

**TRABUCO CANYON WATER DISTRICT**

By: \_\_\_\_\_  
President/Vice President

By: \_\_\_\_\_  
District Secretary

STATE OF CALIFORNIA        )  
                                          ) ss.  
COUNTY OF ORANGE        )

I, Michael Perea, District Secretary of the Trabuco Canyon Water District, do hereby certify that the foregoing resolution was duly adopted by the Board of said District at a regular meeting of such Board held on the 16<sup>th</sup> day of June 2021, of which meeting all of the members of the Board had due notice and at which a quorum thereof were present and acting throughout and for which notice and an agenda was prepared and posted as required by law and that at said meeting such resolution was adopted by the following vote:

AYES:

NOES:

ABSTAIN:

ABSENT:

\_\_\_\_\_  
District Secretary,  
Trabuco Canyon Water District

DRAFT

STATE OF CALIFORNIA        )  
                                          ) ss.  
COUNTY OF ORANGE        )

I, Michael Perea, District Secretary of the Trabuco Canyon Water District, do hereby certify that the foregoing is a full, true and correct copy of Resolution No. 2021-1293 of such Board and that the same has not been amended, rescinded or repealed.

Dated this 16<sup>th</sup> day of June 2021.

---

District Secretary,  
Trabuco Canyon Water District

DRAFT

**RESOLUTION NO. 2021-1294  
RESOLUTION OF THE BOARD OF DIRECTORS  
OF THE TRABUCO CANYON WATER DISTRICT  
APPROVING THE CAPITAL IMPROVEMENT PROJECTS,  
EQUIPMENT, AND PROGRAM BUDGETS FOR FISCAL YEAR 2021/2022**

---

**WHEREAS**, the Board of Directors of the Trabuco Canyon Water District ("TCWD") has reviewed the financial affairs of the District and has reviewed the proposed budgets for the fiscal year 2021/2022; and

**WHEREAS**, the Board of Directors desires at this time to approve the Capital Improvement Program Budget for the fiscal year 2021/2022.

**NOW, THEREFORE, THE BOARD OF DIRECTORS OF TCWD DOES HEREBY RESOLVE, DETERMINE AND ORDER AS FOLLOWS:**

**Section 1.** That the Capital Improvement Program Budget for the fiscal year 2021/2022 be and the same hereby is approved by this Board of Directors. Said budget in the amount of **\$4,817,500** shall be placed on file with the Treasurer of TCWD and is by this reference incorporated herein.

**Section 2.** That the Treasurer or Secretary of TCWD be and the same is hereby authorized to file copies of said budget with such other public agencies as may be necessary.

**Section 3.** Certification is hereby made that the tax rates of TCWD are levied in accordance with Sections 93(a) and Section 97.65 of the Revenue and Taxation Code.

ADOPTED, SIGNED AND APPROVED this 16th day of June 2021.

**TRABUCO CANYON WATER DISTRICT**

By: \_\_\_\_\_  
President/Vice President

By: \_\_\_\_\_  
District Secretary

STATE OF CALIFORNIA        )  
                                          ) ss.  
COUNTY OF ORANGE        )

I, Michael Perea, District Secretary of the Trabuco Canyon Water District, do hereby certify that the foregoing resolution was duly adopted by the Board of said District at a regular meeting of such Board held on the 16th day of June 2021, of which meeting all of the members of the Board had due notice and at which a quorum thereof were present and acting throughout and for which notice and an agenda was prepared and posted as required by law and that at said meeting such resolution was adopted by the following vote:

AYES:

NOES:

ABSTAIN:

ABSENT:

\_\_\_\_\_  
District Secretary,  
Trabuco Canyon Water District

DRAFT

STATE OF CALIFORNIA        )  
                                          ) ss.  
COUNTY OF ORANGE        )

I, Michael Perea, District Secretary of the Trabuco Canyon Water District, do hereby certify that the foregoing is a full, true and correct copy of Resolution No. 2021-1294 of such Board and that the same has not been amended, rescinded or repealed.

Dated this 16th day of June 2021.

---

District Secretary,  
Trabuco Canyon Water District

DRAFT

**TRABUCO CANYON WATER DISTRICT  
REGULAR BOARD MEETING | JUNE 16, 2021**

**ACTION CALENDAR  
FINANCIAL MATTERS**

**ITEM 11: DISCUSSION AND ACTION CONCERNING AN INCREASE IN THE SPENDING LIMIT TO AGREEMENT WITH SPECIAL COUNSEL**

---

The law firm of Hanson Bridgett, LLP (HB) is providing legal services to the District in the capacity of Special Counsel. HB's services are focused primarily on real property related matters but include other areas as directed by the Board of Directors or the General Manager. HB's services are under a professional services contract with the District entered into in June 2020. The original budget for this contract was \$50,000. In anticipation of increased activity related to the District's real properties, staff recommends an increase in the spending authority related to the agreement with HB in the amount of \$75,000.

**FUNDING SOURCE:**

General Fund.

**FUNDING SOURCE:**

General Fund.

**FISCAL IMPACT:**

Original Contract Amount:	\$ 50,000
Proposed increase budget:	\$ 75,000
<i>Total Fiscal Impact:</i>	<i>\$125,000</i>

**ENVIRONMENTAL COMPLIANCE:**

Not applicable.

**COMMITTEE STATUS:**

This matter was reviewed with the Finance/Audit Committee.

**RECOMMENDED ACTION:**

*Authorize an increase in the spending limit to Agreement with Hanson Bridgett LLP for Special Counsel Legal Services in an amount of \$75,000 for a total not-to-exceed amount of \$125,000.*

**EXHIBIT(S):**

None

**CONTACTS (staff responsible): PALUDI/PEREA**

**TRABUCO CANYON WATER DISTRICT  
REGULAR BOARD MEETING | JUNE 16, 2021**

**ACTION CALENDAR  
FINANCIAL MATTERS**

**ITEM 12: APPROVAL OF PROFESSIONAL SERVICES CONTRACT WITH FIELDMAN ROLAPP & ASSOCIATES FOR FINANCIAL ADVISORY SERVICES**

---

Trabuco Canyon Water District's (District) current five-year rate plan identifies the need for the District to issue debt to balance reserves while funding the Capital Improvement Program. The plan recommends the use of debt proceeds during Fiscal Year Ending (FY) 2022 and FYE 2024. With FYE 2022 approaching and the cost of borrowing still favorable, staff is recommending acting soon on the procurement of financial advisory services to assist the District in navigating the borrowing process and securing the lowest financing cost. Having a municipal advisor is important because they must act in a fiduciary capacity solely as agent to the District as the issuer of debt.

Fieldman Rolapp & Associates (FRA) is an independent municipal advisory firm that represents cities, counties, school districts, water agencies and other utilities. FRA is a local Orange County firm based in Irvine and has previously done work for the District in the 1990s. FRA is well-suited to provide advisory services to the District and the General Manager is recommending entering into a professional services agreement with FRA up to \$25,000 on a time and materials basis.

**FUNDING SOURCE:**

General Fund.

**FISCAL IMPACT:**

Up to \$25,000.

**ENVIRONMENTAL COMPLIANCE:**

Not applicable.

**COMMITTEE STATUS:**

This matter was not reviewed with a committee.

**RECOMMENDED ACTION:**

*Authorize the General Manager to enter into a professional services agreement with Fieldman Rolapp and Associates for Financial Advisory Services in an amount not-to-exceed \$25,000.*

**EXHIBIT(S):**

None

**CONTACTS (staff responsible): PALUDI/BYERRUM**

**TRABUCO CANYON WATER DISTRICT  
REGULAR BOARD MEETING | JUNE 16, 2021**

**ACTION CALENDAR  
ENGINEERING MATTERS**

**ITEM 13: DISCUSSION AND POSSIBLE ACTION(S) CONCERNING HERITAGE SEWER LIFT STATION IMPROVEMENTS**

---

Trabuco Canyon Water District (District) owns and operates the Heritage Sewer Lift Station (Heritage SLS) is located on Heritage Drive between Robinson Ranch Road and Silvertree Lane in the Trabuco Highlands Community (Exhibit 1). The Heritage SLS is a critical pump station that conveys pumped wastewater flows from a portion of the lower Dove Canyon community, Rancho Cielo community (from Via Allegre SLS), Walden Homes, Trabuco Marketplace, Dahlia Court community, and lower Robinson Ranch (from Plano Trabuco SLS) via a sewer force main. The facility also receives gravity sewer flows from the upper Robinson Ranch community and Trabuco Highlands community, and serves as the final pump station of the sanitary sewer system before the Robinson Ranch Wastewater Treatment Plant (WWTP).

For Fiscal Year 2020-2021, Heritage SLS is budgeted for a site and security upgrade project which includes a block wall, drainage repairs, paving and a new gate; however, during the design, staff re-evaluated the station due to ground subsidence around an existing manhole/sewer pipeline and operations request of the installation of a sewer by-pass valve assembly for emergency and maintenance work. Working with DMc Engineering, the District has completed the site and security design. Staff proposes contracting with JIG Consultants for the remaining work due to immediate need to make these repairs and the responsiveness of the Consultant on other projects (Exhibit 2).

**FUNDING SOURCE:**

General Fund.

**FISCAL IMPACT:**

\$420,000 (FY20-21 & FY21-22).

**ENVIRONMENTAL COMPLIANCE:**

Notice of Exemption

**COMMITTEE STATUS:**

This matter was reviewed with the Engineering/Operational Committee.

**RECOMMENDED ACTION:**

*Authorize the General Manager to ratify a Contract with JIG Consultants for Engineering Services for Heritage Lift Station Bypass and Piping Improvements in the amount of \$43,440.*

**EXHIBIT(S):**

1. Project Site Map and Site Photos
2. JIG Proposal - Engineering Design Services for Heritage Lift Station Improvements

**CONTACTS (staff responsible): PALUDI/PEREA/LAUSTEN**



**Project Location**



**Location Map**

 Area of Work

**Heritage Sewer Lift Station**

Address: 21494 Plano Trabuco Road  
Trabuco Canyon CA 92679

# HERITAGE SEWER LIFT STATION REPAIRS & IMPROVEMENTS

Trabuco Canyon Water District  
June 2, 2021 E&O Committee



**Existing Site**



**Sewer Pipeline Sag**

# Manhole and Valves Undermined





May 17, 2021

**Lorrie Lausten**  
**Trabuco Canyon Water District**  
32003 Dove Canyon Drive  
Trabuco Canyon, CA 92679

**Subject: Proposal for Engineering Design Services**  
**Heritage Lift Station Bypass Structure Improvements**

Dear Lorrie:

As a follow up to our meeting with DMc Engineering on April 16, 2021 regarding the proposed improvements at the Heritage Lift Station, JIG Consultants (JIG) prepared this proposal for improvements related to the lift station's bypass structure. As discussed, the design and construction plans resulting from this assignment will be coordinated with and incorporated into DMc Engineering's construction plan set for Miscellaneous Improvements at the Heritage Lift Station.

The following is our understanding of the required improvements at the lift station to bypass the existing wet well.

1. Evident from available CCTV information, the existing 8-inch influent sewer pipe has settled at multiple locations with excessive sags. The District intends to replace this sewer reach in its entirety, from the existing manhole on Heritage Avenue to the existing wet well. The approximate length of the subject sewer reach is 120 lineal feet.

In order to construct the proposed 8-inch influent sewer, a temporary bypass will be constructed from the subject manhole to the existing wet well. The bypass will include an outlet pipe plug and a temporary underground gravity pipe from the manhole to the lift station.

2. The existing circular wet well adjacent to the lift station has settled and is out of plumb. Further, the circular wet well is unlined with no protection for hydrogen sulfide that would develop from sewage gas. The inlet and outlet sewers to the circular wet well are not in their ideal configuration with gate valves for inlet and outlet sewage control. The District intends to upgrade the circular wet well to allow a trailer mounted bypass pump to take suction from the structure. Alternatives for consideration are as follows:

- A. Construct a new manhole on the proposed 8-inch influent sewer with dual outlet pipes. The first outlet pipe will discharge to the existing lift station wet well. The second outlet pipe will be set at a higher invert elevation and will discharge to a bypass structure. A normally closed sluice gate will be installed inside the bypass structure to control the flow of sewage. The depth of the bypass structure will be based on the lift station capacity and operating conditions.

In order to bypass the lift station wet well, the District will open the sluice gate and install a temporary plug on the proposed manhole's first outlet pipe.

With this alternative, the existing circular wet well may be salvaged and reused, provided it is stable and is lined with Raven 405 (polyurethane lining). If the existing circular wet well is compromised, a new bypass structure will be constructed.

- B. Demolish the existing circular wet well. Construct a new bypass structure on the proposed 8-inch influent sewer. The depth of the bypass structure will be based on the lift station capacity and operating conditions. The bypass structure will have an outlet pipe set at its invert which will discharge to the lift station wet

318 W. Katella Avenue, Suite A  
Orange, CA 92867

Office (714) 978.4407  
Fax (714) 908.4654  
[www.jigconsultants.com](http://www.jigconsultants.com)

well. A normally open sluice gate will be installed on the outlet pipe inside the bypass structure.

In order to bypass the lift station wet well, the District will only need to close the sluice gate.

3. The Heritage Lift Station’s Pump #3 was retrofitted by District staff to accept sewage from the existing circular wet well. Unfortunately, the resulting pipe and pump configuration introduces air into the pump volute which will ultimately result in its cavitation.

With the improvements previously described, the piping inside the dry well will be removed and the existing Pump #3 will be salvaged.

It is our understanding that all other improvements at the Heritage Lift Station will be designed by DMC Engineering. This includes paving, grading, perimeter and retaining walls, and miscellaneous site improvements. This also includes modifications to the existing force main for the temporary bypass piping assembly.

## SCOPE OF WORK

### 1. Project Management, Administration and Meeting

Perform project administration and management throughout the project duration. Attend one project meeting to discuss project status and collect District comments.

### 2. Site Visit and Collect Information

Attend one site visit to collect information and validate the recommended bypass improvements. Take measurements and photos inside the dry well and the circular wet well. Confirm the amount of sewage discharging to the Heritage Lift Station from the manhole at Heritage Avenue.

### 3. Flow Monitoring for Existing Manhole

Subcontract with Utility Systems (US<sup>3</sup>) to perform 7 day sewer flow monitoring of the existing manhole on Heritage Drive. See attached proposal from US<sup>3</sup>. Summarize results of the flow monitoring and submit to the District.

### 4. Review Design of Bypass Piping Assembly

Coordinate with DMC Engineering for design of the Bypass Piping Assembly. Provide comments and recommend modifications to its construction plans.

### 5. Preparation of Bid Documents

Complete engineering design of the proposed improvements as previously described. Submit full sized pdf digital copies of the 75% milestone submittal including construction plans, technical specifications, and cost estimate.

The construction plan set will include the following sheets:

<u>Sheet No.</u>	<u>Description</u>
C-1	Site Demolition Plan and Temporary Bypass Plan
C-2	Plan and Profile of 8-inch Influent Sewer
C-3	Mechanical Improvements at Dry Pit
C-4	Bypass Structure Plan and Sections
C-5	Miscellaneous Civil and Mechanical Details
C-6	Miscellaneous Civil and Mechanical Details

Construction plans will be prepared using the latest version of AutoCAD. DMC Engineering will provide AutoCAD drawings of the topographic survey and title block.

Submit full sized pdf copies of the 100% milestone submittal. The 100% milestone plans will incorporate District comments received from the 75% milestone submittal. The 100% milestone submittal will include the technical specifications and an engineer's estimate of probable construction costs.

Submit stamped and signed bond set of plans and technical specifications for District signatures. The final AutoCAD electronic files and full-sized PDF files shall be submitted to District on USB drive.

### ASSUMPTIONS AND EXCLUSIONS

The following are assumptions and exclusions to this proposal.

- A. The District will provide sewer flow information from the subject manhole at Heritage Avenue.
- B. The District will provide as-builts of the lift station including pump operating conditions.
- C. DMc Engineering will provide topographic base map of the project site including record drawings for existing utilities.
- D. The bypass structure will be a precast concrete structure and will not require structural design.
- E. The bypass structure will not have level or flow instruments. Electrical and instrumentation design is not included.
- F. This proposal is limited to civil and mechanical engineering design of the work described.
- G. Potholing of existing utilities is not included.
- H. Geotechnical investigations of subsurface conditions are not included.
- I. Bid phase services are not included.
- J. Construction administration services are not included.

### FEE SUMMARY

JIG will complete the above Scope of Work for a total consultant fee of **\$43,440**. A breakdown of the fee is presented in the attached Fee Proposal.

We appreciate this opportunity to continue our excellent relationship with the District. If you have questions regarding this proposal, please do not hesitate to contact our office.

Sincerely,

**JIG** CONSULTANTS



Joseph Gutierrez, PE, PMP  
President / Senior Project Manager

Enc.

**TRABUCO CANYON WATER DISTRICT**  
 Engineering Design Services - Heritage Lift Station Bypass Structure Improvements

**Fee Proposal**

Task	Description	Project Mgr.		Project Engineer		CAD Designer		Admin		Subtotal	Direct Costs	Sub.	Total Fee
		Hrly Rate	\$160	Hrly Rate	\$140	Hrly Rate	\$105	Hrly Rate	\$50				
		Hours	Fee	Hours	Fee	Hours	Fee	Hours	Fee			US3	
1	Project Management, Administration and Meeting	16	\$2,560	0	\$0	0	\$0	0	\$0	\$2,560	\$0	\$0	\$2,560
2	Site Visit and Collect Information	8	\$1,280	8	\$1,120	0	\$0	0	\$0	\$2,400	\$70	\$0	\$2,470
3	Flow Monitoring of Existing Manhole	0	\$0	0	\$0	0	\$0	0	\$0	\$0	\$0	\$3,590	\$3,590
4	Review Design of Bypass Piping Assembly	8	\$1,280	0	\$0	0	\$0	0	\$0	\$1,280	\$0	\$0	\$1,280
5	Preparation of Bid Documents	22	\$3,520	104	\$14,560	142	\$14,910	8	\$400	\$33,390	\$150	\$0	\$33,540
<b>TOTAL</b>		<b>54</b>	<b>\$8,640</b>	<b>112</b>	<b>\$15,680</b>	<b>142</b>	<b>\$14,910</b>	<b>8</b>	<b>\$400</b>	<b>\$39,630</b>	<b>\$220</b>	<b>\$3,590</b>	<b>\$43,440</b>



# Temporary Sewer Flow Monitoring Proposal

For Jig Consultants  
JIG\_051321

Utility Systems, Science & Software, Inc.  
601 Parkcenter Drive, Ste 209  
Santa Ana, CA 92705  
[www.uscubed.com](http://www.uscubed.com)  
Toll Free: 1-855-872-8233  
Office: 714-564-3494

**Created by:**

Sheila Trisnojoyo  
Utility Systems Science & Software, Inc.  
[sheila.trisnojoyo@uscubed.com](mailto:sheila.trisnojoyo@uscubed.com)

**Prepared for:**

Joseph Gutierrez  
Jig Consultants  
[JGutierrez@jigconsultants.com](mailto:JGutierrez@jigconsultants.com)

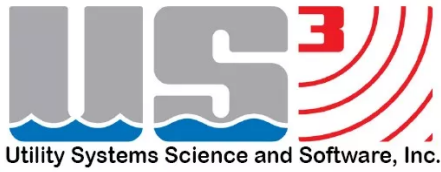

May 13, 2021

Jig Consultants  
318 West Katella Avenue Suite A  
Orange, California 92867

Attention: Joseph Gutierrez

Subject: Temporary Sewer Flow Monitoring

Hello Joseph,

Per our conversation and your email, attached you will find Utility Systems Science & Software (US3) response to your request. US3 is providing 1 sensor(s) for a period of 7 days.

This project will be monitored with the State of the Art Hach Flo-Dar Flow Meters.

- Review and provide input to the identified site,
- Validate site for suitability and traffic control,
- Calibrate and Install flow monitoring equipment,
- Validate preliminary data,
- Modify system to further support the monitoring requirements.
- Provide On-Site Training for Web-Based Viewing & Reporting of Sewer Monitoring Data.

Note: All data will be provided in a **Secure Web-Based Environment**.

Sincerely,

*Sheila Trisnojoyo*

Sheila Trisnojoyo  
Utility Systems Science & Software, Inc.

# Technical Approach

## Site Assessment

US3 will perform detailed site investigations/assessments of the potential monitoring site, assuring it is hydraulically suitable for accurate flow monitoring measurements. The site documentation shall include, at a minimum, a location map with address, digital photographs of the site, pipe size, channel condition, flow characteristics, site drawings, and pictures of surrounding area. The Site assessments will also identify traffic control and safety issues, and will be performed only by trained US3 staff.

## Equipment Installation, Site Maintenance, Equipment Removal

US3 staff will install all equipment in accordance manufacture recommendations and the associated Project Plan. Each sensor shall be calibrated by US3 before installation.

## Installation

In general, US3 will follow the Methods & Procedures (Attached) to install the Hach Sewer Flow Monitoring equipment. US3 will coordinate with the City prior to performing field work within the collection system, including confined space entry, traffic control as required.

## Site Maintenance

US3 staff will maintain all equipment, meeting reliability requirements. Where US3 guarantees 95% uptime or greater. General maintenance includes the recommended manufacturer maintenance procedures, field verifications, cleaning of sensors and diagnostics.

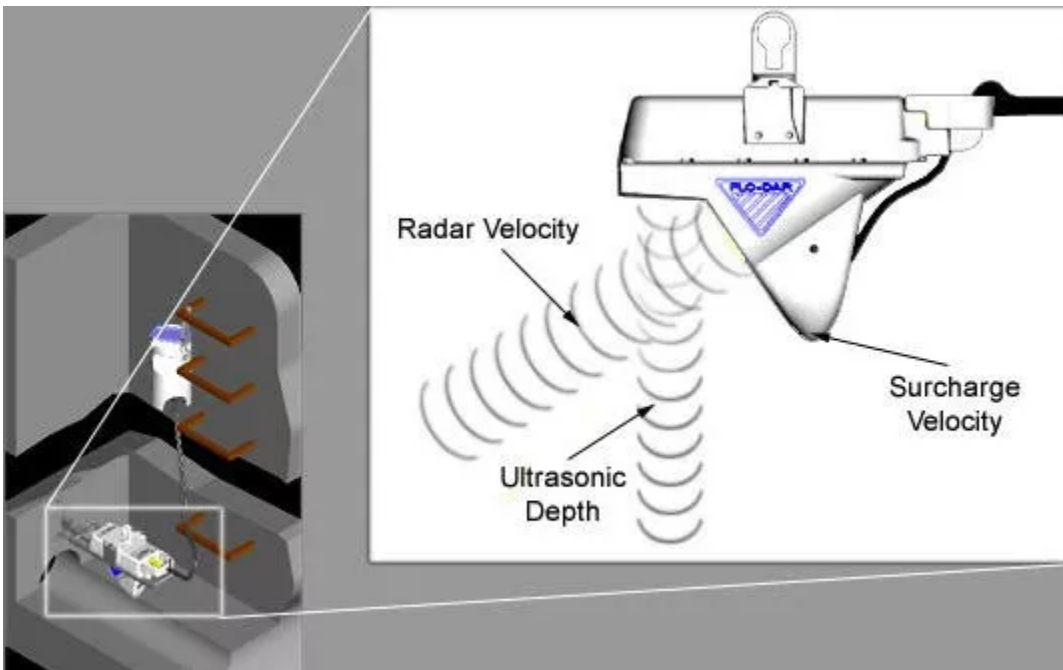

**Figure 1:** Flo-Dar - Flow Meter for Sewers & Open Channels

## Perfect solution for Difficult Flow Conditions:

- Flows with High Solids Content
- High Temperature Flows
- Caustic Flows
- Large Man-Made Channel
- High Velocities
- Shallow Flows



## Here's How It Works

Flo-Dar transmits a digital Doppler radar beam that interacts with the fluid and reflects back signals at a different frequency than that which was transmitted. These reflected signals are compared with the transmitted frequency. The resulting frequency shift provides an accurate measure of the velocity and the direction of the flow. Level is detected by ultrasonic pulse echo. Flow is then calculated based on the Continuity

Equation:

$Q = V \times A$ , Where  $Q = \text{Flow}$ ,  $V = \text{Average Velocity}$  and  $A = \text{Area}$ .

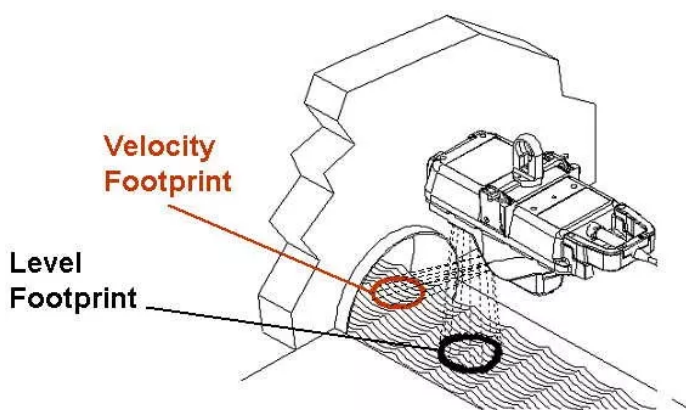

## Accurate Flow Measurements

Flo-Dar provides the user with highly accurate flow measurements under a wide range of flows and site conditions.

By measuring the velocity of the fluid from above, Flo-Dar eliminates accuracy problems inherent with submerged sensors including sensor disturbances, high solids content and distribution of reflectors.



# US3\_MH\_87942

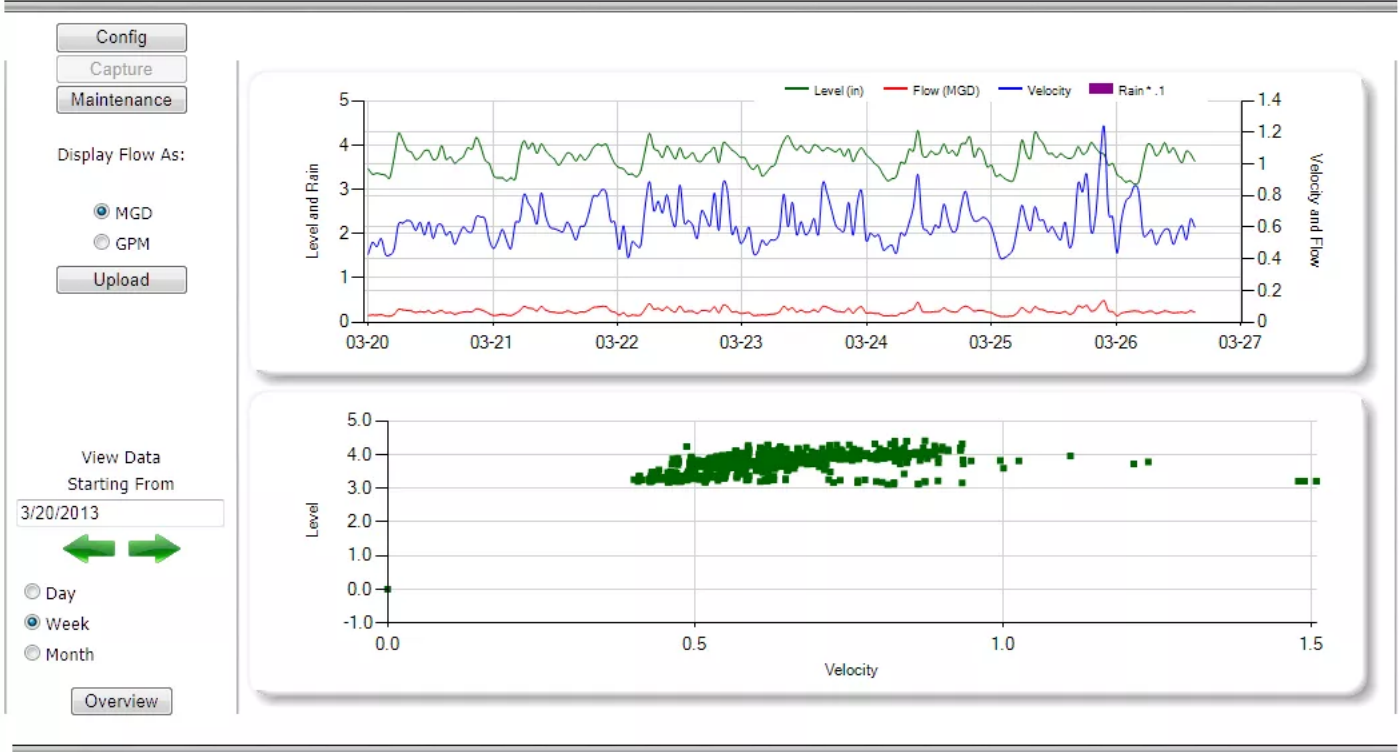

Figure 2: Standard Sewer Flow Monitoring Graph with the Scatter Plot.

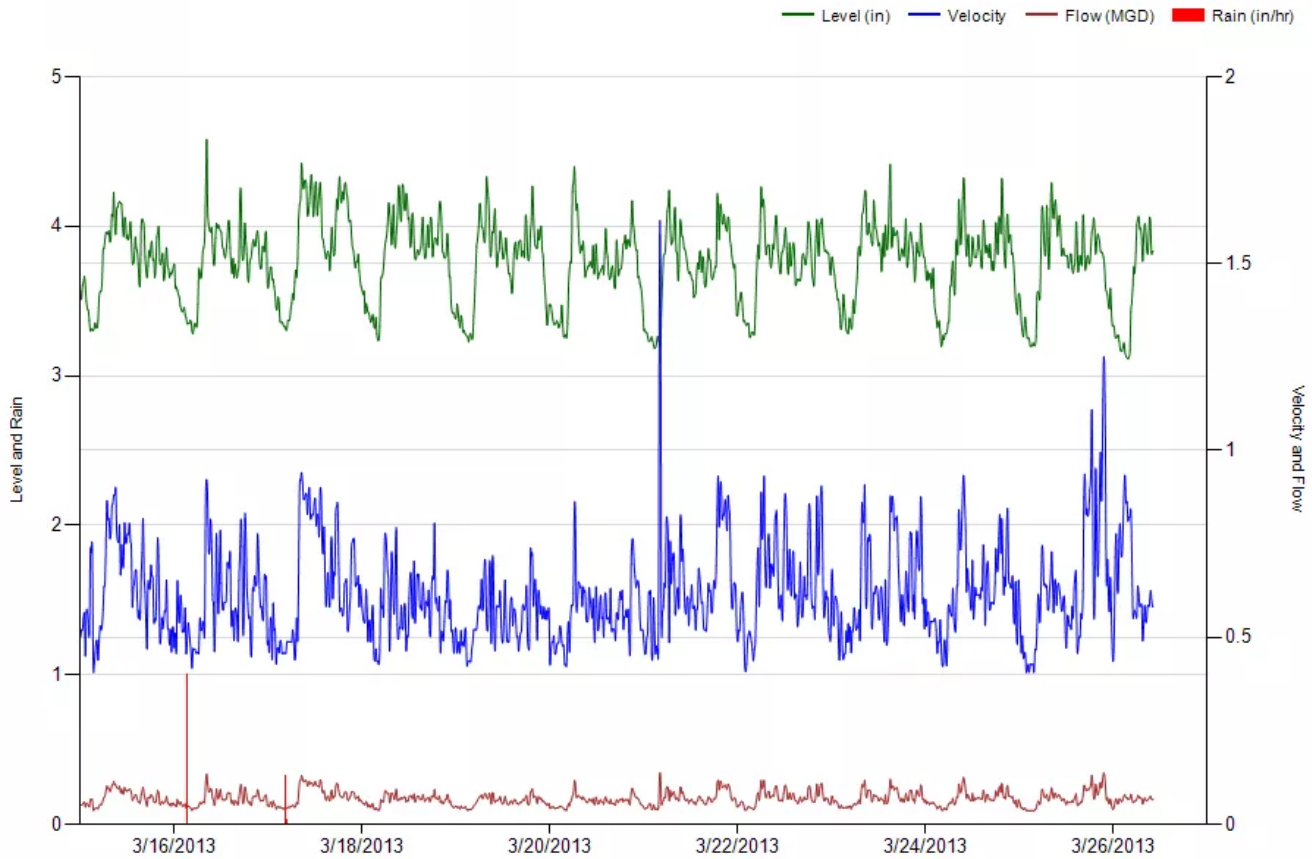

Figure 3: Expanded Graphs Report.

# Project Management & Staffing

---

The fundamental objective is to provide city with the high quality services by utilizing advance-metering technologies factory certified from Hach Co. All services will be completed per an agreed schedule. The Installations, Calibrations, Maintenance Services will be performed by US3 and Utility Systems Science and Software personnel and is designed to provide United with complete coverage with hardware, software and engineering. Thus, the Implementation Plan includes:

- Verify equipment installation/operation.
- Gather information as a prelude to software/hardware maintenance.
- Examine system following with the designed format forms.
- Provide engineering/technical on-site support as needed to support the system.
- Provide with 24 hrs on-call response support.

## Key Personnel

US3 possess all material, office and technical resources required to successfully maintain the system and provide skilled enhancements for United. Primary in support of this effort will be the following personnel:

- **Mark Serres** Vice President-Operations
- **Tom Williams** Engineering & Installation Manager
- **Darlene Szczublewski, P.E.**: Senior Civil Engineer

## Key Personnel Assigned

US3 possess all material, office and technical resources required to successfully monitor the system and provide skilled enhancements for United. With over 90 engineers and technicians, US3 can easily provide the necessary resources to fully implement this project. Primary in support of this effort will be the following personnel:

**Mr. Mark Serres:** Mr. Serres is a degreed electrical engineer with over 25 years systems Fresh/Waste water systems, project management and systems Integration experience in relation to complex industrial systems, this includes experience in industrial automation and water/waste water industries. Mr. Serres will be the primary point of contact for all technical issues for City. Mr. Serres will also be responsible for assuring client satisfaction and will marshal the required resources to meet the project requirements.

**Mr. Thomas Williams:** Mr. Williams will be the City Project Manager with over 15 years of complex systems development for wastewater monitoring system experience. This experience includes hydraulic compatibility, instrumentation, communications and analysis.

**Darlene Szczublewski, P.E.:** Mrs. Szczublewski has over ten years of engineering experience in flow monitoring related projects. She assisted in the review of flow meter data and the completion of several SSES and Capacity Analysis projects to meet Consent Decrees. Mrs. Szczublewski has completed numerous I/I-related studies for other clients as well. Mrs. Szczublewski has developed numerous flow data analysis techniques to present a clear informative picture of flow responses to storm events. Her work also includes the development of training programs for clients describing I/I and capacity analysis methodologies.



The Flo-Dar Family of flowmeters provide a revolutionary approach to open channel and sewer flow monitoring. Flo-Dar combines digital doppler radar velocity sensing technology with ultrasonic pulse echo level sensing to remotely measure open channel flows. Flo-Dar's unique non-contact measuring technology means trouble-free sewer flow monitoring. It even won the Water Environment Federation's Innovative Technology Award!

Like all Marsh-McBirney products, Flo-Dar sets the standard for ease-of-use, accuracy, and reliability. Flo-Dar accuracy has been independently confirmed by Alden Labs as well as the satisfaction of thousands of Flo-Dar users.



**Proposal #:** JIG\_051321

**Date:** May 13, 2021

Prepared for	Created by
Joseph Gutierrez Jig Consultants 318 West Katella Avenue, Orange, CA 92867 JGutierrez@jigconsultants.com (949) 396-2430	Sheila Trisnojoyo Utility Systems Science & Software, Inc. 601 N. Parkcenter Drive, Ste 209 Santa Ana, CA 92705 sheila.trisnojoyo@uscubed.com (714) 564-3494

## Proposal Cost

Description	Price	QTY	Subtotal
<b>Temporary Sewer Flow Monitoring - Rancho Santa Margarita</b>			
Sewer Flow Meter	\$950.00	1	\$950.00
Permit (not included)	\$0.00	1	\$0.00
Installation Materials	\$85.00	1	\$85.00
Flow Meter Installation	\$1,540.00	1	\$1,540.00
Removal Meter	\$840.00	1	\$840.00
			<b>\$3,415.00</b>

Subtotal	<b>\$3,415.00</b>
15% Discount on Installation	<b>-\$154.00</b>
<b>Total</b>	<b>\$3,261.00</b>

**Deposit Required: \$1,141.35**

**Notes:**

- Payment terms net 30 days
- Certified Installation & Calibration
- 95% Data Uptime Guarantee
- Secure Server
- Pre-packaged data in XLS, PDF and MS Word
- Maintenance & Repair Included
- Should extensive additional traffic control be required, it will be quoted separately.
- Permit may or may not be required. Should permit be required, it will be quoted separately.

# Sign here to approve

I hereby acknowledge I am authorized to enter into this contract and that I have read and approve this Proposal and understand and agree to the terms and conditions.

Joseph  
\_\_\_\_\_  
First Name

318 West Katella Avenue, Suite A  
Orange, CA 2867

Gutierrez  
\_\_\_\_\_  
Last Name

\_\_\_\_\_  
Billing Address

jgutierrez@jigconsultants.com  
\_\_\_\_\_  
Email

*Joseph Gutierrez*

05 / 17 / 2021

\_\_\_\_\_  
PO # (if applicable)

Signed by

Date of acceptance

## Payment terms & instruction

Payment terms net 30 days. Deposit/Mobilization fee is due after signature or the approval of the proposal.

### Pay by check

Company	Utility Systems, Science & Software, Inc.
Address	601 N. Parkcenter Dr, Ste 209, Santa Ana, CA 92705

### Pay by wire

Bank name	California Bank & Trust
Bank address	17752 E. 17th Street, Tustin, CA 92780
Wire ABA/Routing #	122232109
ACH Routing #	122003396
Swift Code	ZFNBUS55
Account name	Utility Systems, Science & Software, Inc.
Account address	601 N. Parkcenter Dr, Ste 209, Santa Ana, CA 92705
Account number	3210163671

If you have any question regarding the proposal please contact sheila.trisnojoyo@uscubed.com or mark.serres@uscubed.com, you can also call at 714-564-3494.

# Signature Certificate

Document Ref.: SDEEZ-4NHFN-VWAGA-EGSS2

Document signed by:

	<p><b>Joseph Gutierrez</b> E-mail: jgutierrez@jigconsultants.com Signed via link</p>	<p><i>Joseph Gutierrez</i></p> 
<p>IP: 23.241.236.121</p>	<p>Date: 17 May 2021 20:28:39 UTC</p>	

Document completed by all parties on:  
17 May 2021 20:28:39 UTC

Page 1 of 1



Signed with PandaDoc.com

PandaDoc is the document platform that boosts your company's revenue by accelerating the way it transacts.



**TRABUCO CANYON WATER DISTRICT  
REGULAR BOARD MEETING | JUNE 16, 2021**

**ACTION CALENDAR**

**ENGINEERING MATTERS**

**ITEM 14: DISCUSSION AND POSSIBLE ACTION(S) CONCERNING GOLF CLUB SEWER LIFT STATION IMPROVEMENTS**

---

Trabuco Canyon Water District (District) owns and operates the Golf Club Sewer Lift Station in the Dove Canyon community adjacent to the golf club driving range (Exhibit 1). This station receives wastewater flows from the majority of the community by way of Bell Canyon and Barneburg Sewer Lift Stations and gravity sewer flows, and then conveys the wastewater to the Robinson Ranch Wastewater Treatment Plant via a sewer force main on Hillrise. The station was constructed in the early 1990s and has undergone minor improvements since that time, but there are a series of critical repairs and improvements that Wastewater Operations and Maintenance Department (O/M) staff have identified for the station, some of which has been completed. The station will be fully evaluated during the upcoming condition assessment, and the anticipated improvements include a station Bypass Valve Assembly, Dry Pit and Wet Well Improvements and Piping/Valve Replacements.

The most critical item of concern is the Motor Control Center (MCC) Panel. Some of the components in the MCC Panel have been replaced due to failure, but there are many other system components that have reached the end of life. District staff has contracted with Hydrotech Electrical for much of this work to keep the station operating, but Hydrotech recommends an overhaul of the MCC Panel and many of the components due to low availability and technological advancement (Exhibit 2).

**FUNDING SOURCE:**

Emergency Reserves

**FISCAL IMPACT:**

\$308,000

**ENVIRONMENTAL COMPLIANCE:**

Notice of Exemption

**COMMITTEE STATUS:**

This matter was reviewed with the Engineering/Operational Committee.

**RECOMMENDED ACTION:**

*Authorize the General Manager to ratify a Contract with Hydrotech Electric for Golf Club Lift Station Motor Control Center Replacement in the amount of \$279,340 with a contingency of \$27,934, for a total not-to-exceed amount of \$307,274.*

**EXHIBIT(S):**

1. Project Site Map and Site Photos
2. Hydrotech Electric Proposal – Golf Club MCC Replacement

**CONTACTS (staff responsible): PALUDI/PEREA/LAUSTEN**



**Project Location**



**Location Map**

 Area of Work

**Golf Club Sewer Lift Station**

Address: 22881 Golf Club Drive      Trabuco  
Canyon CA 92679

# GOLF CLUB SEWER LIFT STATION REPAIRS & IMPROVEMENTS

Trabuco Canyon Water District  
June 2, 2021 E&O Committee





Motor Control Center

# Wet Well Condition



# Dry Pit-Surge Tank, Piping and Valves



**NOTES:**

1. CONTRACTOR TO CONSTRUCT 8" DUCTILE IRON PIPE TO MATCH SLOPE OF EXISTING FORCE MAIN.
2. CONTRACTOR TO CONSTRUCT 8" LINE STOP AND DRAIN CONTENTS OF ISOLATED FORCE MAIN PRIOR TO CONSTRUCTING BYPASS PIPING ASSEMBLY.
3. DUCTILE IRON PIPE SHALL BE CLASS 50 WALL THICKNESS WITH FUSION BONDED OR CERAMIC EPOXY LINING, 1 MIL ASPHALTIC COATING, ENCASED IN TWO LAYERS OF POLYETHYLENE BAGS.
4. ALL PLUG VALVES SHALL BE ECCENTRIC WITH 100% PORT SIZE.
5. ALL NUTS, BOLTS, AND FASTENERS SHALL BE TYPE 316 STAINLESS STEEL.

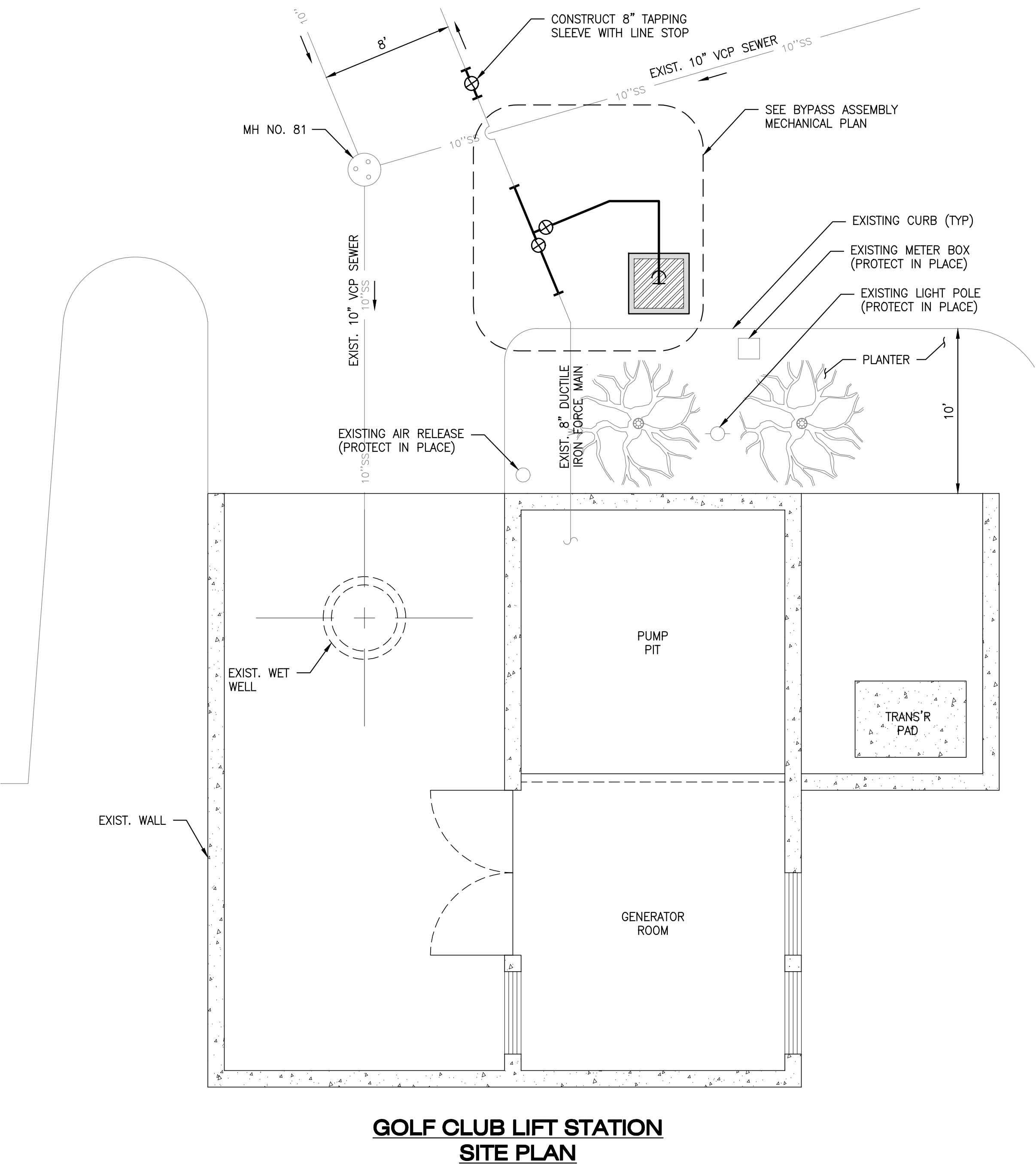

**GOLF CLUB LIFT STATION  
SITE PLAN**

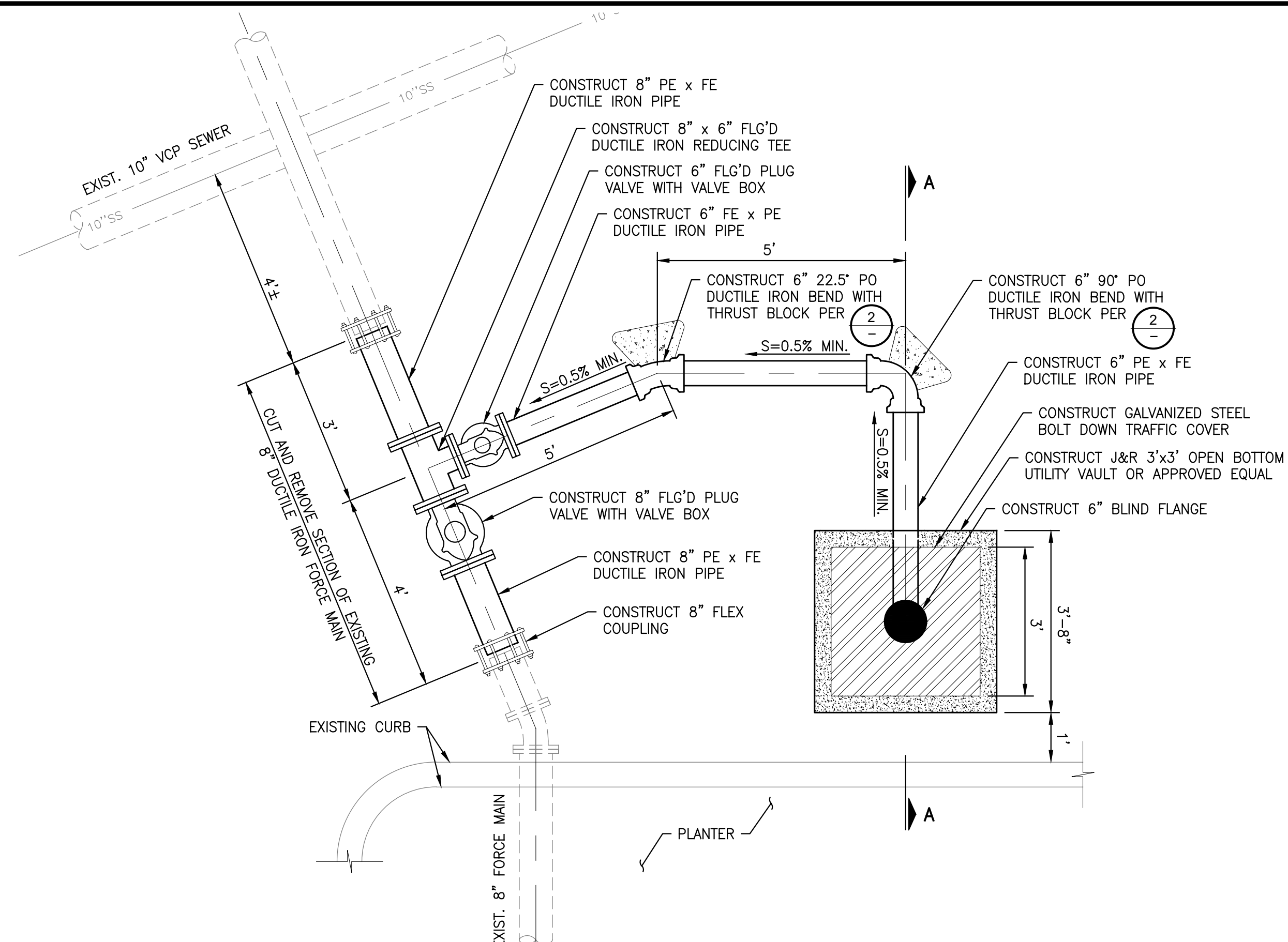
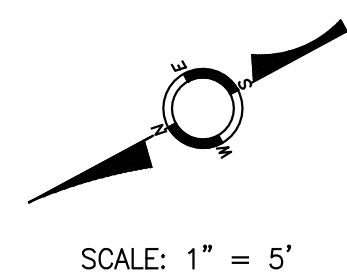

**BYPASS ASSEMBLY  
MECHANICAL PLAN**  
SCALE: 1/2"=1'-0"

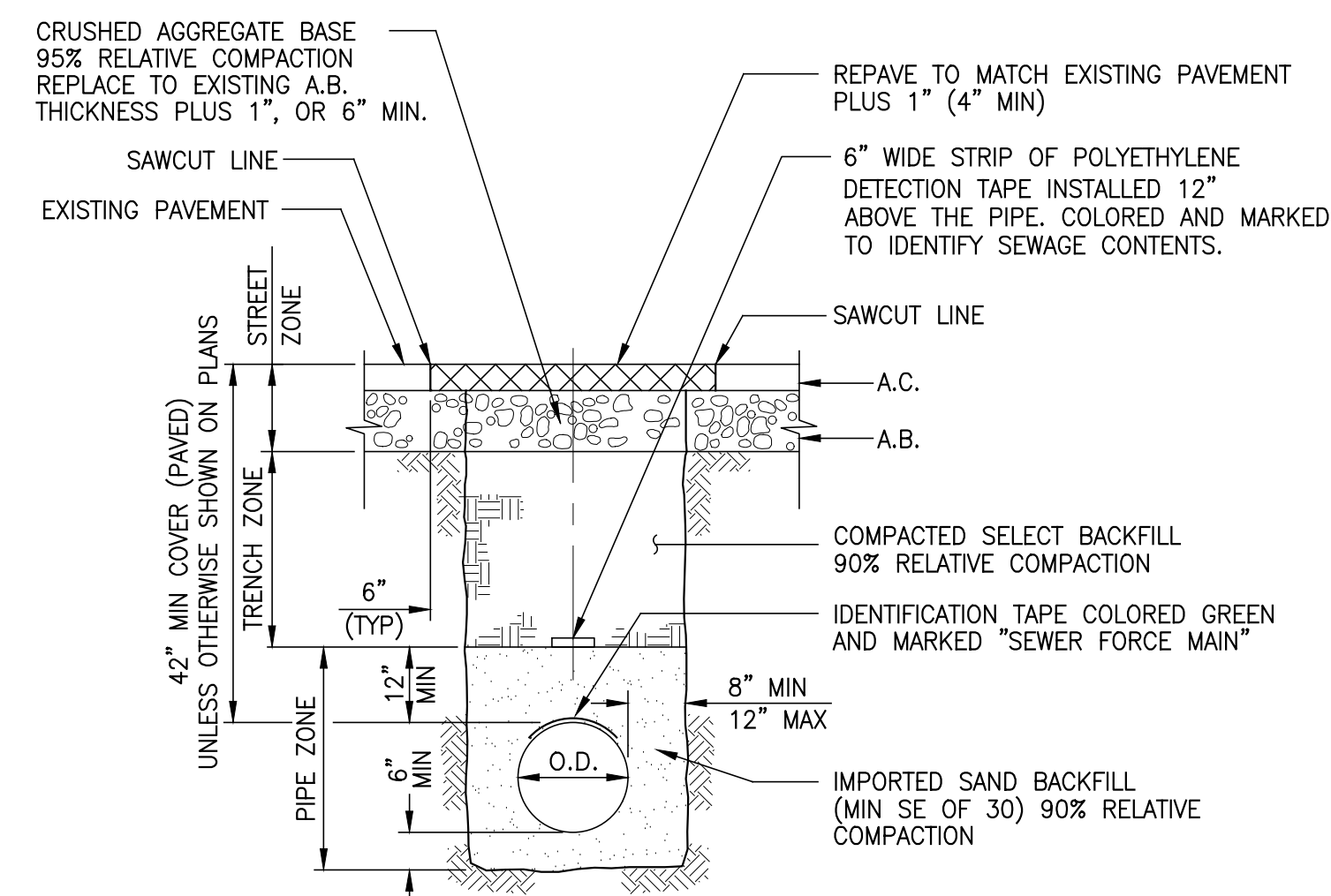

**NOTES:**

1. CONTRACTOR SHALL REPLACE AC TO THE LIMITS SHOWN ON THE TYPICAL TRENCH SECTION SHOWN ABOVE AND TO THE THICKNESS PLUS 1" OF THE EXISTING AC UNLESS OTHERWISE DIRECTED ON THE PLANS.
2. ALL PAVEMENT AND SIDEWALK REMOVAL NECESSARY FOR THE CONSTRUCTION OF THIS PROJECT SHALL BE SAWCUT PRIOR TO REMOVAL. THE OWNER SHALL BE REQUESTED BY CONTRACTOR TO APPROVE EXTENT OF PAVEMENT AND SIDEWALK REMOVAL PRIOR TO STARTING WORK. DISPOSAL OF REMOVED A.C. PAVEMENT AND CONCRETE SHALL BE AT AN APPROVED OFF-SITE DUMP SITE.

**TYPICAL TRENCH SECTION**  
NOT TO SCALE

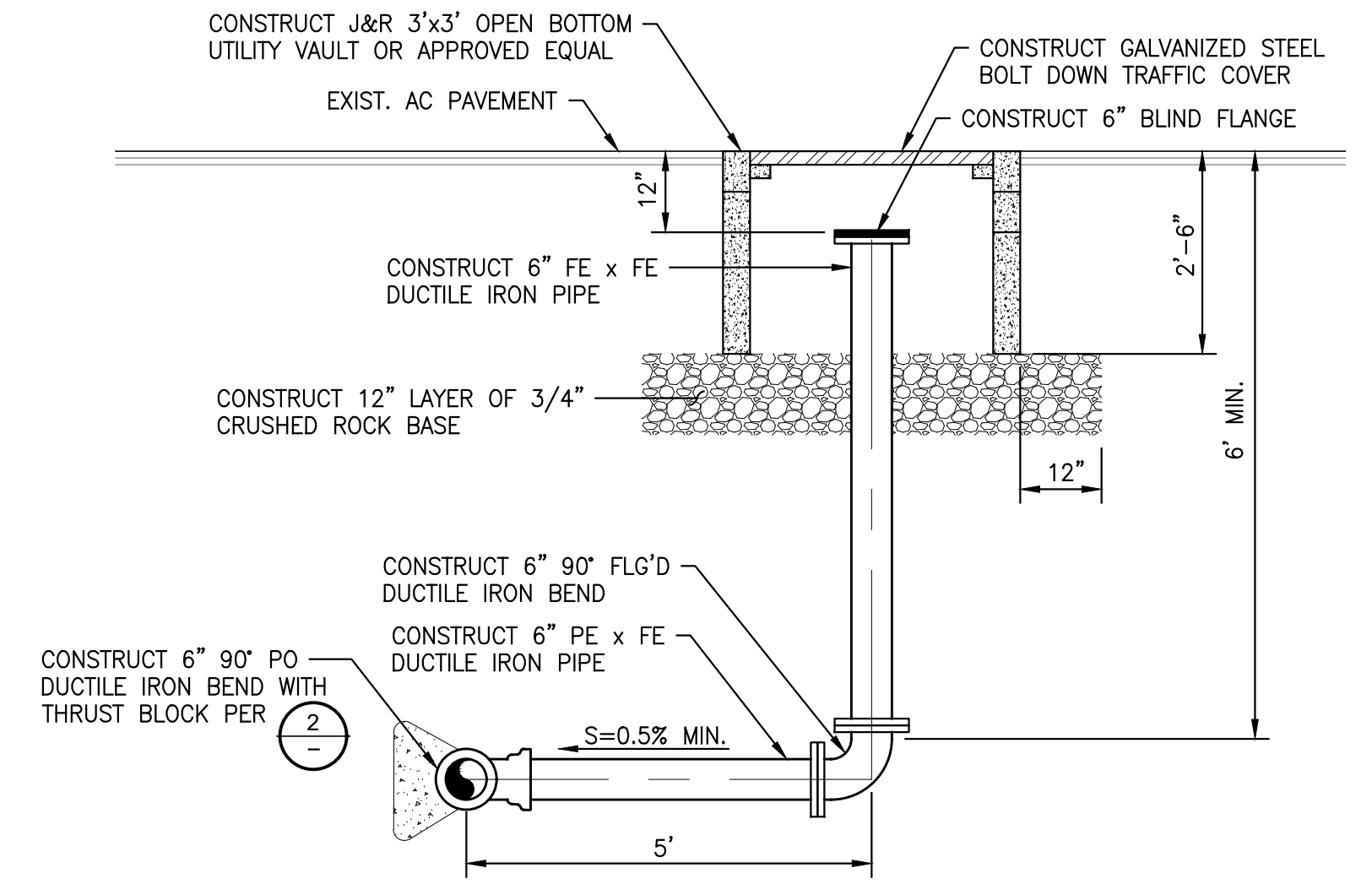

**SECTION A-A**  
SCALE: 1/2"=1'-0"

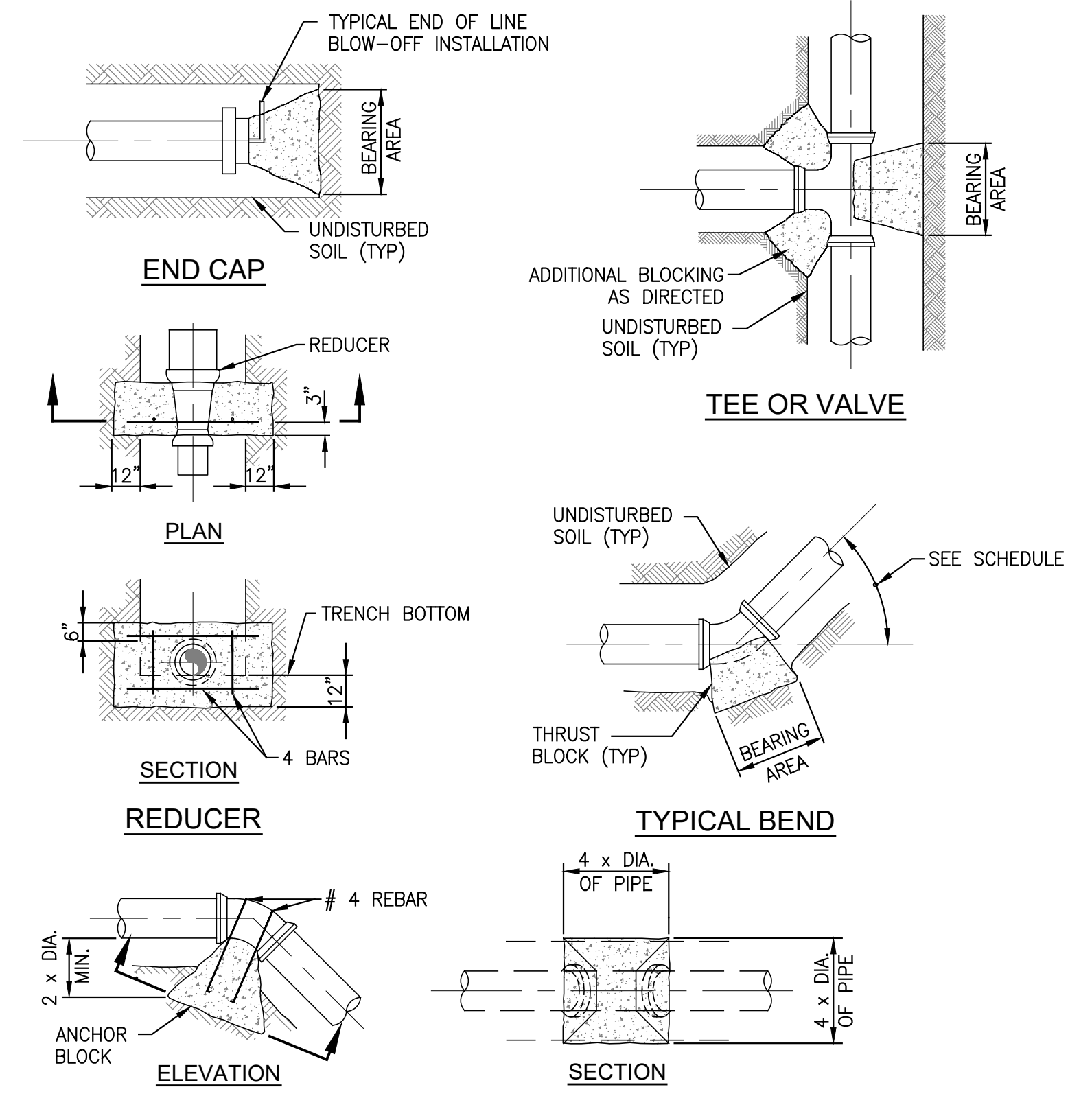

**VERTICAL BEND**

PIPE SIZE	MINIMUM THRUST BLOCK AND ANCHOR BLOCK SIZE				
	11 1/4" BEND	22 1/2" BEND	45" BEND	90" BEND	
	HORIZ. L <sub>1</sub> X L <sub>2</sub>	VERT. C.Y.	HORIZ. L <sub>1</sub> X L <sub>2</sub>	VERT. C.Y.	
6"	22" X 4"	0.04	22" X 8"	0.08	22" X 15"
				0.16	20" X 20"
				0.28	22" X 19"
					DEAD ENDS & TEES
					HORIZ. L <sub>1</sub> X L <sub>2</sub>
					VERT. C.Y.

**NOTES:**

1. THRUST BLOCK BEARING AREA BASED ON ALLOWABLE SOIL BEARING VALUE OF 1500 psf AND 150 psi LINE PRESSURE. FOR BEARING = 1000 psf, 1.5 x AREA SHOWN. FOR BEARING = 500 psf, 3.0 x AREA SHOWN.
2. ALL THRUST BLOCKS SHALL BE CLASS "B" CONCRETE AND PLACED AGAINST UNDISTURBED SOIL. DESIGN ENGINEER SHALL DETERMINE SIZES NOT SHOWN.
3. REINFORCING STEEL SHALL CONFORM TO ASTM A15 AND A305 INTERMEDIATE GRADE.
4. CONCRETE SHALL NOT EXTEND ONTO FLANGE OR ADJOINING PIPE.

**THRUST BLOCK**  
NOT TO SCALE

**DIGALERT** CALL TOLL FREE 811  
TWO WORKING DAYS BEFORE YOU DIG  
Underground Service Alert

CONTRACTOR SHALL NOTIFY UNDERGROUND SERVICE ALERT A MINIMUM OF 48 HOURS PRIOR TO BEGINNING ANY CONSTRUCTION WORK. SEE GENERAL NOTES FOR FURTHER INFORMATION.

**JIG CONSULTANTS**  
318 W KATELLA AVE, SUITE A  
ORANGE, CA 92867  
(714) 978-4407  
www.jigconsultants.com

REGISTERED PROFESSIONAL ENGINEER  
JOSEPH I. GUTIERREZ  
No. C 55604  
Exp. 12/31/22  
CIVIL  
STATE OF CALIFORNIA

NO.	DATE	REVISIONS

DESIGN: MM	DATE
DRAWN: MM	ENGINEER
CHECKED: JG	PRINCIPAL ENGINEER

TRABUCO CANYON WATER DISTRICT  
GOLF CLUB LIFT STATION BYPASS IMPROVEMENTS  
PROJECT NO. XXXX-XX

SITE PLAN / MECHANICAL PLAN AND SECTION



**PROPOSAL**  
TCWD  
GOLF CLUB LIFT STATION MCC REPLACEMENT

Addendum: None Noted

DIR REG # 1000001266

5-18-21 Pg 1 of 2

Specifications: TCWD Construction Standards

Proposal to furnish and install the following per plans and specs:

1. Selective electrical demolition including the removal and disposal of existing MCC.
2. Extension of existing concrete housekeeping pad as required to accommodate new MCC.
3. ***1- NEMA 12 400A 480V 3P3W Motor Control Center including:***
  - A) 1- 400A 480V Automatic Transfer Switch.
  - B) 1- 480V 400AT Main Circuit Breaker.
  - C) 1- Surge protection device and Phase Monitor Relay.
  - D) 4- 480V 125A MCP Circuit Breakers.
  - E) 4- 50HP Eaton S811+ RVSS Pump Starter Control Panel sections with all required appurtenances and controls.
  - F) 1- 15KVA 480-120/240V Transformer.
  - G) 1- 120/240V 1 phase 18 circuit panel.
  - H) 1- Surge Tank Control Panel with NEMA size 1 Starter including all required appurtenances and controls.
  - I) 1- Section for new PLC Panel.
4. Conduit, boxes, and wiring as required to install new Motor Control Center.
5. ***1- 100A 120/240V Temporary Power Panel for construction power connected to SCE Transformer.***
6. 2- NEMA 4X Stainless Steel 480V 100A Disconnects for submersible pumps.
7. 2- NEMA 4X Stainless Steel Sump Pump Termination Enclosures.
8. 2- New PVC Coated Rigid conduit, hubs, and explosion proof EYS seal offs for submersible pumps.
9. Grounding system as required by N.E.C.
10. ***Instrumentation and Controls Package including:***
  - A) ***1- Modicon M340 PLC Panel with all required I/O Modules including:***
    - B) 1- 1500VA UPS.
    - C) 1- 24V Power Supply.
    - D) 1- 8 Port Ethernet Switch
    - E) 2- Panel Fans with filtered louvers.
    - F) Panel condensation heater with T-stat.
    - G) Relays, indicator lights, terminal blocks, and all required appurtenances.
    - H) 2- 900 GHZ Radios and Yagi Antennas, cabling, and mounting as required.
    - I) 1- Magelis 10" Touch Screen HMI.
    - J) Incorporation of existing Bubbler System & Level Instrumentation.
    - K) ***PLC, HMI, and SCADA Programming as required for integration into SCADA system.***
    - L) 4- Wet Well Floats (LSHH, LSH, LSL, and LSLL).



**PROPOSAL**  
TCWD  
GOLF CLUB LIFT STATION MCC REPLACEMENT

PG 2 OF 2

11. Professional Services: Engineered shop drawings and submittals, control schematics, and As Built Drawings.
12. Start up & Commissioning, Field testing, configuration, calibration, and device signal spanning as required.
13. Onsite Training and O&M Manuals.

**Excluded from Scope:**

1. *Temporary Power Requirements for Lift Station pump operation or by-pass equipment.*
2. Building Permits, Utility charges, Bonds and Associated Fees.
3. Mechanical Equipment: Emergency Generator, Pumps, Exhaust Fans, Motorized gates, M.O.V.'s, Etc.
4. Any Instrumentation devices, Control Panels or Electrical panels not listed in the above scope of work

**Total Bid Price.....\$279,340.00**

**The removal and installation of the MCC will require a 10 working day shutdown of the Facility.**

**Lead time for fabrication of the MCC is 12-16 weeks.**

**Price Valid for 60 Days**

**If you have any questions or comments please call me,  
Sincerely,  
Ken Cloud.**

**37707 Green Knolls Road  
Winchester Ca. 92596  
909 948-1908**

**DIR# 100001266  
CLSB #977838  
WBE Certified**

**Ken Cloud 909 270-0430**

**TRABUCO CANYON WATER DISTRICT  
REGULAR BOARD MEETING | JUNE 16, 2021**

**ACTION CALENDAR  
ENGINEERING MATTERS**

**ITEM 15: PURCHASE OF A CUMMINS EMERGENCY PORTABLE 275KW DIESEL GENERATOR**

---

Trabuco Canyon Water District (District) faces the heightened threat of wildfires in and immediately adjacent to our service area and the new reality of Public Safety Power Shutoffs (PSPS) called by Southern California Edison during high wind events on a nearly year-round basis. Power interruptions or longer-term outages can severely impact water and sewer operations with customer service and regulatory consequences. Adequately sized trailer-mounted portable generators would help to mitigate this power outage risk, particularly for lift stations and other facilities that do not currently have on-site emergency backup power generators. The District currently owns a small trailer-mounted generator parked at the Administration Facility, however this generator is only adequate for running a portion of that building, primarily the IT servers.

District staff has researched various manufacturers and specifications in identifying a towable generator that can run every water and sewer lift station and yet be transported with District equipment. The District's larger facilities including the water treatment plant and wastewater treatment plant would require a generator too large to effectively transport. The unit that staff recommends is a portable trailer-mounted Cummins 275kw diesel generator, available from Duthie Power Services for \$173,981 including delivery, onsite startup, and sales tax (Exhibit 1). The District was awarded a grant earlier this year for \$99,750 from CalOES for community power resiliency which will be applied towards the generator purchase. The estimated delivery time is approximately 15-18 weeks. Furthermore, the ability to quickly connect the portable generator to a station will require improvements to most District lift stations by a combination of operations staff and electrical contractor services. District staff will prepare a scope and budget to retrofit the highest priority stations – primarily those without existing onsite backup power – during the delivery phase and seek separate approval for those services.

**FUNDING SOURCE:**

General Fund and CalOES Grant Funding (approximately 57%)

**FISCAL IMPACT:**

Equipment Purchase Price:	\$	173,981
Approximate 10% Contingency:	\$	16,019
CalOES Grant Funding:	\$	(99,750)
<b>Total Direct Fiscal Impact to the District:</b>	<b>\$</b>	<b>90,250</b>

**ENVIRONMENTAL COMPLIANCE:**

The emergency generator is emissions compliant (EPA Tier 4 Final Certified)

**COMMITTEE STATUS:**

This matter was reviewed with the Engineering/Operational Committee.

**RECOMMENDED ACTION:**

*Ratify the purchase of one Cummins Emergency Portable 275KW Diesel Generator for equipment for \$173,981 plus approximately 10% as contingency for a total not-to-exceed amount of \$190,000.*

**EXHIBIT(S):**

1. Duthie Power Services Quote

**CONTACTS (staff responsible): PALUDI/PEREA/LAUSTEN**



The Generator Experts • 24 Hour Service • License #708125

**Date: 4/27/2021**

**To:** Trabuco Canyon Water

**Attn:** Jason Stroud

**Reference: Emergency portable trailer mounted 275 kw Cummins Diesel generator.**

Thank you for your inquiry. We are pleased to offer the following quote for the above project

1. C275D2RE, Diesel Genset, 50/60 HZ, 275KW, Standby-Rental portable
  - a. U.S. EPA, Non road (Portable) Application
  - b. C275D2RE, Diesel Genset, 50/60 JZ. 275KW, Standby-Rental portable
  - c. Duty Rating – Prime Power (PRP)
  - d. Emissions-Compliance EPA Tier 4 Final Certified
  - e. Voltage 208 - 480 Variable
  - f. Alt-60Hz, 208/416-240/480 Volt, 125/80C (S/P)
  - g. Electric Brake Trailer
  - h. HITCH, PINTLE
  - i. UN31A Certified Fuel Tank
  - j. Generator Set Control - PowerCommand 3.3, Paralleling with MLD
  - k. Distribution Panel-Rental Bus Bar Connection
  - l. Packaging - Cummins Power Generation
  - m. Genset Warranty - Industrial Mobile Base, Prime 3 years / 3000 hours
  - n. Battery Charger - Rental
  - o. Engine Coolant - 60% Antifreeze, 40% Water mixture
  - p. Quick Fit Kit
  - q. Auxiliary DEF Connections
  - r. Paralleling Harness

<b>275 KW Genset:</b>	<b>\$158,767.20</b>
<b>Delivery to Site:</b>	<b>\$ 1,200.00</b>
<b>Onsite Start-up:</b>	<b><u>\$ 1,500.00</u></b>
<b>Total as listed</b>	<b>\$ 161,467.20</b>

**Notes**

**SALES TAX IS NOT INCLUDED**

**DIESEL FUEL NOT INCLUDED**

Estimated Delivery: **15-18 weeks** after the receipt of a purchase order and approved submittal

Prices valid for 90 days from above date

FOB: Jobsite. Offloading, craning, setting, anchoring is by others. All deliveries are Monday through Friday 7:00 a.m. to 4:00 p.m. Deliveries outside the normal business hours will be invoiced as necessary. Jobsite installation inspection, initial startup, and initiation of warranty, by a Duthie Power field technician is during normal working hours Monday through Friday 7:00 a.m. to 3:30 p.m. Testing will utilize building load unless the specification states otherwise. Fuel for testing is excluded. Any jobsite orientation and training of operating personnel to be done at the time of startup. Warranty is invalid without factory start



The Generator Experts • 24 Hour Service • License #708125

up. Additional charges will be applied to start ups requested on weekends or off normal business hours. The startup cannot be performed until all permits are secured.

**The above quotation is based off of verbal request only, no written specifications or drawings provided. This package may or may not fit the owner's application. Pricing subject to change. Only items listed on quotation are included. Exception is taken to anything that is not included in this proposal**

**The above quotation is for the sale of equipment only. Installation, wiring, permits, plan check, engineering, plumbing, concrete pad, DPF System and fuel are not included.**

Permit and license costs (Air Pollution/Quality, Fire, Building, etc.) are not included in this quote. Duthie Power does not assume any responsibility for obtaining any permits or licenses that may be required. Duthie is not responsible for informing the owner/buyer of any equipment requirements. *All permits must be obtained prior to installation of the equipment.*

#### **Acceptance of Quote**

Prior to ordering equipment or services, please sign and return as a confirmation of the below terms and conditions

#### **Terms and Conditions**

**Scope:** DUTHIE POWER SERVICES is pleased to offer the above quotation for your use on the referenced project.

**Delivery:** **Delivery is to the jobsite with offloading by others.** All efforts will be made to have all equipment at the jobsite with one delivery during normal weekday working hours of 7:00am to 4:00pm. Delivery or other services occurring at any other time is subject to additional charges. Special job conditions may dictate that one item or more may be needed prior to the balance of the equipment. In that event, payment for the item(s) shipped in advance is due and payable at time of advance shipment. Our invoice for the item(s) shipped in advance may include additional freight charges as a separate item of billing. The total of all invoices will be higher than the original proposal as additional freight costs will be incurred on split shipments.

**\*If delivery is to DUTHIE POWER SERVICES prior to the jobsite, the purchase terms may change and DUTHIE POWER SERVICES may charge a storage fee for any equipment stored over 30 days after arrival from the manufacturer.**

**Lead-times:** **Current lead time is 10-12 weeks after receipt of purchase order and approved submittals.** The Seller is not liable for any delay or failure to deliver any or all of the goods regardless of cause. Seller shall not be liable for incidental or consequential damages in the event of breach or repudiation of this agreement.

**Engineering:** All project or jobsite specific engineering is by others. DUTHIE POWER will assist in design or engineering by providing spec sheets and drawings only. Seismic Calculations are available (at additional costs) by others.

**Submittals:** Submittals will be provided within ten (10) working days from receipt of written purchase order.



The Generator Experts • 24 Hour Service • License #708125

**Permits:** It is the customer or end users responsibility to file and secure all permits, fees and licenses pertaining to the Air Quality Management District or the local ruling agency for the installation and operation of this equipment. All permits must be secured prior to installation.

DUTHIE POWER SERVICES assumes no responsibility for equipment ordered that does not comply with local codes or regulations.

Per SCAQMD Rule 1470, if the diesel generator is rated at or over 50HP and is placed within 100 meters of a K-12 school, a Particulate Trap (PM trap) is required. If the diesel generator is rated over 175HP and is within 50 meters of a sensitive receptor, it must meet the interim Tier 4 emission requirements. For natural gas and liquified propane gas generators, add-on emission control device applicability is based on currently effective Best Available Control Technology policy. For the other air districts outside of the South Coast Air Basin, the emission control requirement is determined on a case by case basis, predicated on the outcome of a site specific health risk assessment. A PM Filter or other add-on emission control device is not included in the above quote unless otherwise noted.

**Installation:** DUTHIE POWER SERVICES is a supplier of equipment and does not include installation, fuel, or piping whatsoever.

**Start-up Testing:** Upon completion of installation by others, a start and test will be performed by DUTHIE POWER SERVICES. It is strongly recommended that the start and test be performed within six months of delivery from the factory. If maintenance or service is required to bring the equipment up to new conditions as a result of the equipment being idle for more than six months, all maintenance, parts, labor and other associated costs will be the responsibility of the owner/buyer. The start and test will be performed during regular business hours, Monday thru Friday 7:00am to 3:30pm. (A start and test performed outside normal business hours will be an additional cost) **Fuel for testing is NOT included.** A building load test will be performed at no charge if it is performed at the time of the start and test. A load bank test with a resistive or reactive load bank is NOT included unless noted in the BOM. If the startup is not completed within 90 days of delivery, Duthie Power will require the job to be paid in full.

**Escalation:** Prices are firm for delivery for 30 days, subject to acceptance of our quotation.

**Venting:** Fuel tank venting as required on a local basis is **not** in our proposal, due to local practices and agencies. If details are available we may provide a quotation.

**Lugging:** Lugs on transfer switches, switchgear, and circuit breakers will be per manufacturer standard. No credit is allowed for unused lugs, unless we propose (in writing) to furnish special lugs at a price.

**Credit:** Credit is subject to DUTHIE POWER'S approval in its sole discretion. This quote in no way constitutes approval of credit.

**Terms/Invoicing:** Payment schedule is to be determined after acceptance of credit app and/or purchase order. If no further arrangements are made- the normal payment schedule is 40/30/20/10. 40% due at time of order; 30% due at time of delivery to Duthie Power Services; 20% due at time of delivery to job site; 10% due upon completion (startup). If equipment is at Duthie Power Services longer than two weeks after delivery the 20% will be billed. If equipment is delivered to jobsite- the normal payment schedule is 20/70/10. 20% due at time of order; 70% due at time of delivery to jobsite; 10% upon completion (startup). Seller reserves the right to require accelerated payment terms including cash payment in full advance of ordering any product or material.

**LOCAL CODE REQUIRED FUEL TANK FEATURES:** Increasingly, local fire code enforcement entities are requiring fuel tank options over and above that which is required by National Fire Protection Association (NFPA) or

California Fire Code (CFC), such as fuel fill spill containment basins and automatic fuel fill shut-off solenoids. Other requirements may apply to your specific project. We recommend that you contact the fire



The Generator Experts • 24 Hour Service • License #708125

enforcement entity, having jurisdiction over your project, to determine their specific requirements. *This quote excludes these options unless otherwise noted.*

**Taxes are not included in any quotes given unless otherwise noted.** DUTHIE POWER is a supplier of equipment, not a subcontractor, and as such, does not allow or accept retentions.

- If required by buyer, 3<sup>rd</sup> party Insurance Verification (i.e. Compliance Depot) and vendor registration fees are additional.

**Cancellations:** Circumstances may require cancellation of some or all of equipment ordered. In that event, cancellation charges will be levied based on actual decisions and costs imposed by manufacturer.

**Liens and others:** We follow all state and federal laws. Company policy requires that we file preliminary notices. We will also file stop notices or the prerequisite notice on payment bonds if payment for items purchased is not paid according to the terms or before the expiration of time allowed by California Civil Code. This proposal is subject to the terms and conditions stated herein and on the attached page

**Indemnification Clause:** Customer is aware that DUTHIE POWER SERVICES will provide the equipment based on customer's specifications. Equipment provided will be purchased from the manufacturer identified in DUTHIE POWER SERVICES' quote and/or customer's purchase order. DUTHIE POWER will transfer to customer the standard warranty policy offered by the manufacturer, and it will not be responsible for product alteration, misuse, abuse by customer, or late delivery due to manufacturer lead time. Customer shall indemnify, defend, and hold harmless DUTHIE POWER SERVICES from any and all claims, demands, costs, expenses, liabilities, damages, injury or death of any person directly or indirectly arising out of or related to this purchase of equipment from DUTHIE POWER; provided, however, that no Indemnified Party shall be entitled to indemnification for any Claim found by a court of competent jurisdiction to have been caused by the sole negligence or willful misconduct of such Indemnified Party.

**ATTORNEY'S FEES:** If either parties to this Agreement should bring suit against the other with respect to this Agreement, then all costs and expenses incurred by the prevailing party therein shall be paid by the other party.

**Acceptance:** Purchase order for order implies acceptance of above terms and conditions unless otherwise stated on purchase order. This quote MUST also be signed below before a purchase order can be accepted.

**By signing below you are agreeing to the above quotation and terms:**

**Mike Goodman**  
**mikeg@duthiepower.com**  
**Sales Engineer**  
**Duthie Power Services**  
**562-790-1772**

**Accepted By:**  
**Company Name**  
**Purchaser**  
**Signature**

**Date**

**PO#**

**TRABUCO CANYON WATER DISTRICT  
REGULAR BOARD MEETING | JUNE 16, 2021**

**ACTION CALENDAR**

**ENGINEERING MATTERS**

**ITEM 16: PURCHASE APPROVAL OF A TRAILER MOUNTED EMERGENCY BYPASS PUMP FOR WASTEWATER OPERATIONS**

Trabuco Canyon Water District owns and operates the Robinson Ranch Wastewater Treatment Plant (WWTP) and seven sewer lift stations to provide wastewater services to its customers in its service area. The operation of these facilities includes periodic decommission for upgrades and repairs, including, but not limited to, wet well, equalization basin, and tank cleaning and/or recoating, pump repair and/or replacement, and temporary station bypass for general facility maintenance and improvements. In order to accomplish these types of regular tasks, District Operations and Maintenance Department staff have rented trailer-mounted emergency transfer pumps over the years and have determined that the purchase of this piece of equipment would be a more cost effective and efficient use of public funds as opposed to the continual payment of rental fees.

As part of the Fiscal Year 2020/2021 Capital Improvement Plan, the Board of Directors approved a budget of \$110,000 for the purchase of an Emergency Bypass Pump to meet this need. District staff has procured two quotes from qualified vendors for one trailer-mounted emergency transfer pump as follows:

<b>Vendor</b>	<b>Model</b>	<b>Proposal Cost</b>	<b>Procurement Timeline</b>
Rain for Rent	HH125c High Head Pump	\$89,989	16 – 20 Weeks
Xylem Dewatering Solutions	Dri-Prime NC150 Custom 6” Pump	\$83,690	16 – 20 Weeks

District staff recommends the purchase of the Dri-Prime NC150 Custom 6” Pump from Xylem Dewatering Solutions for \$83,690 plus a 10% contingency to cover additional costs for pump hoses and fittings for a total not to exceed amount of \$92,360.

**FUNDING SOURCE:**

General Fund.

**FISCAL IMPACT**

\$83,690 plus a 10% contingency for a total not to exceed amount of \$92,360

**ENVIRONMENTAL IMPACT**

Not applicable

**COMMITTEE STATUS**

This matter was reviewed with the Finance/Audit Committee

**RECOMMENDED ACTION**

*Approve the purchase of one Godwin NC150 Dri-Prime Pump from Xylem Dewatering Solutions for \$83,700 plus approximately 10% as contingency for a total not-to-exceed amount of \$92,070.*

**EXHIBITS**

1. Emergency Bypass Pump Quotes

**CONTACTS (staff responsible): PALUDI/PEREA/LAUSTEN**

**SALE QUOTATION**

ITEM	QTY	DESCRIPTION	UNIT PRICE	SALE TOTAL
A	1	Dri-Prime NC150S Critically <ul style="list-style-type: none"> <li>• Silenced Sound Attenuated Enclosure</li> <li>• 6" 150# Flange Suction and Discharge</li> <li>• Isuzu 4LE2X FT4 Diesel Engine with FST</li> <li>• Global Series 6 Skid-mounted</li> <li>• Spill Containment, 110% Fuel Containment</li> </ul>	\$ 54,723.00	\$ 54,723.00
B	1	CD150M GL7 W/Bskt&HR for CS Encl (8299)	10,315.00	10,315.00
C	1	(2) 12/24V LED Work Lights w/Switch	578.00	578.00
D	1	PrimeGuard Float Set <ul style="list-style-type: none"> <li>• w/ 65' Mechanical Floats</li> </ul>	412.25	412.25
E	1	Battery Charger - 12 Volt Trickle	385.05	385.05
F	1	6" Male QD x 150# Flange <ul style="list-style-type: none"> <li>• Mounting Kit includes Adapter,</li> <li>• Flange Gasket, Bolts &amp; Nuts</li> </ul>	391.00	391.00
G	2	6" Female QD x 150# Flange <ul style="list-style-type: none"> <li>• Mounting Kit includes Adapter,</li> <li>• Flange Gasket, Bolts &amp; Nuts</li> </ul>	267.75	535.50
H	1	6" Female Godwin QD x 4" Male Godwin QD Adapter	165.75	165.75
I	5	6" x 10' Black Water Suction Hose with Godwin QD Fittings	360.80	1,804.00
J	4	6" 90 Degree Godwin QD Bend	298.40	1,193.60
K	5	6" X 10' Composite Hose with 150# Flange Fittings	783.00	3,915.00

**Please note all sale pricing is in U.S. Dollars. The price does not include freight, export boxing, duties, taxes, or any other items not specifically mentioned.**

This pricing information is for internal use only. We ask that these items and terms be kept confidential. All applicable tax and freight charges will be added to invoices. All quotations are subject to credit approval. All quotations are valid for 30 days. All prices quoted in US dollars.

This order is subject to the Standard Terms and Conditions of Sale - Xylem Americas effective on the date the order is accepted which terms are available at <https://www.xylem.com/en-US/support/xylem-americas-standard-terms-and-conditions/> and incorporated herein by reference and made a part of the agreement between the parties.

**SALE QUOTATION**

ITEM	QTY	DESCRIPTION	UNIT PRICE	SALE TOTAL
L	1	Delivery Motor Freight Br 017	3,250.00	3,250.00

**Our current delivery lead-times associated with this Quotation are best estimates at this time. Due to the outbreak of the COVID-19 virus pandemic and its global effects on commerce, supply chain, and logistics, these lead-times are an estimate only and not a commitment. Xylem is and will continue to use all commercially reasonable efforts to minimize any delivery delay impacts.**

**NET SALE TOTAL**

**\$ 77,668.15**

TAX

\$6,019.28

Grand Total

**\$83,687.43**

**Please note all sale pricing is in U.S. Dollars. The price does not include freight, export boxing, duties, taxes, or any other items not specifically mentioned.**

This pricing information is for internal use only. We ask that these items and terms be kept confidential. All applicable tax and freight charges will be added to invoices. All quotations are subject to credit approval. All quotations are valid for 30 days. All prices quoted in US dollars.

## Performance Curve

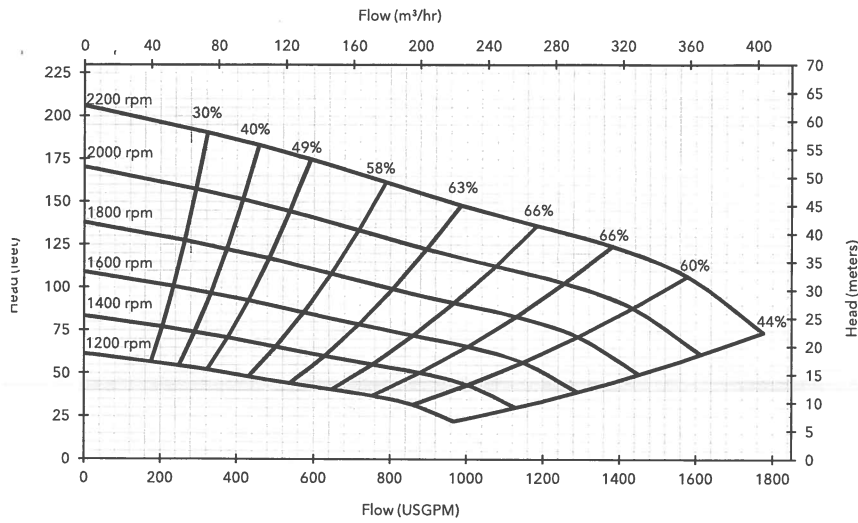

### Engine option 1

John Deere, 4045TF290 (IT4 Flex), 75 HP @ 2200 rpm

Impeller diameter 11"

Pump speed 2200 rpm

#### Suction Lift Table

Total Suction Head (feet)	Total Delivery Head (feet)				
	2164	5115	65151	72167	80187
	Output (USGPM)				
10	1574	1211	581	363	48
15	1308	1114	533	242	-
20	1090	969	339	-	-
25	848	678	242	-	-

Fuel capacity: 60 US Gal

Max Fuel consumption @ 2200 rpm: 4.4 US Gal/hr

Max Fuel consumption @ 1800 rpm: 3.8 US Gal/hr

Weight (Dry): 3,080 lbs

Weight (Wet): 3,500 lbs

Dimensions: (L) 119" x (W) 66" x (H) 77"

Performance data provided in tables is based on water tests at sea level and 20°C ambient. All information is approximate and for general guidance only. Please contact the factory or office for further details.

## Materials

Pump casing & suction cover	Cast iron BS1561:1997
Wearplates	Front - Hard Iron EN12513:2000 Rear - Cast Iron BS1561:1997 0
Pump Shaft	Carbon steel BS970:1991 817M40T
Impeller	Hard Iron EN12513:2000
Non-return Valve body	Cast iron BS1561:1997
Mechanical Seal	Silicon carbide face; Viton elastomers; Stainless steel body

### Engine option 2

Caterpillar, C4.4M-T (Export Only), 78 HP @ 2200 rpm

Impeller diameter 11"

Pump speed 2200 rpm

#### Suction Lift Table

Total Suction Head (feet)	Total Delivery Head (feet)				
	3066	50117	66153	73169	82189
	Output (USGPM)				
10	1574	1211	581	363	48
15	1308	1114	533	242	-
20	1090	969	339	-	-
25	848	678	242	-	-

Fuel capacity: 60 US Gal

Max Fuel consumption @ 2200 rpm: 4.6 US Gal/hr

Max Fuel consumption @ 1800 rpm: 4.2 US Gal/hr

Weight (Dry): 3,080 lbs

Weight (Wet): 3,500 lbs

Dimensions: (L) 119" x (W) 66" x (H) 77"

Performance data provided in tables is based on water tests at sea level and 20°C ambient. All information is approximate and for general guidance only. Please contact the factory or office for further details.

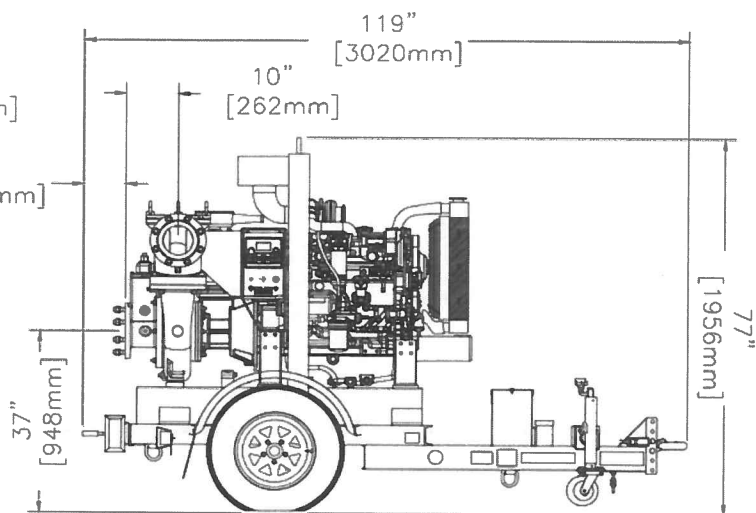
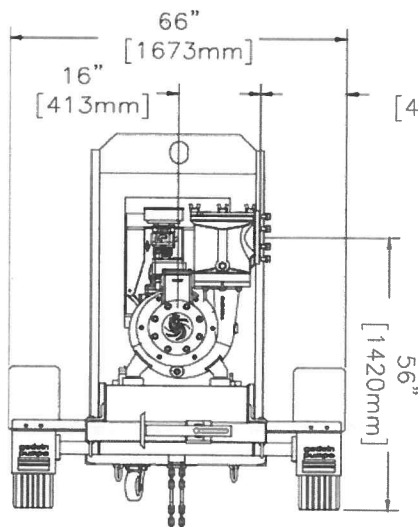

**xylem**  
Let's Solve Water

84 Floodgate Road  
Bridgeport, NJ 08014 USA  
(856) 467-3636 . Fax (856) 467-4841  
Email: sales@godwinpumps.com

Reference number : 95-1805-3000  
Date of issue : February 26, 2014  
Issue : 8

[www.godwinpumps.com](http://www.godwinpumps.com)



Sale Quotation

Long Beach

www.rainforrent.com

1301 East Spring Street
Long Beach CA 90806
Phone: 562-595-7760
Fax: 562-595-7357

Quotation Number: 1030-IND-954449

Prepared By: Spencer Wolfe

Job Description:

Sale of (1) PPP MDL 4414T-PP-4045HFC06-T180-SA trailer mounted, end suction centrifugal, vacuum assisted pump. FOB Long Beach 90806. Customer to sign off on Pump performance curve and spec sheet prior to order acceptance.

Customer: TRABUCO CANYON WATER DISTRICT

Customer ID: 104035
Address: 32003 DOVE CANYON DRIVE
City/State: TRABUCO CANYON, CA 92679
Contact: Jason Stroud
Office:
Fax:

Location:

Delivered to: Rain for Rent, 1301 E. Spring Street, Long Beach, CA 90806.

Sale Sub Total: \$89,933.84

Sub Total: \$89,933.84

Recommended Optional Items - Rental: \$0.00
Recommended Optional Items - Sales: \$0.00
Does not include sales tax

Accept/Decline:
Initial:

By checking Accept and initialing customer is acknowledging that the additional cost for the above items will be added to the grand total.

Rental Protection - RPP: \$0.00

Table with 2 columns: Item Name, Amount. Includes Est. Delivery Hauling, Est. Pick-up Hauling, Est. Install Labor, Est. Removal Labor, Est. Services, Est. Air Quality Fee, Est. Rev Air Quality Fee, Est. Enviro Recovery Fee, Est. Rev Enviro Recovery Fee.

( Does Not Include Sales Tax )

Grand Total: \$89,988.84

Date Prepared: 4/26/2021

Valid Until: 5/26/2021

Customer

Date

By signing this quotation, customer represents that he/she has read and agreed to both the Statement of Work and Scope of Agreement sections, and is also agreeing to the grand total amount listed above, plus any recommended optional items if checked and initialed. If customer requires a Purchase Order number to process and submit payment, it must be supplied to Rain for Rent at the time of acceptance of this quotation. Please insert Purchase Order number here:

Rental Protection Plan

I have received and reviewed the Rental Protection Plan Agreement incorporated as the last page of this estimate. By initialing this paragraph, I understand that I am agreeing to enter into and be bound by the terms of the Rental Protection Plan Program Agreement and that I am authorized to enter into this Agreement on behalf of Customer. FOR ALL RENTALS OF EQUIPMENT, EXCEPT THOSE SPECIFICALLY EXCLUDED, YOU MAY EITHER SHOW PROOF OF PROPERTY INSURANCE IN ACCORDANCE WITH INSURANCE REQUIREMENTS AND RENTAL AGREEMENT, OR PURCHASE THE RENTAL PROTECTION. THE PURCHASE OF THE RENTAL PROTECTION PLAN FOR RENTALS OF EQUIPMENT IS NOT MANDATORY AND MAY BE DECLINED IF YOU HAVE PROOF OF ALL RISK PROPERTY INSURANCE AS REQUIRED BY CONTRACT.

Initial here:



# Sale Quotation

Long Beach

www.rainforrent.com

1301 East Spring Street  
Long Beach CA 90806  
Phone: 562-595-7760  
Fax: 562-595-7357

Quotation Number: 1030-IND-954449

Application: Pump Sale Materials: NA Flow: See Pump Curve Suction Lift: NA Friction Loss: NA

Static Head: NA

This quotation has not been flagged as PREVAILING WAGE.

## Sale Items

Qty	Unit	Item	Description	Unit Price	Extension
1	Each	M240	PPP HH-125C Pump, Mdl 4414T-PP-4045HFC06-T180-SA	\$80,866.67	\$80,866.67
1	Each	M240	Est. Sales Taxes @ 7.75%	\$6,267.17	\$6,267.17
1	Each	M240	Estimated Transportation to RFR Long Beach from Premier Pump	\$2,800.00	\$2,800.00

Sale Sub Total: \$89,933.84

Sub Total: \$89,933.84



## Sale Quotation

Long Beach

www.rainforrent.com

1301 East Spring Street  
Long Beach CA 90806  
Phone: 562-595-7760  
Fax: 562-595-7357

Quotation Number: 1030-IND-954449

### Statement of Work

#### **Background:**

Customer has requested a sale price for (1) 4" centrifugal High-Head Sound-Attenuated Diesel Pump as described below. Pricing is good for 30 days from the date of this estimate. Inbound freight charges are subject to revision at any time.

#### **Scope:**

Sale of the following:

PPP model 4414T-PP-4045HFC06-T180-SA, trailer mounted, end suction centrifugal, vacuum assisted sound attenuated pump. Unit consists of 50 CFM vacuum pump, heavy duty flapper-type check valve, Tungsten vs. Silicon Carbide seal with run dry feature.

Pump Construction - All Iron

6" suction, 4" discharge.

14" impeller diameter with 3" solids handling capabilities.

Engine - Tier 4 Final John Deere model 4045HFC06 rated at 173 HP @ 2400 RPM.

Panel - Controls Inc. w/ autostart.

Frame - Galvanized steel trailer, 180 gallon fuel capacity, with lifting frame. Dual axle, fenders, jack stands, DOT lights, electric brakes.

**NOTE: Applicable taxes of 7.75 % are shown in the quote as a line item.**

NOTE: Freight is FOB Rain for Rent, 1301 E. Spring Street, Long Beach, CA 90806. Freight is subject to change. Quoted as a partial load and may take up to ten days after manufacture for delivery.

NOTE: All sales are final. Warranty is that provided by the manufacturer.

#### **References Materials:**

Customer is required to sign off on the Pump specification sheet and performance curve prior to order acceptance. Order is subject to approved credit, and a deposit may be required prior to formal order entry. PPP warranty and warranty procedure to be provided via separate email attachment.

LEAD TIME: 16-20 WEEKS ARO.

DMV TRAILER REGISTRATION IS TO BE PERFORMED BY BUYER. RAIN FOR RENT WILL PROVIDE A "CERTIFICATE OF ORIGIN" TO CUSTOMER FOR REGISTRATION PURPOSES.

#### **Operating Parameters:**

Pump performance curve provided via email attachment.

#### **Rain for Rent Responsibilities:**

Rain for Rent will provide the Pump specified herein on a final sale basis. Applicable taxes are included. Pump is quoted FOB Rain for Rent Long Beach, 1301 E. Spring Street, Long Beach, CA 90806



## Sale Quotation

Long Beach

[www.rainforrent.com](http://www.rainforrent.com)

1301 East Spring Street  
Long Beach CA 90806  
Phone: 562-595-7760  
Fax: 562-595-7357

---

Quotation Number: 1030-IND-954449

**Customer Responsibilities:**

- DMV trailer registration.
- Will Call from the Rain for Rent Long Beach yard.

**Rain for Rent Exclusions:**

- Delivery beyond the Rain for Rent Long Beach Branch location.



## Sale Quotation

Long Beach

www.rainforrent.com

1301 East Spring Street  
Long Beach CA 90806  
Phone: 562-595-7760  
Fax: 562-595-7357

Quotation Number: 1030-IND-954449

### Scope of Agreement

If Customer has entered into a Master Service Agreement with Rain for Rent and there is a conflict between the terms and conditions of this Scope of Agreement and the Customer's Master Service Agreement, then the terms and conditions in the Customer's Master Service Agreement signed by Rain for Rent will prevail.

Availability of products and services is subject to change without notice.

The rental period begins the day the equipment is delivered and continues until returned to originating Rain for Rent facility unless agreed to in writing before the rental period begins. A Cycle is defined as 4 weeks or 28 days which is our standard billing period. The weekly and/or daily rate for equipment quoted will be listed in the products grid when products are eligible for less than cycle rates. Payment terms are net 30 days from invoice date. Interest at the rate of 18% per year shall be charged on any past due invoice.

A Fuel Surcharge will be calculated and invoiced based on the diesel fuel price as published by the Department of Energy on <https://www.eia.gov/petroleum/gasdiesel>

An Environmental Recovery Fee shall apply to all rental charges invoiced for the duration of the rental pursuant to this quote/Estimate to help offset direct and indirect costs associated with regulatory compliance, obtaining permits, and obtaining licenses. California Air Quality Fee will be added to the cost of diesel pumps used in California only. This is a State mandated fee.

Customer is prohibited from deducting retention from Rain for Rent invoices and charging Rain for Rent liquidated damages.

Customer is responsible for flushing and cleaning tanks, roll off boxes, pipelines, pumps, filters and other Rain for Rent equipment prior to return unless specifically agreed to by both parties in writing.

The Terms and Conditions of the Rain For Rent Rental and Acute Hazardous Waste Agreements, Credit Application/Master Rental & Sales Agreement, Invoice and this Quotation (also known as the Rain for Rent Rental/Sale Estimate as may be referenced in any Master Service Agreement, Blanket Purchase Order, or any other contractual document executed between the parties) contain the complete and final agreement between Rain For Rent and Customer and no other agreement in any way modifying or adding to any of said Terms and Conditions will be binding upon Rain For Rent unless made in writing and signed by a Rain For Rent Corporate Officer or Rain for Rent authorized representative.

The Customer cannot alter the equipment without Rain for Rent's prior written approval. Customer is responsible for equipment, repairs, maintenance and damage, excluding normal wear and tear or damage caused by Rain for Rent. All returned equipment is subject to inspection by Rain for Rent personnel. Damages and accrued rent will be invoiced to Customer while equipment is out of service for repairs. The Customer is responsible for damage caused by reactive, corrosive or abrasive material; including, but not limited to sand, sodium hydroxide, chlorine, and acids. Customer must notify Rain for Rent immediately of any spill so that any necessary repairs to the system can be made and to minimize service interruption. The Customer assumes all risks of loss due to operation and use of the equipment. Customer will provide "all risk" property insurance for rented equipment.

Customer shall pay Rain For Rent additional expenses caused by unforeseen or changing conditions, including, but not limited to, soil, underground conditions, rock formations, environmental conditions, weather events, regulations or restrictions, hard pan, boulders, cesspools, gas lines, water lines, drain pipes, underground electrical conduits or other above ground or underground obstructions.

All equipment rented or used products sold are provided "AS IS, WHERE IS" in their present condition. Rain for Rent makes no warranties, expressed or implied of any kind whatsoever with respect to the equipment or products. Customer agrees that customer is renting equipment or purchasing used products based on their judgment and evaluation, without reliance upon any statements of representations by Rain for Rent, and that Rain for Rent is not responsible for any defects in their operation or for any repairs, parts or services, unless otherwise noted.

All new products sold are provided without warranty beyond the terms of such warranty offered by the manufacturer, if any. Customer must comply with all original manufacturer's terms and conditions for any warranty claims that may arise. Neither Rain for Rent nor the manufacturer warranties the product if it has failed due to corrosion, misuse or damage; (2) it has been altered, repaired or modified in any way that would adversely affect its operation; or (3) it was installed or operated other than in accordance with manufacturer's operating instructions. Products supplied by Rain for Rent are warranted to be free from any defect in workmanship and material under conditions of normal use and service. Rain for Rent's obligation under this warranty is limited to replacing or repairing at the designated manufacturer's or Rain for Rent facility any part or parts returned to it with transportation charges prepaid, which Rain for Rent determines in its sole discretion to be defective.

This Quotation excludes any additional costs to Rain for Rent associated with Owner Controlled Insurance (OCIP) or WRAP insurance programs that will be added to Rain For Rent's prices.

De-watering, Roll-off, Vacuum boxes and similar equipment are not liquid tight. Rentee accepts full responsibility for all losses, damages and costs caused by or arising out of spills, leakage or discharge from this equipment. Rain for Rent will not be held liable for any structural or soils subsidence.

This Quotation is valid for 30 days and is subject to credit approval.

Rain for Rent will take every effort to protect our customers and employees. Due to the current pandemic, all quoted equipment and services are subject to delay, change, or unilateral cancelation by Rain for Rent. Please be assured every effort will be made to execute the quote as written.

The customer is responsible to inform Rain for Rent of any jobsite hazards, precautions, or entry requirements relating to the Corona Virus prior to Rain for Rent personnel going onsite to perform work or deliver equipment. This includes informing Rain for Rent if anyone at the jobsite has tested positive and provide a list of actions taken to protect Rain for Rent personnel.

## RENTAL PROTECTION PLAN PROGRAM AGREEMENT

**If you elect to maintain All Risk Property Insurance coverage, and the certificate of insurance You provide to Rain for Rent to evidence Your insurance coverage expires or is cancelled for any reason, You agree Rain for Rent may charge RPP for Your rentals until such time as You provide an acceptable and valid certificate of insurance to Rain for Rent.**

This Rental Protection Plan Program Agreement (this "RPP Agreement") is entered into between the undersigned Rentor and Rentee in relation to the Master Rental and Sales Agreement (MRSA) between Rentor and Rentee. If Rentee has checked or initialed, as applicable, the Rental Protection Plan Program (the "RPP Program") box on the quote, then Rentee has opted-in to the RPP Program and this RPP Agreement shall supplement the MRSA whether or not executed by Rentee. Rentee understands and agrees that the RPP Program is not insurance and that the RPP Program provides only limited coverage, as described below.

1. Cost; Deductible; Maximum Coverage; Rentee shall pay a fee equal to 14 percent (14%) of the rental charge for each covered item, which fee shall be listed on each invoice during which period Rentee has opted to participate in the RPP Program. In the event of a Covered Occurrence, as defined below, Rentee shall further be responsible for the lesser of \$500 or 10 percent (10%) of the total loss, as a deductible. The maximum coverage available under the RPP Program is \$150,000 per Covered Occurrence, whether or not there is more than one piece of equipment involved in the occurrence.

2. Coverage; The RPP Program provides coverage only for losses involving Covered Equipment, as defined below, in the following instances: fire that was not caused by Rentee's gross negligence or willful misconduct; theft for which a police report was filed, and that occurred despite Rentee's reasonable precautions to protect and secure the covered equipment; and vandalism for which a police report was filed (individually, "Covered Occurrence," and collectively, "Covered Occurrence"). The RPP Program provides coverage only for the following types of equipment: pumps, electric submersible pumps, tanks, generators, light towers, filtration, boxes, heaters, spillguards, safety products, sprinklers, hoses, pipe, valves and fittings ("Covered Equipment"). Coverage does not extend to any equipment not owned by Rentor such as re-rented equipment.

3. Exclusions; The RPP program does not cover any equipment or event of loss that is not specifically described in Section 2. Without limiting the foregoing, the RPP Program does not provide coverage for the following: misuse of equipment; willful abuse of equipment; failure to maintain equipment; failure to secure items from theft (including but not limited to failing to store items in a fenced, locked area or failing to maintain personnel on site); damage or theft while in transit to or from a jobsite; corrosion from any source; any damage caused by named storm events; any instance that occurs while the account is not in good standing, such as a default as defined in the MRSA or upon written notice of non-payment; and any occurrence not reported to Rentor within 24 hours after the occurrence. The RPP program does not provide coverage for: electronic equipment (controls, instrumentation, and wiring), flow meters, water meters, wheel wash systems & accessories, Freezesentry items, or tires.

4. Claims; All claims must be submitted within 24 hours of the Covered Occurrence. Rentor's mechanic will inspect the equipment following any claim. The mechanic's findings as to the cause of the damage and cost of repair will be final. In the event of a theft or vandalism, Rentee must also provide supporting evidence that the site was secured at the time of loss.

# High Head Pump

HH125c

## Overview:

The 6" suction x 4" discharge self-priming centrifugal HH125c high head pump provides up to a maximum of 1,525 gallons per minute pumping and up to 355 feet of head. This pump is usually mounted on a trailer and features the standard PowerPrime Clean Prime Venturi priming system which allows it to run continuously, unattended and even run dry.

## Features:

- Suction lift to 28 feet
- Continuous self-priming
- Runs dry unattended
- 12-volt auto start electric control panel
- Pedestal-mounted
- Flex coupled to diesel engine
- 24-hour capacity fuel tank
- Compressor fitted to operate air-injector priming system
- ASTM A48 Class 30 gray iron volute
- Enclosed 2 vane non-clog impeller and replaceable wear rings

## Specs:

* Maximum Flow	1,525 GPM
* Maximum Head	355 feet <i>145 psi</i>
Pump Size	6" x 4"
Maximum Solids Handling	3 inches
Dry weight	5,440 lbs.
Footprint: Trailer mounted model	135" x 62"
Fuel tank	190 gallon
Fuel consumption	6.7 gph @ 2,100 RPM



## Accessories:

- Spillguard
- Suction and Discharge Hoses
- Fuel Nurse Tank
- VFD for electric driven models



PUMPS • TANKS • FILTRATION • PIPE • SPILLGUARDS

Rain for Rent is a registered trademark of Western Oilfields Supply Company. Features and specifications are subject to change without notice.

**Liquid Ingenuity**  
800-742-7246  
rainforrent.com



# Rain For Rent

CURVE: 01-0133-02-26

PUMP : HH-125C

IMPELLER & WEAR RINGS CAST IRON

ALL INFORMATION CONTAINED IN OR DISCLOSED BY THIS DOCUMENT IS CONSIDERED CONFIDENTIAL AND PROPRIETARY BY RAIN FOR RENT. ALL DISCLOSURES OF DESIGN INFORMATION AND REPRODUCTION OF THIS DOCUMENT AND ALL SALES RIGHTS ARE EXCLUSIVELY RESERVED BY AND TO RAIN FOR RENT AND COMMUNICATION OF THIS INFORMATION TO OTHERS IS PROHIBITED WITHOUT THE PRIOR WRITTEN CONSENT OF RAIN FOR RENT.

SUCTION 6"

DISCHARGE 4"

MAX. SPHERE 3"

IMPELLER 2 VANE

IMPELLER 14.0"

IMPELLER & WEAR RINGS CAST IRON

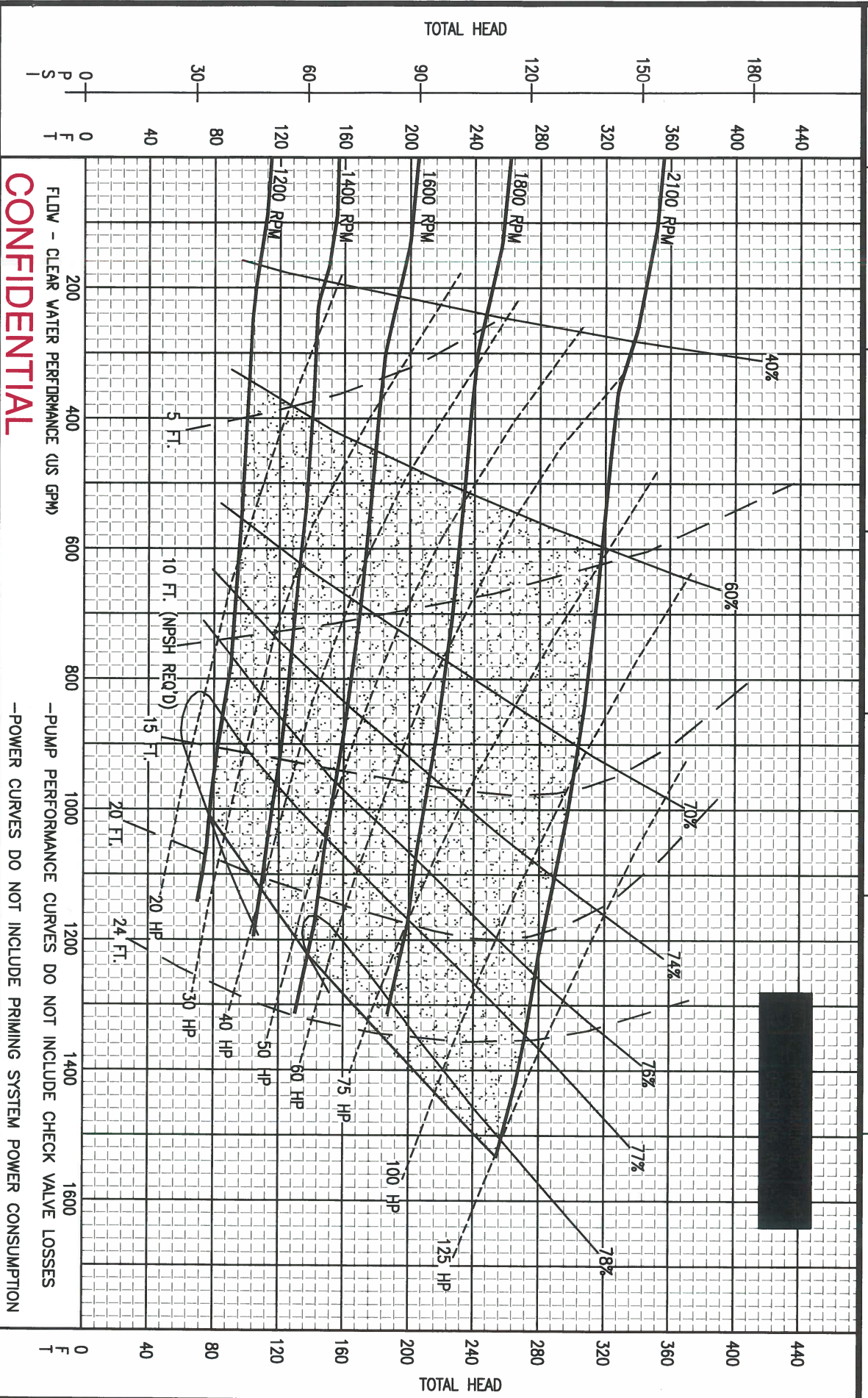

FLD.V - CLEAR WATER PERFORMANCE (US GPM)

**CONFIDENTIAL**

-PUMP PERFORMANCE CURVES DO NOT INCLUDE CHECK VALVE LOSSES  
-POWER CURVES DO NOT INCLUDE PRIMING SYSTEM POWER CONSUMPTION

**TRABUCO CANYON WATER DISTRICT  
REGULAR BOARD MEETING | JUNE 16, 2021**

**ACTION CALENDAR**

**LEGISLATIVE MATTERS**

**ITEM 17: DISCUSSION AND ACTION CONCERNING CALIFORNIA SPECIAL DISTRICT'S ASSOCIATION (CSDA) 2021 BOARD OF DIRECTORS ELECTION – SOUTHERN NETWORK, SEAT A**

---

Trabuco Canyon Water District (TCWD) is a member of the California Special Districts Association (CSDA). CSDA is comprised of six (6) networks with three seats on the Board and the candidates are either a board member or management-level employee of a member district located in your Network. Each Regular Member (district) in good standing shall be entitled to vote for one (1) person to represent its Network in Seat A. The respective candidate statements for the following candidates are included for consideration:

- Jo MacKenzie – Vista Irrigation District, Director
- Jan Bissell – Valley-Wide Recreation & Park District, Director
- Kelly Gregg – Hesperia Recreation & Park District, Director
- Rickey Manbahal – West Valley Water District, Interim General Manager
- Jo-Anne Martin – Placentia Library District, Director
- Paulina Martinez-Perez – South Bay Irrigation District, Director
- Rachel Mason – Fallbrook Regional Health District, Chief Executive Officer
- David E. Raley – San Bernardino Valley Water Conservation District, Director
- John Skerbelis – Rubidoux Community Services District, Director

CSDA has issued an online ballot for the Southern Network, Seat A Board of Directors election. Completed ballots must be received at the CSDA by **5:00 pm on July 16, 2021**.

**RECOMMENDED ACTION(S):**

1. *Review and discuss the candidates running for the CSDA Board of Directors, Southern Network, Seat A.*
2. *Authorize District staff to cast the District's election ballot on behalf of Director Acosta.*

**EXHIBIT(S):**

1. CSDA 2021 Board of Directors Election Sample Ballot
2. Candidate Statements

**CONTACTS (staff responsible): PALUDI/PEREA**



Home

How It Works

Logout Michael Perea

**CSDA Board of Directors Election Ballot - Term 2022-2024; Seat A - Southern Network**

**Please vote for your choice**

Choose one of the following candidates:

- Jo MacKenzie\*
- Jan Bissell
- Kelly Gregg
- Rickey Manbahal
- Jo-Anne Martin
- Paulina Martinez-Perez
- Rachel Mason
- David E. Raley
- John Skerbelis

\*Incumbent

Jo MacKenzie\* [\[view details\]](#)

Jan Bissell [\[view details\]](#)

Kelly Gregg [\[view details\]](#)

Rickey Manbahal [\[view details\]](#)

Jo-Anne Martin [\[view details\]](#)

Paulina Martinez-Perez [\[view details\]](#)

Rachel Mason [\[view details\]](#)

David E. Raley [\[view details\]](#)

John Skerbelis [\[view details\]](#)

Continue

Cancel



**California Special  
Districts Association**  
*Districts Stronger Together*

## 2021 CSDA BOARD CANDIDATE INFORMATION SHEET

The following information **MUST** accompany your nomination form and Resolution/minute order:

**Name:** Jo MacKenzie

**District/Company:** Vista Irrigation District, *CSDA District of Distinction, Platinum Level*

**Title:** Director

**Elected/Appointed/Staff:** Elected

**Length of Service with District:** 29 years

**1. Do you have current involvement with CSDA (such as committees, events, workshops, conferences, Governance Academy, etc.):**

- CSDA Board of Directors, President 2011, Vice President 2010, Treasurer 2008-2009
- CSDA Legislative Advocate of the Year 2010
- Graduate of CSDA Governance Academy
- CSDA Finance Corporation Board of Directors, 2007-present; President 2012, 2013, 2015- present
- Special District Leadership Foundation Board of Directors, Treasurer 2014-present
- Fiscal and Audit Committees; Membership Committee 2011- present; Chair 2020-2021
- Legislative Committee 2004-present; Chair, 2006-2010 and 2012
- CSDA San Diego Chapter, Board of Directors, 1993-present; President 1998-2000
- Attend all Annual Conferences and Legislative Days

**2. Have you ever been associated with any other state-wide associations (CSAC, ACWA, League, etc.):**

- ACWA: Past Board Director; Local Government, Chair 2014-2015 and Membership Committee
- ACWA Region 10 Board of Directors, Vice Chair, Alternate Chair, Director 1997-2010
- The California Association of Local Agency Formation Commissions (CALAFCO), Board Member and Legislative Committee member, 2017 - present
- Special District Official of the Year by PublicCEO 2011

**3. List local government involvement (such as LAFCO, Association of Governments, etc.):**

- San Diego LAFCO, 1994-present, Commissioner 7 years, Chair 2018-2019; Alternate 5 years; Special District Advisory Committee 14 years, Chair 2005 -2009
- City of San Marcos Planning and Traffic Commissions
- Personally initiated the City of San Marcos Budget Review Committee in 1980, Chair 1996-2006

**4. List civic organization involvement:**

- San Marcos Chamber of Commerce, Lifetime Ambassador
- Graduate Leadership 2000, Cal State San Marcos
- Community Development Associates, Treasurer
- Soroptimist International

**\*\*Candidate Statement-**Although it is not required, each candidate is requested to submit a candidate statement of no more than 300 words in length. **Any statements received in the CSDA office after March 29, 2021 will not be included with the ballot mailing.**



**California Special  
Districts Association**  
*Districts Stronger Together*

## 2021 CSDA BOARD CANDIDATE INFORMATION SHEET

The following information **MUST** accompany your nomination form and Resolution/minute order:

Name: Jan Bissell

District/Company: Valley-Wide Recreation and Park District

Title: Vice President

Elected/Appointed/Staff: Elected

Length of Service with District: 14 years (1999 - 2010, 2018 - to present day)

1. Do you have current involvement with CSDA (such as committees, events, workshops, conferences, Governance Academy, etc.):

Attendee of CSDA Conference

2. Have you ever been associated with any other state-wide associations (CSAC, ACWA, League, etc.):

California Parks and Recreation Society (CPRS), California Association of Recreation Park Districts (CARPD), California Interscholastic Federation (CIF).

3. List local government involvement (such as LAFCo, Association of Governments, etc.):

Valley-Wide Recreation and Park District (VWRPD)

4. List civic organization involvement:

First Baptist School Board, USA Pickleball Association (USAPA), Friends of Valley-Wide Foundation (FOVWF), Local Pony Baseball and Softball Associations.

**\*\*Candidate Statement** – Although it is not required, each candidate is requested to submit a candidate statement of no more than 300 words in length. **Any statements received in the CSDA office after March 29, 2021 will not be included with the ballot.**



**2021 CSDA BOARD CANDIDATE INFORMATION SHEET**

The following information **MUST** accompany your nomination form and Resolution/minute order:

Name: Kelly J Gregg

District/Company: Hesperia Recreation and Park District

Title: Director

Elected/Appointed/Staff: Elected

Length of Service with District: 9 years

1. Do you have current involvement with CSDA (such as committees, events, workshops, conferences, Governance Academy, etc.):

Have attended several CSDA conferences and workshops.

2. Have you ever been associated with any other state-wide associations (CSAC, ACWA, League, etc.):

N/A

3. List local government involvement (such as LAFCo, Association of Governments, etc.):

Current chair for City of Hesperia Safety committee.

4. List civic organization involvement:

Member of Elks lodge #2646. Have assisted in many community events.

**\*\*Candidate Statement** – Although it is not required, each candidate is requested to submit a candidate statement of no more than 300 words in length. **Any statements received in the CSDA office after March 29, 2021 will not be included with the ballot.**



**2021 CSDA BOARD CANDIDATE INFORMATION SHEET**

The following information **MUST** accompany your nomination form and Resolution/minute order:

Name: Shamindra "Rickey" Manbahal, MPA

District/Company: West Valley Water District

Title: Interim General Manager, Chief Financial & Administrative Officer

Elected/Appointed/Staff: WVWD Board & Public Affairs Manager Naseem Farooqi

Length of Service with District: 1.7 years

1. Do you have current involvement with CSDA (such as committees, events, workshops, conferences, Governance Academy, etc.):

Participated in several training Transparency Certificate of Excellence, Leadership Academy and General Manager Training, attended conferences and is registered for 2021 conference.

2. Have you ever been associated with any other state-wide associations (CSAC, ACWA, League, etc.):

ACWA, GFOA, CMTA, CSMFO, League of California Cities

3. List local government involvement (such as LAFCo, Association of Governments, etc.):

GFOA and LAFCO

4. List civic organization involvement:

Various Chamber of Commerce activities, Various non-profit participation  
Jewish Vocational Service, High Road Training Program

**\*\*Candidate Statement** – Although it is not required, each candidate is requested to submit a candidate statement of no more than 300 words in length. **Any statements received in the CSDA office after March 29, 2021 will not be included with the ballot.**



**California Special  
Districts Association**  
*Districts Stronger Together*

## 2021 CSDA BOARD CANDIDATE INFORMATION SHEET

The following information **MUST** accompany your nomination form and Resolution/minute order:

Name: Jo-Anne Martin

District/Company: Placentia Library District

Title: Board President

Elected/Appointed/Staff: Elected

Length of Service with District: \_\_\_\_\_

1. Do you have current involvement with CSDA (such as committees, events, workshops, conferences, Governance Academy, etc.):

I routinely attend the CSDA annual conference, as well as the Legislative Days. I have completed  
multiple CSDA webinars and training sessions. I also completed CSDA's Board Secretary Workshop.

2. Have you ever been associated with any other state-wide associations (CSAC, ACWA, League, etc.):

I am a member of the League of Women Voters and the California/Nevada League  
of Credit Unions.

3. List local government involvement (such as LAFCo, Association of Governments, etc.):

None.

4. List civic organization involvement:

I currently serve as an Associate Director on Financial Partners Credit Union's Board of Directors, as the Secretary for Alta Vista's Women's Golf Association, an Elder of the Placentia Presbyterian Church and as a literacy volunteer for the Placentia Library District. I am also a past chair and board member of the Homeless Intervention Shelter.

**\*\*Candidate Statement** – Although it is not required, each candidate is requested to submit a candidate statement of no more than 300 words in length. **Any statements received in the CSDA office after March 29, 2021 will not be included with the ballot.**



**2021 CSDA BOARD CANDIDATE INFORMATION SHEET**

The following information **MUST** accompany your nomination form and Resolution/minute order:

Name: Paulina Martinez-Perez

District/Company: South Bay Irrigation District

Title: Director- Division 2

Elected/Appointed/Staff: Elected

Length of Service with District: 4 year term- 2020-2024

1. Do you have current involvement with CSDA (such as committees, events, workshops, conferences, Governance Academy, etc.):

Workshops: Getting Oriented: The Critical Nature of Communications in the Public Age

2. Have you ever been associated with any other state-wide associations (CSAC, ACWA, League, etc.):

Currently the delegate to ACWA representing South Bay Irrigation District, and an alternate representing Sweetwater Authority.

3. List local government involvement (such as LAFCo, Association of Governments, etc.):

N/A

4. List civic organization involvement:

Public school teacher at a heavily civically involved TK-12 systemt that promotes

social justice and civic engagement with all students. Have also participated in fellowshi

**\*\*Candidate Statement** – Although it is not required, each candidate is requested to submit a candidate statement of no more than 300 words in length. **Any statements received in the CSDA office after March 29, 2021 will not be included with the ballot.**



**California Special  
Districts Association**  
*Districts Stronger Together*

## 2021 BOARD OF DIRECTORS NOMINATION FORM

**Name of Candidate:** Rachel Mason

**District:** Fallbrook Regional Health District

**Mailing Address:** 138 S. Brandon Rd., Fallbrook, CA 92028

**Network:** Southern Network (see map)

**Telephone:** Office:760.731.9187 or Cell: 909.838.8071  
(PLEASE BE SURE THE PHONE NUMBER IS ONE WHERE WE CAN REACH THE CANDIDATE)

**Fax:** 760.731.9131

**E-mail:** rmason@fallbrookhealth.org

**Nominated by (optional):** Jennifer Jeffries, FRHD Board Treasurer

**Return this form and a Board resolution/minute action supporting the candidate and Candidate Information Sheet by mail or email to:**

CSDA  
Attn: Amber Phelen  
1112 I Street, Suite 200  
Sacramento, CA 95814  
(877) 924-2732

amberp@csda.net

***DEADLINE FOR RECEIVING NOMINATIONS – March 29, 2021***



**California Special  
Districts Association**  
*Districts Stronger Together*

## 2021 CSDA BOARD CANDIDATE INFORMATION SHEET

The following information **MUST** accompany your nomination form and Resolution/minute order:

Name: David E. Raley

District/Company: San Bernardino Valley Water Conservation District

Title: Director

Elected/Appointed/Staff: Elected

Length of Service with District: 11 years

1. Do you have current involvement with CSDA (such as committees, events, workshops, conferences, Governance Academy, etc.):

I have taken Governance Training through CSDA.

2. Have you ever been associated with any other state-wide associations (CSAC, ACWA, League, etc.):

Our District is currently a member of ACWA.

3. List local government involvement (such as LAFCo, Association of Governments, etc.):

Please see attached statement.

4. List civic organization involvement:

Please see attached statement.

**\*\*Candidate Statement** – Although it is not required, each candidate is requested to submit a candidate statement of no more than 300 words in length. **Any statements received in the CSDA office after March 29, 2021 will not be included with the ballot.**



**California Special  
Districts Association**  
*Districts Stronger Together*

## 2021 CSDA BOARD CANDIDATE INFORMATION SHEET

The following information **MUST** accompany your nomination form and Resolution/minute order:

Name: John Skerbelis

District/Company: Rubidoux Community Services District

Title: Director

Elected/Appointed/Staff: Elected

Length of Service with District: 8 years

1. Do you have current involvement with CSDA (such as committees, events, workshops, conferences, Governance Academy, etc.):

None

2. Have you ever been associated with any other state-wide associations (CSAC, ACWA, League, etc.):

None

3. List local government involvement (such as LAFCo, Association of Governments, etc.):

Riverside County Solid Waste Advisory Committee

Rubidoux Community Services District - Board of Directors

4. List civic organization involvement:

Past involvement with Riverside County Dept of Environmental Health on Community clean ups

**\*\*Candidate Statement** – Although it is not required, each candidate is requested to submit a candidate statement of no more than 300 words in length. **Any statements received in the CSDA office after March 29, 2021 will not be included with the ballot.**

**TRABUCO CANYON WATER DISTRICT  
REGULAR BOARD MEETING | JUNE 16, 2021**

**ACTION CALENDAR**

**LEGISLATIVE AND OTHER MATTERS**

**ITEM 18: LOCAL GOVERNMENTAL AND LEGISLATIVE INFORMATIONAL MATTER(S)**

---

**RECOMMENDED ACTION(S):**

*Review and discuss local government and legislative informational matter(s) and take action(s) as deemed appropriate.*

**EXHIBIT(S):**

None

**CONTACTS (staff responsible): PALUDI/PEREA**

**TRABUCO CANYON WATER DISTRICT  
REGULAR BOARD MEETING | JUNE 16, 2021**

**CLOSED SESSION**

**ITEM 19: REPORT OF ACTION(S) TAKEN IN CLOSED SESSION**

---

**RECOMMENDED ACTION(S):**

*Receive information at the time of the Board meeting and take action(s) as deemed appropriate.*

**CONTACTS (staff responsible): PALUDI/PEREA**